



# SERVICE MANUAL

**5.0KW BCG-60Hz / 4.2 KW BCG-50Hz**

**5.0KW BCGA-60Hz / 4.2KW BCGA-50Hz**

**7.0KW BCGC-60Hz / 5.9KW BCGC-50Hz**

**7.0KW BCGD-60Hz / 5.9KW BCGD-50Hz**

**GASOLINE GENERATORS Single Phase**

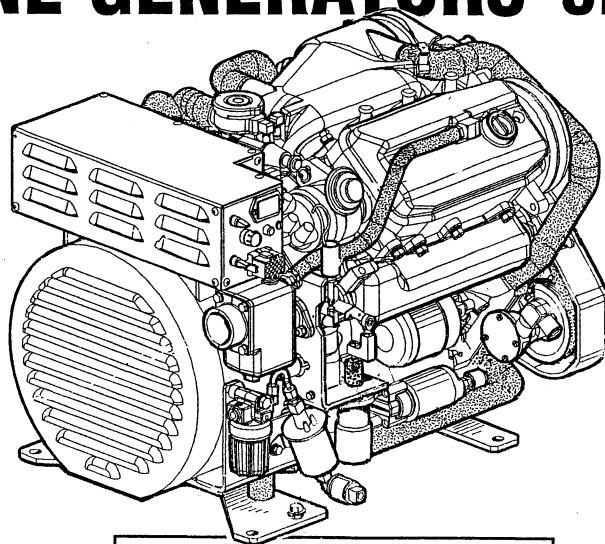

**PUBLICATION #052020  
REV#2 SEPTEMBER 2014**



WESTERBEKE CORPORATION • 150 JOHN HANCOCK ROAD  
MYLES STANDISH INDUSTRIAL PARK • TAUNTON MA 02780  
WEB SITE: [WWW.WESTERBEKE.COM](http://WWW.WESTERBEKE.COM)

**⚠ WARNING**

**Exhaust gasses contain Carbon Monoxide, an odorless and colorless gas. Carbon Monoxide is poisonous and can cause unconsciousness and death. Symptoms of Carbon Monoxide exposure can include:**

- **Dizziness**
- **Throbbing in Temples**
- **Nausea**
- **Muscular Twitching**
- **Headache**
- **Vomiting**
- **Weakness and Sleepiness**
- **Inability to Think Coherently**

**IF YOU OR ANYONE ELSE EXPERIENCE ANY OF THESE SYMPTOMS, GET OUT INTO THE FRESH AIR IMMEDIATELY. If symptoms persist, seek medical attention. Shut down the unit and do not restart until it has been inspected and repaired.**



**A WARNING DECAL is provided by WESTERBEKE and should be fixed to a bulkhead near your engine or generator. WESTERBEKE also recommends installing CARBON MONOXIDE DETECTORS in the living/sleeping quarters of your vessel. They are inexpensive and easily obtainable at your local marine store.**

**CALIFORNIA  
PROPOSITION 65 WARNING**

**Marine diesel and gasoline engine exhaust and some of its constituents are known to the State of California to cause cancer, birth defects, and other reproductive harm.**

# SAFETY INSTRUCTIONS

## INTRODUCTION

Read this safety manual carefully. Most accidents are caused by failure to follow fundamental rules and precautions. Know when dangerous conditions exist and take the necessary precautions to protect yourself, your personnel, and your machinery.

The following safety instructions are in compliance with the American Boat and Yacht Council (ABYC) standards.

## PREVENT ELECTRIC SHOCK

**⚠ WARNING: Do not touch AC electrical connections while engine is running. Lethal voltage is present at these connections!**

- Do not operate this machinery without electrical enclosures and covers in place.
- Shut off electrical power before accessing electrical equipment.
- Use insulated mats whenever working on electrical equipment.
- Make sure your clothing and skin are dry, not damp (particularly shoes) when handling electrical equipment.
- Remove wristwatch and all jewelry when working on electrical equipment.

## PREVENT BURNS — HOT ENGINE

**⚠ WARNING: Do not touch hot engine parts or exhaust system components. A running engine gets very hot!**

- Monitor engine antifreeze coolant level at the plastic coolant recovery tank and periodically at the filler cap location on the water jacketed exhaust manifold, but only when the engine is COLD.

**⚠ WARNING: Steam can cause injury or death!**

- In case of an engine overheat, allow the engine to cool before touching the engine or checking the coolant.

## PREVENT BURNS — FIRE

**⚠ WARNING: Fire can cause injury or death!**

- Prevent flash fires. Do not smoke or permit flames or sparks to occur near the carburetor, fuel line, filter, fuel pump, or other potential sources of spilled fuel or fuel vapors. Use a suitable container to catch all fuel when removing the fuel line, carburetor, fuel filters, or other fuel system components.
- Do not operate with the air cleaner/silencer or flame arrester screen removed. Backfire can cause severe injury or death.
- Do not smoke or permit flames or sparks to occur near the fuel system. Keep the compartment and the engine/generator clean and free of debris to minimize the chances of fire. Wipe up all spilled fuel and engine oil.

## PREVENT BURNS — EXPLOSION

**⚠ WARNING: Explosions from fuel vapors can cause injury or death!**

- Follow re-fueling safety instructions. Keep the vessel's hatches closed when fueling. Open and ventilate cabin after fueling. Check below for fumes/vapor before running the blower. Run the engine compartment blower prior to starting, follow the recommendation of the vessel builder.
- All fuel vapors are highly explosive. Use extreme care when handling and storing fuels. Store fuel in a well-ventilated area away from spark-producing equipment and out of the reach of children.
- Do not fill the fuel tank(s) while the engine is running.
- Shut off the fuel service valve at the engine when servicing the fuel system. Take care in catching any fuel that might spill. DO NOT allow any smoking, open flames, or other sources of fire near the fuel system or engine when servicing. Ensure proper ventilation exists when servicing the fuel system.
- Do not alter or modify the fuel system.
- Be sure all fuel supplies have a positive shutoff valve.
- Be certain fuel line fittings are adequately tightened and free of leaks.
- Make sure a fire extinguisher is installed nearby and is properly maintained. Be familiar with its proper use. Extinguishers rated ABC by the NFPA are appropriate for all applications encountered in this environment.

# SAFETY INSTRUCTIONS

## ACCIDENTAL STARTING

 **WARNING:** *Accidental starting can cause injury or death!*

- Disconnect the battery cables before servicing the engine/generator. Remove the negative lead first and reconnect it last.
- Make certain all personnel are clear of the engine before starting.
- Make certain all covers, guards, and hatches are re-installed before starting the engine.

## BATTERY EXPLOSION

 **WARNING:** *Battery explosion can cause injury or death!*

- Do not smoke or allow an open flame near the battery being serviced. Lead acid batteries emit hydrogen, a highly explosive gas, which can be ignited by electrical arcing or by lit tobacco products. Shut off all electrical equipment in the vicinity to prevent electrical arcing during servicing.
- Never connect the negative (-) battery cable to the positive (+) connection terminal of the starter solenoid. Do not test the battery condition by shorting the terminals together. Sparks could ignite battery gases or fuel vapors. Ventilate any compartment containing batteries to prevent accumulation of explosive gases. To avoid sparks, do not disturb the battery charger connections while the battery is being charged.
- Avoid contacting the terminals with tools, etc., to prevent burns or sparks that could cause an explosion. Remove wristwatch, rings, and any other jewelry before handling the battery.
- Always turn the battery charger off before disconnecting the battery connections. Remove the negative lead first and reconnect it last when servicing the battery.

## BATTERY ACID

 **WARNING:** *Sulfuric acid in batteries can cause severe injury or death!*

- When servicing the battery or checking the electrolyte level, wear rubber gloves, a rubber apron, and eye protection. Batteries contain sulfuric acid which is destructive. If it comes in contact with your skin, wash it off at once with water. Acid may splash on the skin or into the eyes inadvertently when removing electrolyte caps.

## TOXIC EXHAUST GASES

 **WARNING:** *Carbon monoxide (CO) is a deadly gas!*

- Ensure that the exhaust system is adequate to expel gases discharged from the engine. Check the exhaust system regularly for leaks and make sure the exhaust manifold/water-injected elbow is securely attached.
- Be sure the unit and its surroundings are well ventilated. Run blowers when running the generator set or engine.
- Do not run the generator set or engine unless the boat is equipped with a functioning marine carbon monoxide detector that complies with ABYC A-24. Consult your boat builder or dealer for installation of approved detectors.
- For additional information, refer to ABYC TH-22 (educational information on Carbon Monoxide).

 **WARNING:** *Carbon monoxide (CO) is an invisible odorless gas. Inhalation produces flu-like symptoms, nausea or death!*

- Do not use copper tubing in exhaust systems. Exhaust sulfur causes rapid deterioration of copper tubing resulting in exhaust/water leakage.
- Do not install exhaust outlet where exhaust can be drawn through portholes, vents, or air conditioners. If the engine exhaust discharge outlet is near the waterline, water could enter the exhaust discharge outlet and close or restrict the flow of exhaust. Avoid overloading the craft.
- Carbon monoxide gas is present in exhaust fumes. Some of the symptoms or signs of carbon monoxide inhalation or poisoning are:

Vomiting	Muscular twitching
Dizziness	Intense headache
Throbbing in temples	Weakness and sleepiness

## AVOID MOVING PARTS

 **WARNING:** *Rotating parts can cause injury or death!*

- Do not service the engine while it is running. If a situation arises in which it is absolutely necessary to make operating adjustments, use extreme care to avoid touching moving parts and hot exhaust system components.

# SAFETY INSTRUCTIONS

- Do not wear loose clothing or jewelry when servicing equipment; tie back long hair and avoid wearing loose jackets, shirts, sleeves, rings, necklaces or bracelets that could be caught in moving parts.
- Make sure all attaching hardware is properly tightened. Keep protective shields and guards in their respective places at all times.
- Do not check fluid levels or the drive belt's tension while the engine is operating.
- Do not allow any swimming or activity around or near the exhaust discharge opening for the generator while the generator is operating. Carbon Monoxide poisoning or death can occur.

## HAZARDOUS NOISE

**⚠ WARNING: High noise levels can cause hearing loss!**

- Never operate an engine without its muffler installed.
- Do not run the engine with the air intake (silencer) or flame arrester removed.
- Do not run engines for long periods with their enclosures open (when installed).

**⚠ WARNING: Do not work on machinery when you are mentally or physically incapacitated by fatigue!**

## OPERATORS MANUAL

Many of the preceding safety tips and warnings are repeated in your Operators Manual along with other cautions and notes to highlight critical information. Read your manual carefully, maintain your equipment, and follow all safety procedures.

## GASOLINE ENGINE AND GENERATOR INSTALLATIONS

Preparations to install a gasoline engine or generator should begin with a thorough examination of the American Boat and Yacht Council's (ABYC) standards. These standards are from a combination of sources including the USCG and the NFPA.

Sections of the ABYC standards of particular interest are:

- H-2 Ventilation for Boats using Gasoline
- H-24 Gasoline Fuel Systems
- P-1 Installation of Exhaust Systems  
for Propulsion and Auxiliary Engines
- P-4 Marine Inboard Engines and Transmissions
- E-11 AC and DC Electrical Systems on Boats

All installations must comply with the Federal Code of Regulations (FCR).

[www.abycinc.org](http://www.abycinc.org)

## ABYC, NFPA AND USCG PUBLICATIONS FOR INSTALLING ENGINES AND GENERATORS

Read the following ABYC, NFPA and USCG publications for safety codes and standards. Follow their recommendations when installing your engine.

**ABYC** (American Boat and Yacht Council)  
"Standards and Technical Information Reports for Small Craft"

Order from:

ABYC  
613 Third Street, Suite 10  
Annapolis, MD 21403

[www.abycinc.org](http://www.abycinc.org)

**NFPA - No.302** (National Fire Protection Association)  
"Pleasure and Commercial Motor Craft"

Order from:

National Fire Protection Association  
Battery March Park  
Quincy, MA 02269

**USCG** (United States Coast Guard)  
"regulations are under titles CFR33 and CFR46 of the Code of Regulations"

Order from:

U.S. Government Printing Office  
Washington, D.C. 20404

## INSTALLATION

When installing WESTERBEKE engines and generators it is important that strict attention be paid to the following information:

### CODES AND REGULATIONS

Strict federal regulations, ABYC guidelines, and safety codes must be complied with when installing engines and generators in a marine environment.

### SIPHON-BREAK

For installations where the exhaust manifold/water injected exhaust elbow is close to or will be below the vessel's waterline, provisions must be made to install a siphon-break in the raw water supply hose to the exhaust elbow. This hose must be looped a minimum of 20" above the vessel's waterline. *Failure to use a siphon-break when the exhaust manifold injection port is at or below the load waterline will result in raw water damage to the engine and possible flooding of the boat.*

If you have any doubt about the position of the water-injected exhaust elbow relative to the vessel's waterline under the vessel's various operating conditions, *install a siphon-break.*

**NOTE:** *A siphon-break requires periodic inspection and cleaning to ensure proper operation. Failure to properly maintain a siphon-break can result in catastrophic engine damage. Consult the siphon-break manufacturer for proper maintenance.*

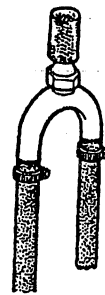

AVAILABLE FROM  
YOUR WESTERBEKE  
DEALER

SIPHON-BREAK WITH STAINLESS  
LOOP

### EXHAUST SYSTEM

The exhaust system's hose **MUST** be certified for marine use. Corrugated Marine Exhaust Hose is recommended. The use of this type of hose allows for extreme bends and turns without the need of additional fitting and clamps to accomplish these bends and turns. In this regard, a single length of corrugated exhaust hose can be used. The system **MUST** be designed to prevent the entry of water into the exhaust system under any sea conditions and at any angle of vessels heel.

**A detailed Marine Installation Manual covering gasoline and diesel, engines and generators, is supplied with each unit. A pdf is available to download from our website at [www.westerbeke.com](http://www.westerbeke.com).**

# TABLE OF CONTENTS

Parts Identification .....	2
Testing for Overhaul .....	3
Troubleshooting Chart .....	4
Generator/Engine Disassembly .....	6
Engine Assembly .....	7
Timing Belt Disassembly .....	8
Engine Disassembly (p.12-p.31) .....	12
Service Data/Standards and Limits .....	32
Engine Hardware Torques .....	33a
Special Tools - Engine .....	34
Exhaust Manifold/Heat Exchanger .....	35
Coolant Circulating Pump .....	36
Raw Water Pump .....	37
Carburetor .....	38
Distributor .....	39
Starter Motor .....	40
Wiring Diagram .....	44
Wiring Schematic .....	45
Remote Panel Wiring .....	46
Test-Safety Shutdown Switches/Relays .....	47
Test Ignition Coil/Igniter .....	49
Panel Wiring Schematic .....	50
Electronic Governor .....	51
Magnetic Pick-Up .....	52
Electronic Governor Troubleshooting .....	53
Engine Adjustments .....	54
Battery Charge Controller .....	57
Specifications 7.0Kw .....	59
Specifications 5.0Kw .....	60
Generator Information .....	61
BC Generator Testing and Troubleshooting (p.63-p.72) .....	63
Governor Wiring Diagram .....	73
Special Tools - Generator .....	74
Terminal Board Connections .....	75
Remote Oil Filter .....	75
Bolt and Nut Tightening Method .....	76
Shore Power Transfer Switch .....	77
Bolt and Nut Tightening Method .....	76
Metric Conversion Data .....	78
Index .....	81

# PARTS IDENTIFICATION

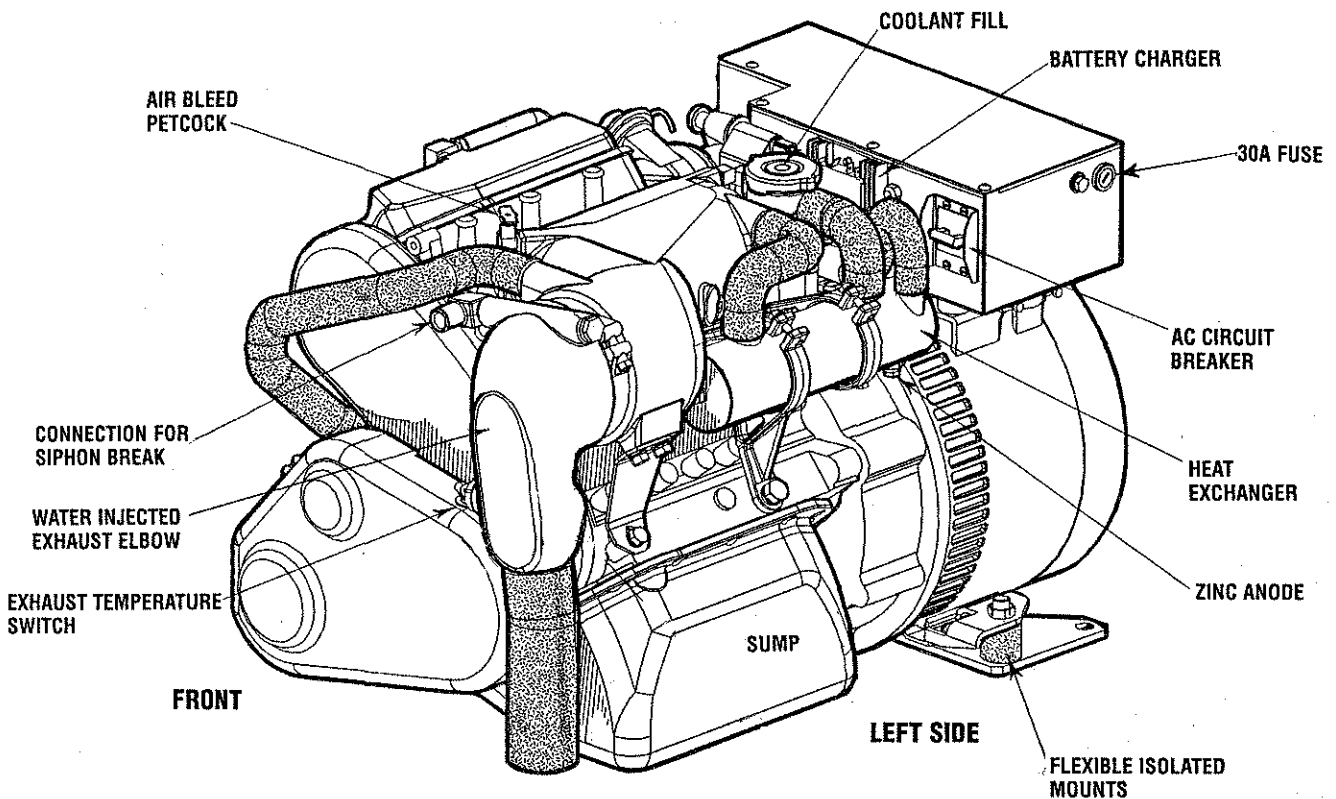
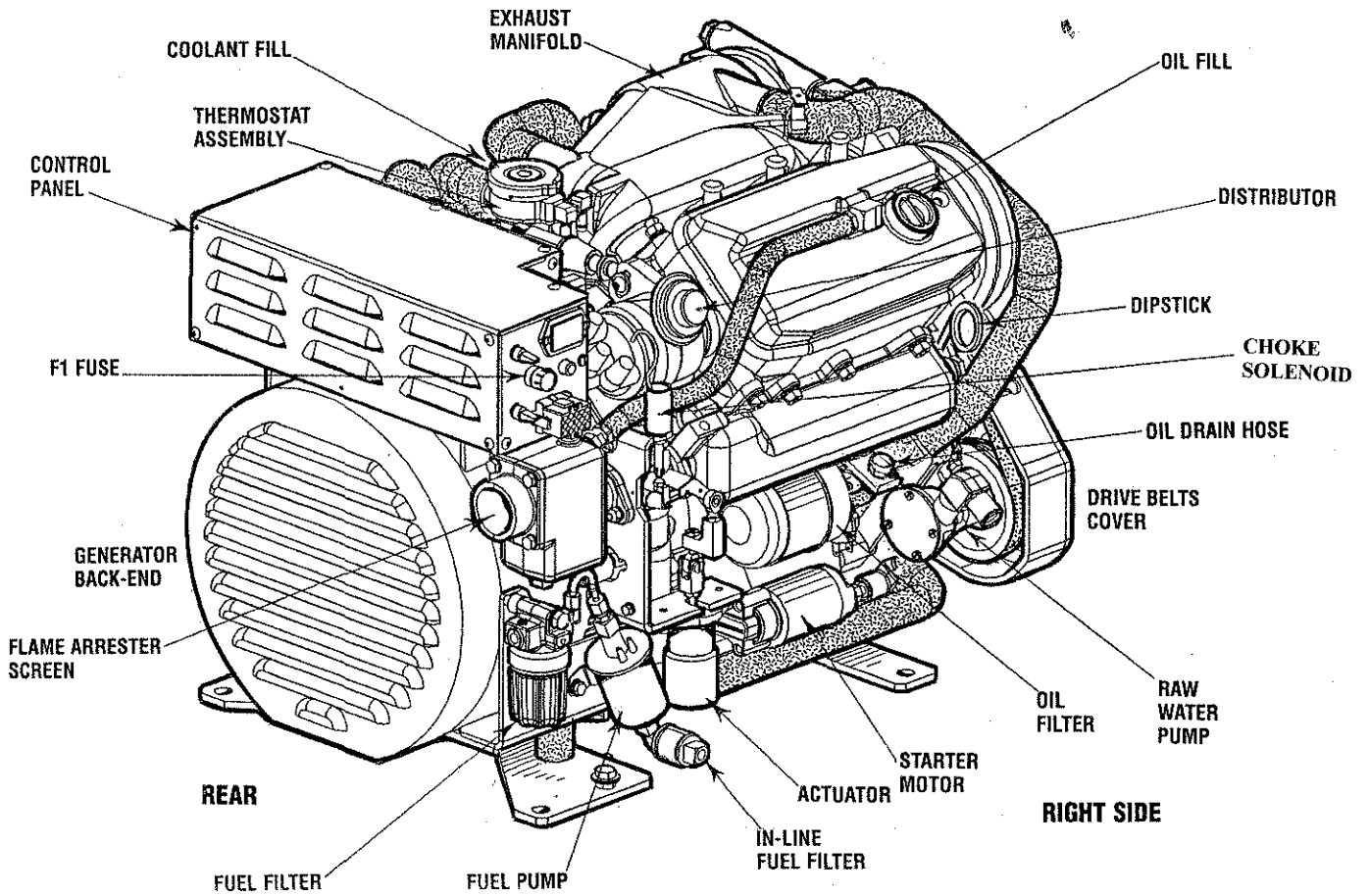



# TESTING FOR OVERHAUL

## HOW TO DETERMINE ENGINE OVERHAUL PERIOD

### Cause of Low Compression

Generally, the time at which an engine should be overhauled is determined by various conditions such as lowered engine power output, decreased compression pressure, and increased fuel and oil consumption. The lowered engine power output is not necessarily due to trouble with the engine itself, but is sometimes caused by improper oil, clogged filters or a faulty carburetor.

The decrease in compression pressure is caused by many factors. It is, therefore, necessary to determine a cause or causes on the basis of data produced by periodic inspection and maintenance. Oil analysis on a seasonal basis is a good means of monitoring engine internal wear. When caused by worn cylinders or piston rings, the following symptoms will occur:

- 1 Low engine power output
- 2 Increased fuel consumption
- 3 Increased oil consumption
- 4 Hard engine starting
- 5 Noisy engine operation

These symptoms often appear together. Symptoms 2 and 4 can result also from improper fuel regulation or a faulty carburetor. They are caused also by defective electrical devices such as the battery, starter or spark plugs. Therefore, it is desirable to judge the optimum engine overhaul time by the lowered compression pressure caused by worn cylinders and pistons plus increased oil consumption. Satisfactory combustion is obtained only under sufficient compression pressure. If an engine lacks compression pressure, incomplete combustion of fuel will take place even if other parts of the engine are operating properly. To determine the period of engine overhaul, it is important to measure the engine compression pressure regularly. At the same time, the engine speed at which the measurement of compression pressure is made should be checked because the compression pressure varies with engine rpm. The engine rpm can be measured at the front end of the crankshaft.

**NOTE:** To test engine compression see the *ENGINE ADJUSTMENT* section of this manual.

## OVERHAUL CONDITIONS

Compression pressure tends to increase a little in a new engine until piston rings and valve seats have been broken in. Thereafter, it decreases gradually with the progress of wear of these parts.

When decrease of compression pressure reaches the repair limit, the engine must be overhauled.

The engine requires overhaul when oil consumption is high, blowby evident, and compression values are at minimum or below. *Engine compression should be 178 psi (1260 Kpa) at 250 rpm. With a limit 137 psi (860 Kpa). Pressure should not differ by more than 14 psi (100 Kpa) between cylinders. See ENGINE COMPRESSION in this manual.*

## ENGINE OVERHAUL

The following sections contain detailed information relating to the major components and systems of the engine. Included are disassembly and inspection instructions for the guidance of suitable equipped and staffed marine engine service and rebuilding facilities. The necessary procedures should be undertaken only by such facilities.

Additional detailed information and specifications are provided in other sections of this manual, covering the generator, alternator, starter motor, engine adjustments, cooling pumps, etc.

## DISASSEMBLY

1. Before disassembly and cleaning, carefully check for defects which cannot be found after disassembly and cleaning.
2. Clean the engine exterior.
3. Perform disassembly in a proper order using proper tools. Keep disassembled parts in order. Apply oil when necessary. Take special care to keep the fuel system parts from intrusion of dust and dirt.

# BCG GENERATOR TROUBLESHOOTING

The following troubleshooting chart describes certain problems relating to engine service, the probable causes of these problems, and the recommendations to overcome these problems.

This chart may be of assistance in determining the need for an engine overhaul. For back-end troubleshooting, refer to the *BC GENERATOR ELECTRICAL TESTING* section in this manual.

PROBLEM	PROBABLE CAUSE	VERIFICATION/REMEDY
<b>HARD STARTING OR FAILURE TO START</b>	<ol style="list-style-type: none"> <li>1. Contaminated fuel.</li> <li>2. Timing belt.</li> <li>3. AC generator overload.</li> <li>4. Check valve at fuel supply.</li> <li>5. Defective starter.</li> <li>6. Faulty ignition.</li> <li>7. Raw water in cylinders.</li> </ol>	<ol style="list-style-type: none"> <li>1. Check system.</li> <li>2. Inspect timing belt-replace.</li> <li>3. Remove loads before starting..</li> <li>4. Repair or replace..</li> <li>5. Repair or replace starter.</li> <li>6. Check ignition system.</li> <li>7. Failure of exhaust system or syphon break. Clear cylinders. Engine may need overhaul.</li> </ol>
<b>SMOKY EXHAUST</b>	<p><b>WHITE, PURPLE OR BLUE SMOKE</b></p> <ol style="list-style-type: none"> <li>1. Excessive engine oil..</li> <li>2. Excessive rise of oil into combustion chamber.                             <ol style="list-style-type: none"> <li>a. Poor piston contact.</li> <li>b. Seized piston ring.</li> <li>c. Excessive piston-to-cylinder clearance.</li> <li>d. Worn valve stem and valve guide.</li> <li>e. Low engine oil viscosity.</li> <li>f. Excessive oil pressure.</li> <li>g. Piston rings are worn or unseated.</li> </ol> </li> <li>3. Insufficient compression.</li> </ol>	<ol style="list-style-type: none"> <li>1. Correct oil level.</li> <li>2. Engine overhaul.                             <ol style="list-style-type: none"> <li>a. Check standard.</li> <li>b. Replace or clean.</li> <li>c. Replace or correct.</li> <li>d. Replace.</li> <li>e. Replace.</li> <li>f. Correct.</li> <li>g. Engine overhaul.</li> </ol> </li> <li>3. See <i>LOW COMPRESSION; HARD STARTING</i>.</li> </ol>
	<p><b>BLACKISH OR DARK GRAY</b></p> <ol style="list-style-type: none"> <li>1. Poor compression.</li> <li>2. Improper valve clearance.</li> <li>3. Insufficient intake air (air cleaner clogged).</li> <li>4. Improper fuel.</li> </ol>	<ol style="list-style-type: none"> <li>1. See <i>LOW COMPRESSION</i>.</li> <li>2. Valve adjustment.</li> <li>3. Replace air cleaner.</li> <li>4. Replace with proper fuel.</li> </ol>
<b>EXCESSIVE OIL CONSUMPTION</b>	<p><b>OIL LEAKAGE</b></p> <ol style="list-style-type: none"> <li>1. Defective oil seals.</li> <li>2. Broken gear case gasket.</li> <li>3. Loose gear case attaching bolts.</li> <li>4. Loose drain plug.</li> <li>5. Loose oil pipe connector.</li> <li>6. Broken rocker cover gasket.</li> <li>7. Loose rocker cover attaching bolts.</li> </ol>	<ol style="list-style-type: none"> <li>1. Replace oil seals.</li> <li>2. Replace gasket.</li> <li>3. Retighten bolts.</li> <li>4. Retighten plug.</li> <li>5. Retighten oil connections.</li> <li>6. Replace gasket.</li> <li>7. Retighten attaching bolts.</li> </ol>
	<p><b>OIL LEVEL RISING</b></p> <ol style="list-style-type: none"> <li>1. Dead cylinder.</li> <li>2. Displaced or twisted connecting rod.</li> <li>3. Worn piston ring.</li> </ol>	<ol style="list-style-type: none"> <li>1. Check compression.</li> <li>2. Replace connecting rod.</li> <li>3. Replace ring.</li> </ol>
<b>ENGINE BACKFIRES, MISFIRES</b>	<ol style="list-style-type: none"> <li>1. Incorrect valve clearances.</li> <li>2. Lean fuel/air mixture</li> <li>3. Restricted exhaust.</li> </ol>	<ol style="list-style-type: none"> <li>1. Adjust valves and clearances.</li> <li>2. Check carburetor.</li> <li>3. Check catalyst/exhaust.</li> </ol>

# BCG ENGINE TROUBLESHOOTING

PROBLEM	PROBABLE CAUSE	VERIFICATION/REMEDY
<b>ABNORMAL SOUND OR NOISE</b>	<b>CRANKSHAFT AND MAIN BEARING</b> 1. Badly worn bearing. 2. Badly worn crankshaft. 3. Melted bearing.	1. Replace bearing and grind crankshaft. 2. Grind crankshaft. 3. Replace bearing and check lubrication system.
	<b>CONNECTING ROD AND CONNECTING ROD BEARING</b> 1. Worn connecting rod big end bearing. 2. Worn crankpin. 3. Bent connecting rod.	1. Replace bearing. 2. Grind crankshaft. 3. Correct bend or replace.
	<b>PISTON, PISTON PIN, AND PISTON RING</b> 1. Worn cylinder. 2. Worn piston pin. 3. Piston seized. 4. Piston seized and ring worn or damaged.	1. Rebore cylinder to oversize and replace piston. 2. Replace piston. 3. Replace piston and rebore cylinder. 4. Replace piston and rings.
	<b>VALVE MECHANISM</b> 1. Worn camshaft. 2. Excessive valve clearance. 3. Worn timing gear. 4. Worn fan pulley bearing.	1. Replace. 2. Adjust. 3. Replace. 4. Replace.
<b>LOW COMPRESSION</b>	<b>MAIN ENGINE TROUBLES</b> 1. Incorrect valve clearance. 2. Inadequate contact of valve seat. 3. Valve stem seized. 4. Broken valve spring. 5. Compression leaks through cylinder head gasket. 6. Piston ring seized. 7. Worn piston ring and cylinder, 8. Worn engine bearings.	1. Adjust valve clearance. 2. Lap valve. 3. Replace valve and valve guide. 4. Replace valve spring. 5. Replace gasket. 6. Replace piston and piston ring. 7. Overhaul engine. 8. Overhaul engine.
<b>EXCESSIVE FUEL CONSUMPTION</b>	1. Noisy knocking. 2. Smoky exhaust. 3. Moving parts nearly seized or excessively worn. 4. Poor compression. 5. Improper valve timing. 6. Improper valve clearance.	1. See <i>KNOCKING</i> . 2. See <i>SMOKY EXHAUST</i> . 3. Repair or replace. 4. See <i>LOW COMPRESSION; HARD STARTING</i> . 5. Adjust. 6. Adjust.
	<b>INSUFFICIENT INTAKE AIR</b> 1. Air intake obstructed. <b>NOZZLE TROUBLES</b> 1. Seized nozzle. 2. Worn nozzle.	1. Remove obstruction.  1. Replace. 2. Replace.
<b>KNOCKING</b>	<b>ENGINE KNOCKS WITHOUT MUCH SMOKE</b> 1. Main engine troubles. a. Overheated cylinder. b. Carbon deposits in cylinder. <b>KNOCKING WITH DARK SMOKE</b> 1. Poor compression.	a. See <i>OVERHEATING; LOW OUTPUT</i> . b. Clean.  1. See <i>LOW COMPRESSION; HARD STARTING</i> .
<b>LOW OIL PRESSURE</b>	1. Worn Bearings. 2. Relief valve malfunction. 3. Clogged oil cooler/filter. 4. Diesel dilution of the oil.	1. Engine overhaul replace bearings. 2. Overhaul oil pump. 3. Repair and replace. 4. Injection pump repair.

# GENERATOR/ENGINE DISASSEMBLY

## DESCRIPTION

The engine component of the BC generator is not as bulky or heavy as most engines (approx. 75 lbs) so it can be disassembled and repaired on a sturdy work bench. make certain however that the engine is securely fastened so it can not topple off the bench and that the bench also is secure and can not tip over.

Set the generator breakers and panel switches in the off position. Disconnect the AC wiring connections at the terminal block/circuit breaker and unplug the harness at the control pane. Disconnect the battery cable connections and the engine ground cables.

Close off the raw water seacock and disconnect the raw water components. Separate the exhaust at the water injection elbow and disconnect the fuel supply.

**CAUTION:** Make certain the fuel lines are closed off and drained. Clean up all fuel and oil spills and properly dispose of the rags.

Unfasten the generator from its mounting rails or the mounting rails from the platform and remove the generator from the boat.

Once the generator is securely mounted on the work bench, drain the engine oil and coolant.

Remove the starter motor. Disconnect and remove the wiring harness, be certain to tag all the wiring connections so you can separate them.

Separate the generator back-end from the engine. Once the housing is removed, the remaining generator components can be disassembled from the engine back-plate.

**NOTE:** For servicing and testing of the back-end (generator), refer to the GENERATOR section in this manual.

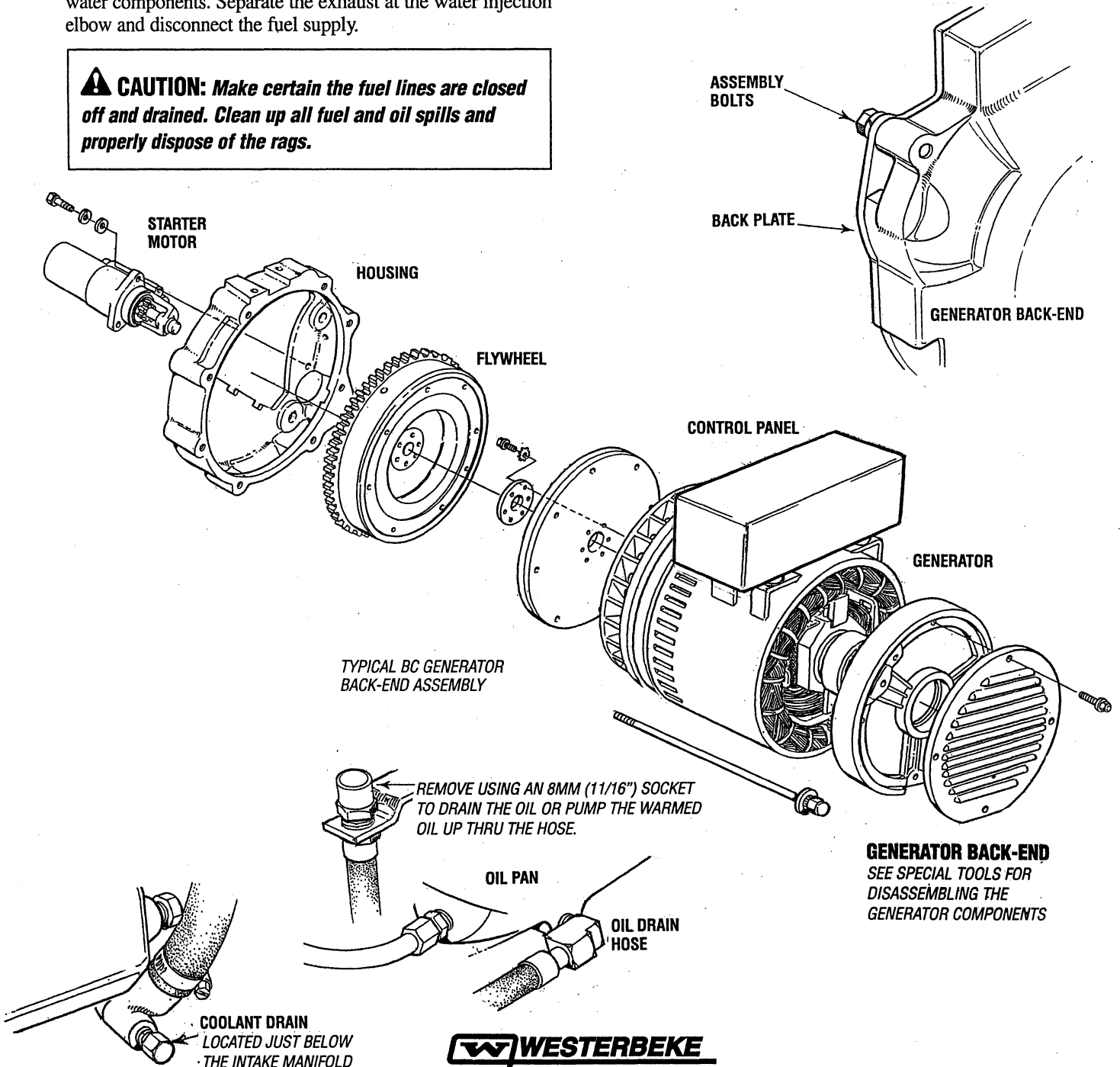

# ENGINE ASSEMBLY

## GENERAL INFORMATION

- Be careful not to mix bolts and nuts. Metric and S.A.E. bolts are used on various engine assemblies.
- During assembly, recheck clearances and insure that parts are being assembled in their proper order and facing in the correct direction in relation to the engine block, such as, pistons, piston rings, bearings and bearing caps.
- Apply lubricating oil to moving parts during assembly. Insure that moving parts, when assembled on the engine, rotate or slide and are not subject to binding or excessive tension.
- If there are mating marks scribed during disassembly, reference them correctly for assembly.
- Use new gaskets, lockwashers, O-rings, packings and seals.
- Tighten the bolts and nuts on important parts of the engine to specified torques using a reliable torque wrench.
- When required, use liquid sealants when required on nuts, bolts and gaskets. Refrain from using tape sealants.
- Most gaskets and many bolt washers are asymmetrical, make certain they are positioned properly.

## Torquing Hardware

Prevent mechanical damage by running fasteners down in three steps-1/2, 2/3, and 1/1 torque. Exceptions are torque-to-yield bolts and rocker arm shaft fasteners. The former are torqued as indicated. The latter-rocker shaft fasteners-should be brought down in very small increments, working from the center bolts out. Gaskets, especially head gaskets, might be damaged during assembly, they should be positioned with great care. See *TORQUE SPECIFICATIONS* thru out this manual.

## Sealants and Lubricants

Oil based PERMATEX #2 and its HIGH TACK equivalent are excellent all purpose sealers. They are effective in just about any joint in contact with coolant, raw water, oil, or fuel. A light coating of oil or LIQUID TEFLON can be used on rubber gaskets and o-rings.

LOCTITE hydraulic red sealant should be used on oil adapter hoses and the oil filter assembly.

Coat both surfaces of the oil pan gasket with high temp RED SILICONE SEALER.

When installing gaskets that seal around water (coolant) passages, coat both sides with WHITE SILICONE GREASE.

Do not use sealant when installing a new gasket.

HIGH-COPPER ADHESIVE SPRAYS are useful for holding a gasket in position during assembly.

Specialized gasket sealers such as HYLOMAR work well in applications requiring non-hardening properties. HYLOMAR is particularly effective on copper cylinder-head gaskets and resists fuel, oil, and water.

**NOTE:** *TAPE SEALANTS should be used on pipe plugs and fitting that connect water coolant passages.*

## Bolts and Fasteners

Lightly oil head bolts and other fasteners as you assemble them. Bolts and other plugs that penetrate the water jacket should be sealed with PERMATEX #2 or HIGH TACK.

When assembling the flywheel, coat the bolt threads with LOCTITE blue.

LITHIUM based grease is waterproof, ideal for water pump bearings and stuffing boxes.

Antiseize compounds and thread locking adhesives such as LOCTITE protect threaded components yet allow them to come apart when necessary. LOCKTITE offers levels of locking according to the job.

Heavily oil all sliding and reciprocating components, always use clean engine oil.

# TIMING BELT DISASSEMBLY

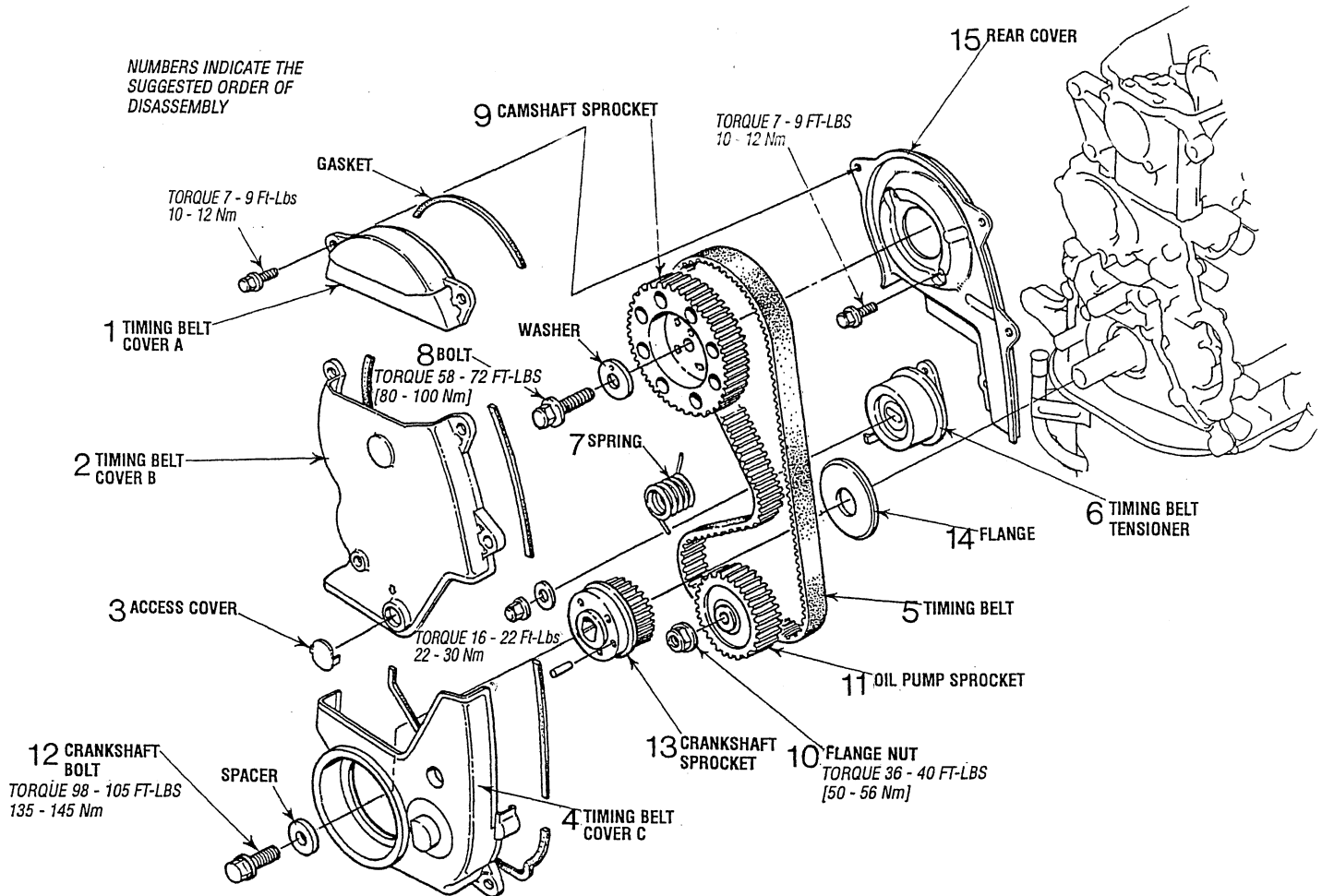

## INSTRUCTIONS FOR INSPECTING AND REPLACING THE TIMING BELT

WESTERBEKE requires as normal maintenance, replacing the timing belt after 1000 engine operating hours. The timing belt should always be replaced during an engine overhaul.

The adjustments, inspection, and replacement procedures may be performed without removing the generator from the boat. THE TIMING BELT PART NUMBER IS #043036

### Timing Belt Removal

1. Turn the crankshaft clockwise to align the timing mark on the camshaft sprocket and timing belt rear cover.

**NOTE:** Always turn the crankshaft clockwise.

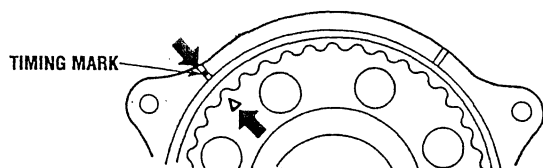

2. Remove the plug on the left surface of the cylinder block and insert a rod with a diameter of 0.31 in (8 mm) to lock the counterbalance shaft.

**NOTE:** Be sure to use an inserting rod with a diameter of 0.31 in (8 mm).

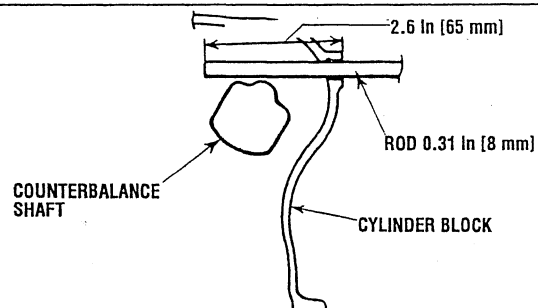

3. Loosen the timing belt tensioner nut.
4. Move the timing belt tensioner toward the water pump, and temporarily tighten the nut to hold the tensioner in that position.

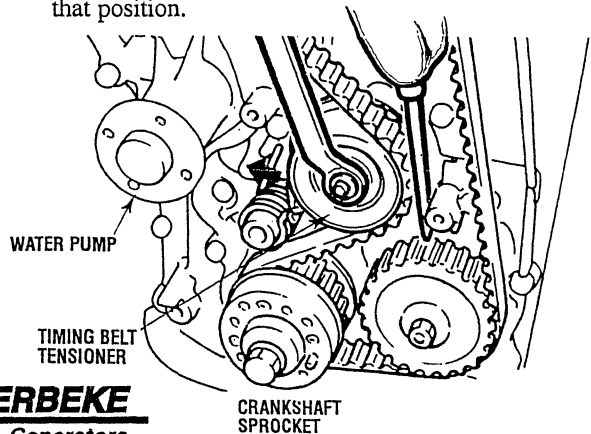

**WESTERBEKE**  
Engines & Generators

# TIMING BELT DISASSEMBLY

5. Remove the timing belt.

**NOTE:** If the timing belt is to be reused, draw an arrow on the belt to indicate the direction of rotation (clockwise).

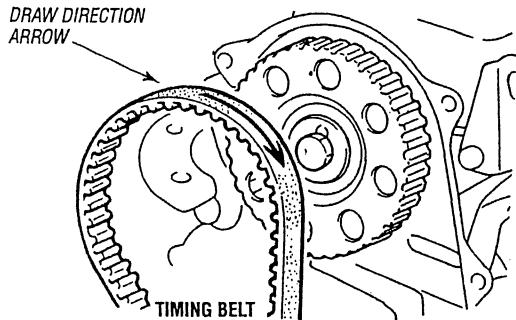

## Camshaft Sprocket Removal

1. Remove the camshaft sprocket bolt without turning the camshaft.

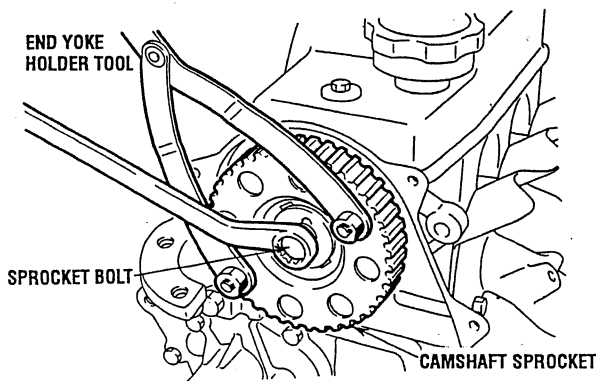

## Oil Pump Sprocket Flange Nut Removal

1. Remove the plug from the left side of the cylinder block.
2. Insert an 0.31 in (8 mm) diameter round bar to lock the counterbalance shaft.
3. Remove the oil pump sprocket flange nut.

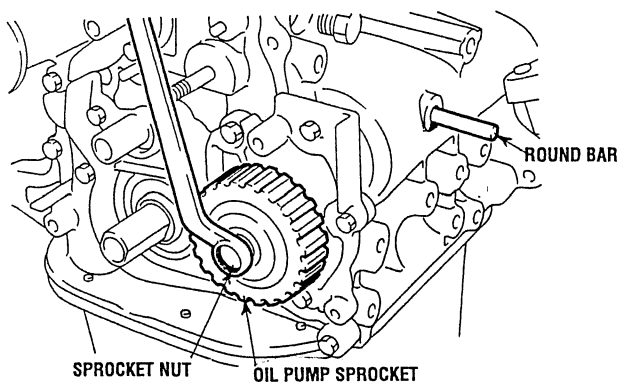

## Crankshaft Bolt Removal

1. Lock the crankshaft in position.

**NOTE:** Do not turn the crankshaft.

2. Remove the crankshaft bolt.

## Timing Belt Inspection

Replace the belt if any of the following conditions exist:

- Hardening of the back rubber, leaves no indent when pressed with fingernail (back side is glossy).
- Cracks on rubber back.
- Cracks or peeling of canvas.
- Cracks on tooth bottom.
- Cracks on belt.
- Abnormal wear of belt sides. The sides are normal if they are sharp as if cut by a knife.
- Abnormal wear on teeth.
- Tooth missing and canvas fiber exposed.

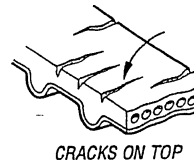
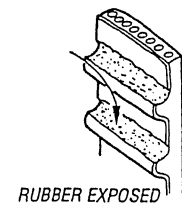
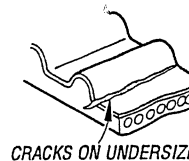
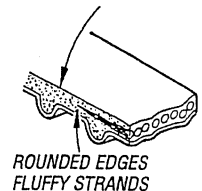
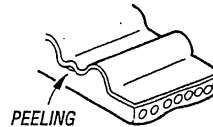
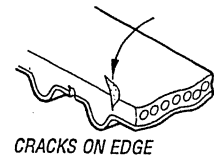
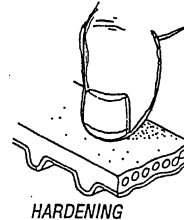

## Tensioner Inspection

1. Replace the tensioner if the pulley binds, rattles or is noisy when turned.

# ENGINE TIMING BELT

## Flange Installation

1. Mount the flange so that its side shown by the heavy arrow in the illustration faces toward the sprocket.

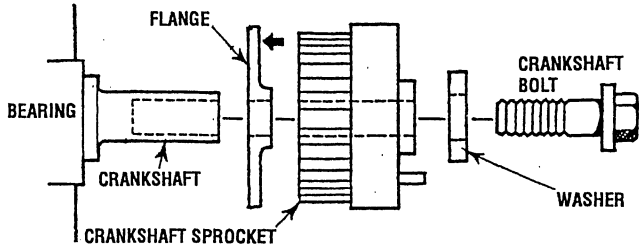

## Crankshaft Bolt Installation

1. Lock the crankshaft.  
**NOTE:** Do not turn the crankshaft.
2. Tighten the crankshaft bolt to the specified torque.

## Oil Pump Sprocket Flange Nut Installation

1. Insert the round bar into the plug hole in the left side of the cylinder block to keep the counterbalance shaft from turning.
2. Install the oil pump sprocket.
3. Tighten the nut to the specified torque.

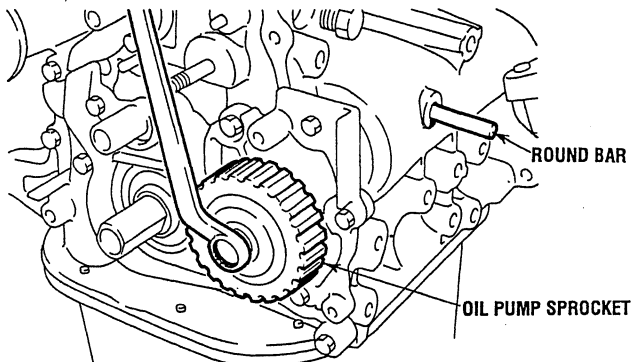

## Camshaft Sprocket Bolt Installation

1. Tighten the bolt to the specified torque.  
**CAMSHAFT BOLT TORQUE 58 - 72 Ft-lbs (80 -100 Nm)**

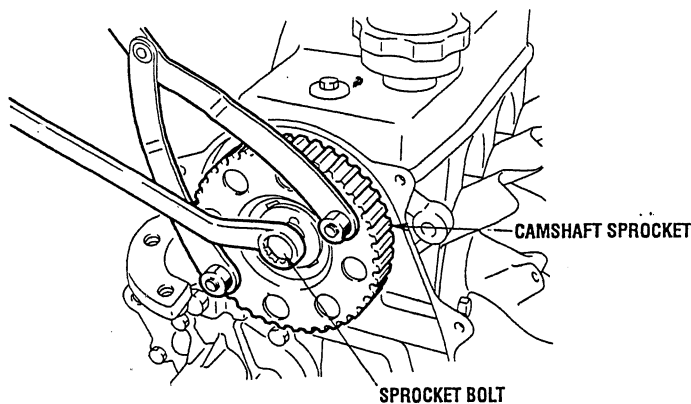

## Tensioner Spring/Timing Tensioner Installation

1. Install the tensioner spring and timing belt tensioner.
2. Hook the tensioner spring onto the bend of the timing belt tensioner bracket and the stopper pin on the cylinder block.
3. Move the timing belt tensioner as close as possible to the water pump; temporarily tighten the tensioner nut.

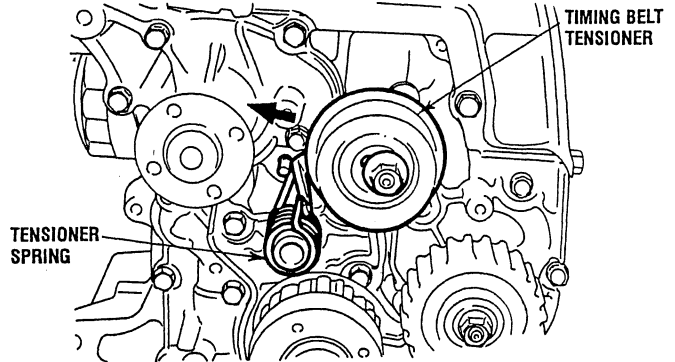

## Timing Belt Installation

1. Align the triangular marking on the camshaft sprocket with a marking on the timing belt rear cover.
2. Align the notch in the crankshaft sprocket flange with the marking on the front case.
3. Align the triangular marking on the oil pump sprocket with the marking on the front case, and then insert a 2.56 in. (65 mm.) or longer, 0.31 in (8mm.) diameter round bar into the plug hole in the left side of the cylinder block.

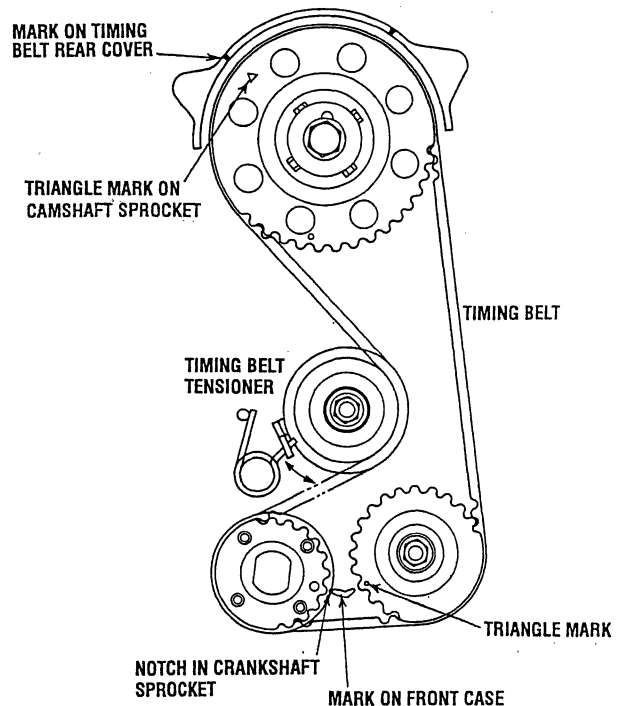



# ENGINE TIMING BELT

At this time, check that the moveable range of teeth on the oil pump sprocket is according to specifications.

**STANDARD VALUE:** 4 to 5 teeth in forward direction.  
1 to 2 teeth in reverse direction.

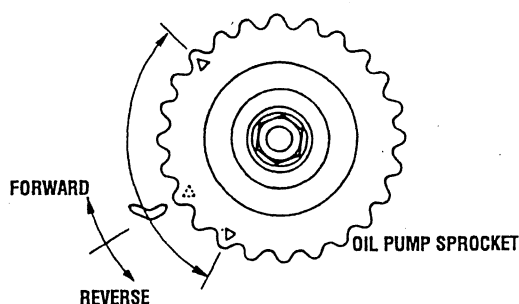

4. If the movable range of the teeth on the oil pump sprocket exceeds the specified range, correct as follows:
  - a. Pull out the round bar from the plug hole in the left side of the cylinder block.
  - b. Turn the oil pump sprocket one turn at a time until the round bar can again be inserted.
  - c. Check that the movable range of the oil pump sprocket is in the specified value.

5. Set the timing belt over the crankshaft sprocket and then over the oil pump sprocket and camshaft sprocket, in that order.

**NOTE:** Ensure that the tension side of the timing belt is not slack. Keep the round bar inserted until the timing belt has been placed. After this step, be sure to remove the round bar.

6. Apply counterclockwise force to the camshaft sprocket to make the belt taut on the tension side, and make sure that all timing marks are lined up.

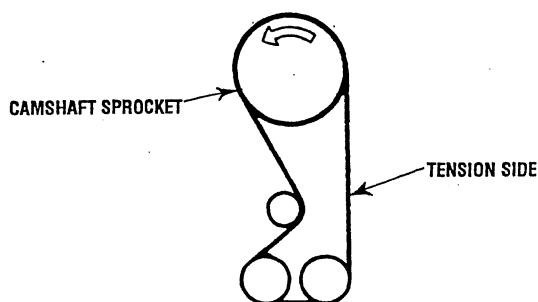

7. Loosen the temporarily tightened tensioner nut on the water pump side 1 or 2 turns, and tension the belt making use of the spring force.

8. Turn the crankshaft *clockwise* by nine camshaft sprocket teeth (81°) to align the timing mark on the camshaft sprocket with the tensioner set mark on the timing belt rear cover.

**CAUTION:** This operation is performed to give a proper tension to the timing belt, so do not turn the crankshaft counterclockwise and push the belt to check the tension.

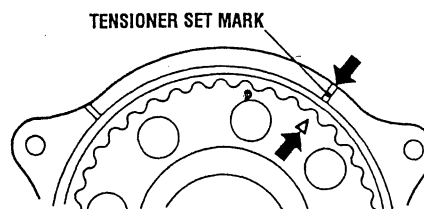

9. Make sure that the timing belt teeth are engaged with the camshaft sprocket teeth along the portion of the sprocket shown by the curved arrow in the illustration below. Then tighten the tensioner nut.
10. Pull the timing belt in the center of the tension side toward the sealing gasket line for the belt cover, as illustrated. Make sure that the clearance between the back of the belt and the sealing line is the standard value.

**STANDARD VALUE:** 0.47in. (12mm)

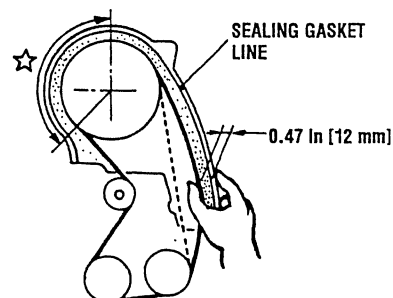

11. Pull out the rod from the plug hole on the left surface of the cylinder block and apply the specified sealant. Then tighten the plug to the specified torque.

Specified sealant value: 3M ATD Part No. 8660 or equivalent.

**TIGHTENING TORQUE:** 11-16 ft.lbs. (15-22 Nm)

# ENGINE DISASSEMBLY

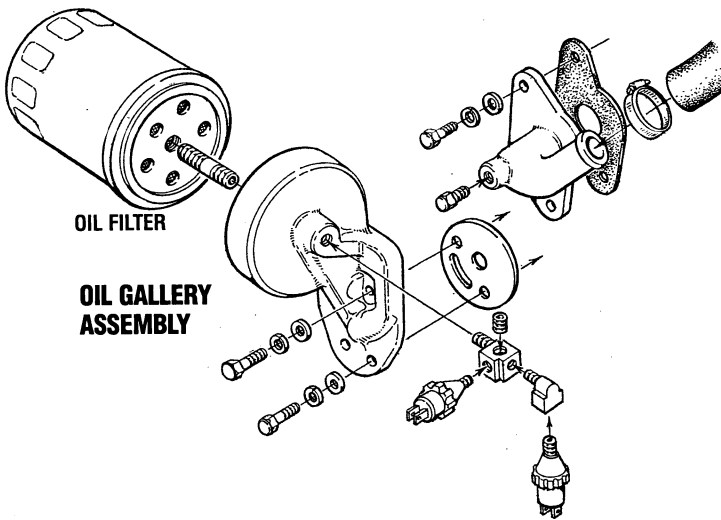

OIL FILTER

OIL GALLERY ASSEMBLY

Remove the thermostat assembly and clean the interior chambers. Inspect the seals in the pressure cap when reassembling. Replace the thermostat and gasket.

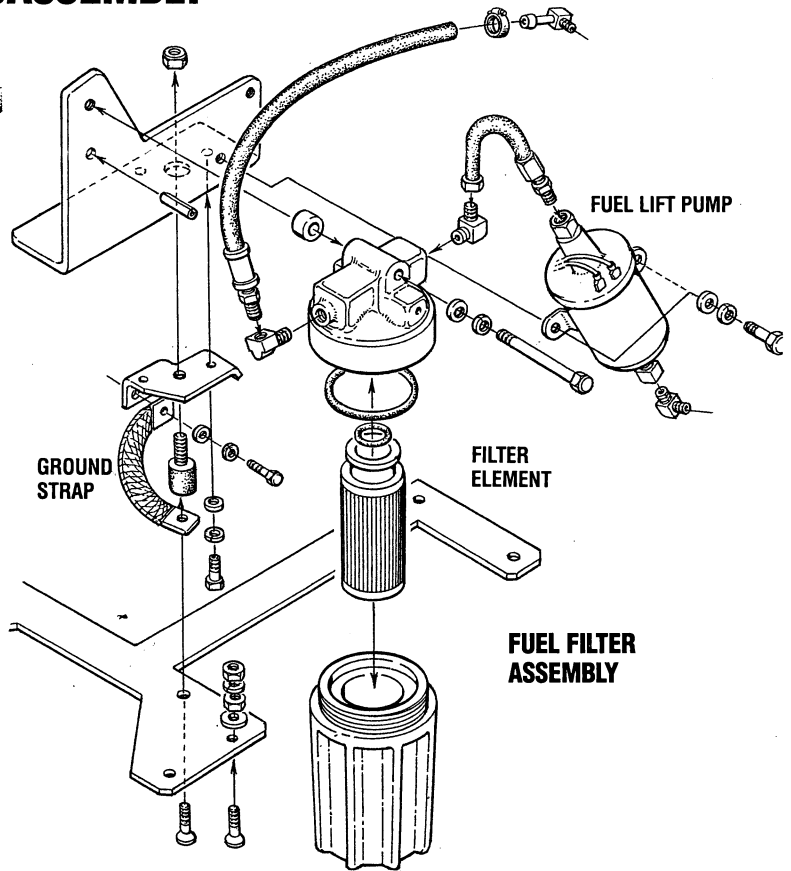

FUEL LIFT PUMP

GROUND STRAP

FILTER ELEMENT

FUEL FILTER ASSEMBLY

Drain and inspect the fuel hoses. Inspect the O-ring and replace the filter element.

Remove the engines coolant pump. For servicing, refer to *COOLANT PUMP*.

Detach and remove the ignition wires, the distributor and spark plugs. Refer to *DISTRIBUTOR DISASSEMBLY* in this manual.

See *ENGINE ADJUSTMENTS* for information on ignition wires and spark plugs.

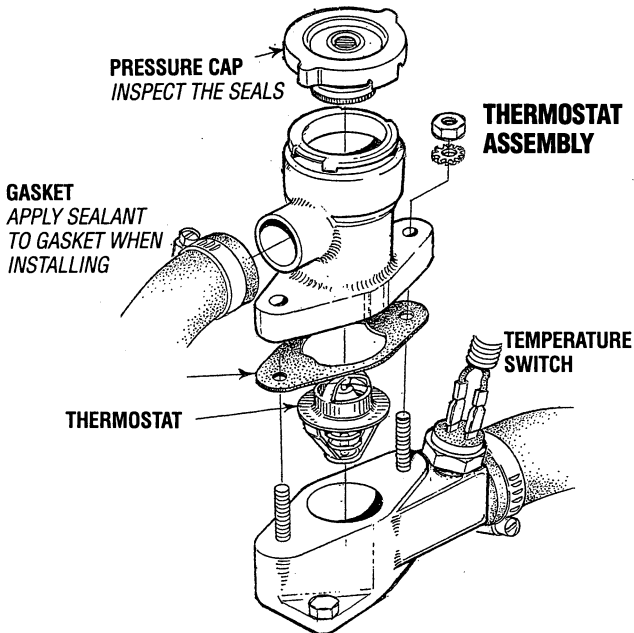

PRESSURE CAP  
INSPECT THE SEALS

THERMOSTAT ASSEMBLY

GASKET  
APPLY SEALANT TO GASKET WHEN INSTALLING

TEMPERATURE SWITCH

THERMOSTAT

Loosen the raw water pump, remove the drive belt and then remove the raw water pump.

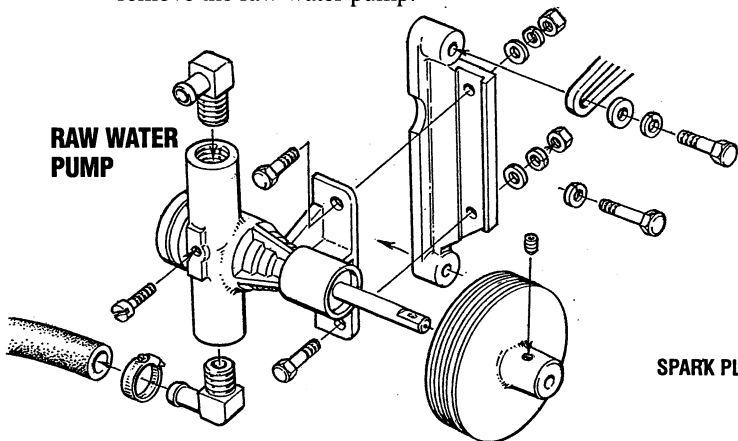

RAW WATER PUMP

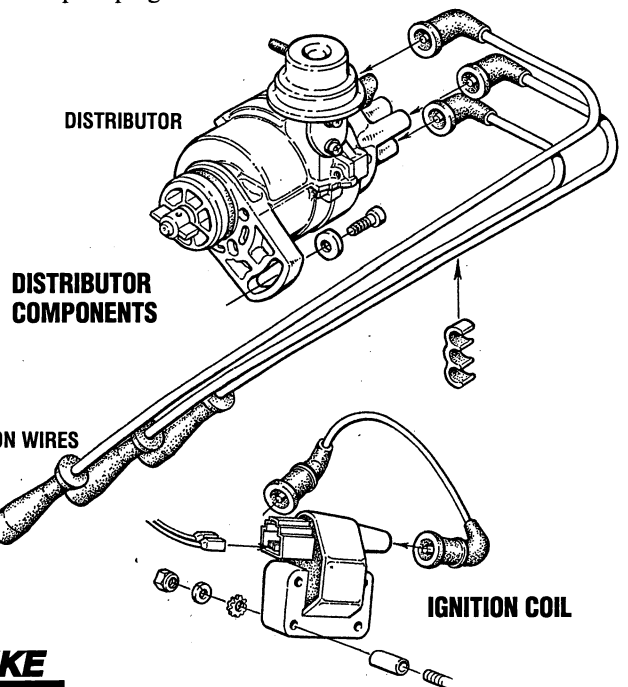

DISTRIBUTOR

DISTRIBUTOR COMPONENTS

IGNITION WIRES

SPARK PLUGS

IGNITION COIL

# CYLINDER HEAD AND VALVES

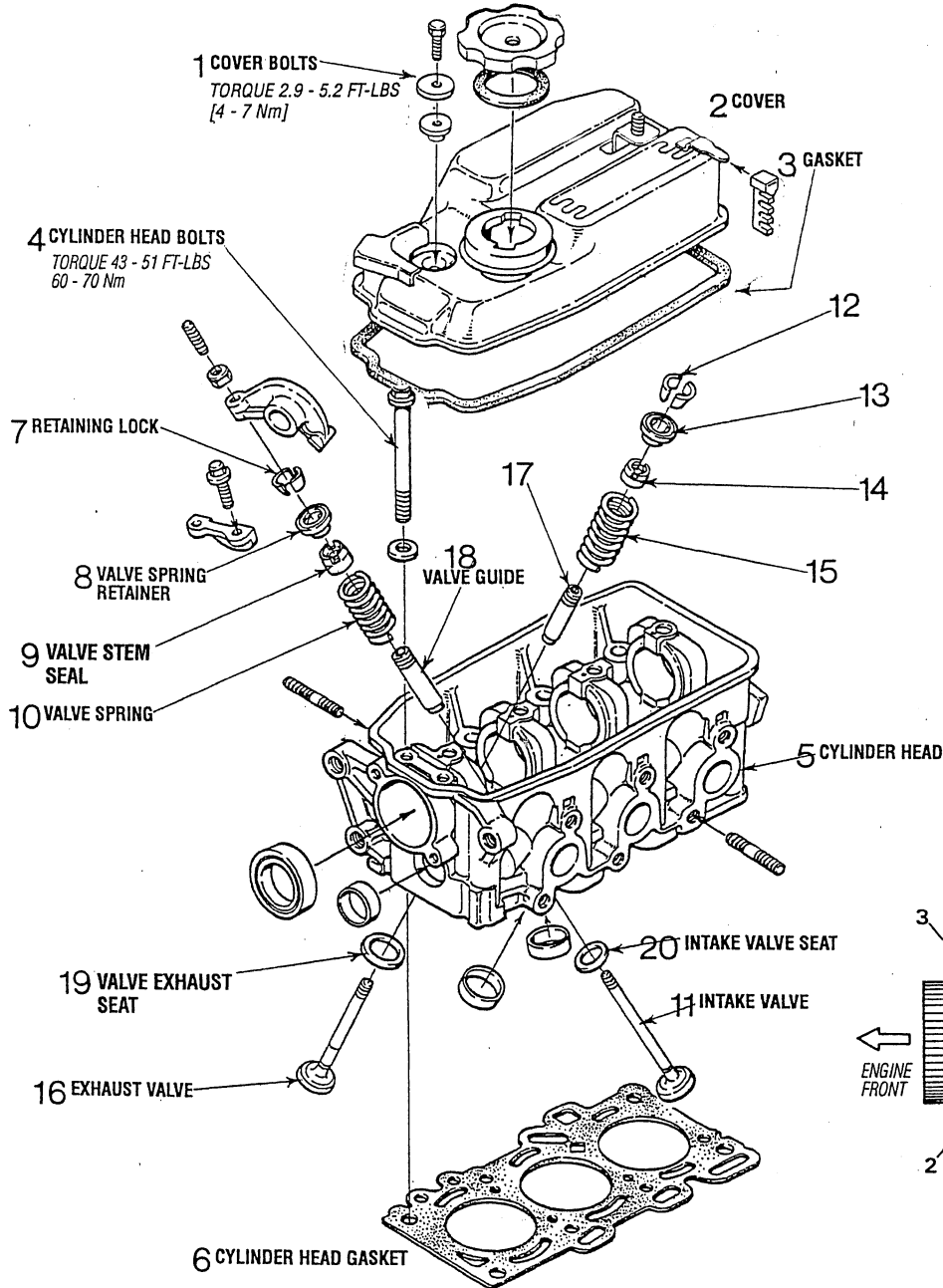

NUMBERS INDICATE THE SUGGESTED ORDER OF DISASSEMBLY

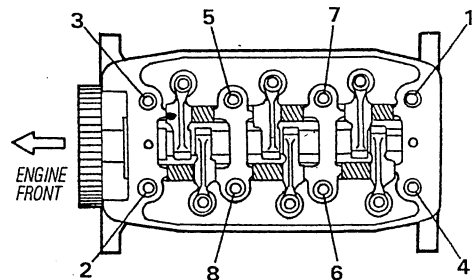

**CYLINDER HEAD BOLTS LOOSENING SEQUENCE**

## REMOVING THE CYLINDER HEAD FROM THE CYLINDER BLOCK

Disassemble the cover bolts as shown above, taking care not to lose the washer and insert. Remove the rocker cover and rocker cover gasket.

Loosen each of the cylinder head bolts, a little at a time so as to avoid the possibility of distorting the cylinder. Repeat several times until the bolts are unfastened. Follow the sequence shown in the diagram.

Remove the cylinder head and the cylinder head gasket.

Remove the valve retainers, valve springs and valves from the cylinder head. When removing each valve retainer, depressing the retainer against the valve spring and remove the retainer lock. Identify each valve by putting a mark indicating the number of the cylinder from which the valve was removed.

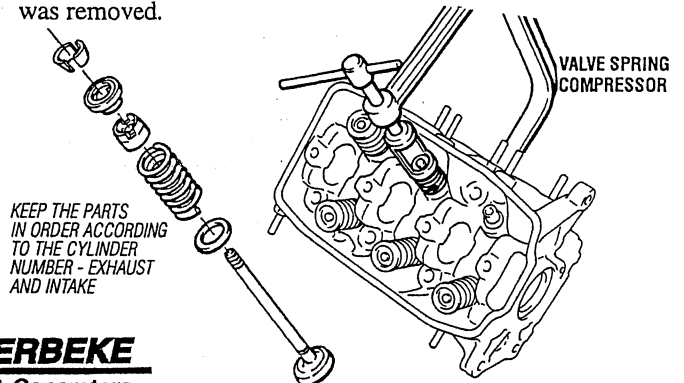

# CYLINDER HEAD AND VALVES

Use pliers to remove the valve stem seals. Do not reuse the stem seals.

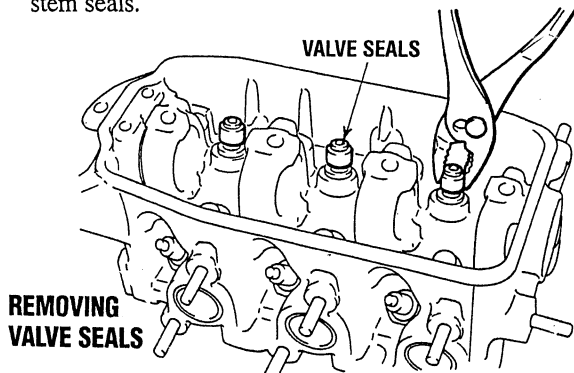

## CYLINDER HEAD INSPECTION

Before cleaning check the cylinder head for water leaks, cracks and other possible damage.

Clean by completely removing the oil, scaling, carbon and sealant. After flushing the oil passage, blow air thru to ensure that no portion of the oil passage is clogged.

To check the cylinder head bottom surface for flatness and distortion, as indicated in the diagram, use a straight edge and a feeler gauge. If distortion exceeds the limit correct by grinding.

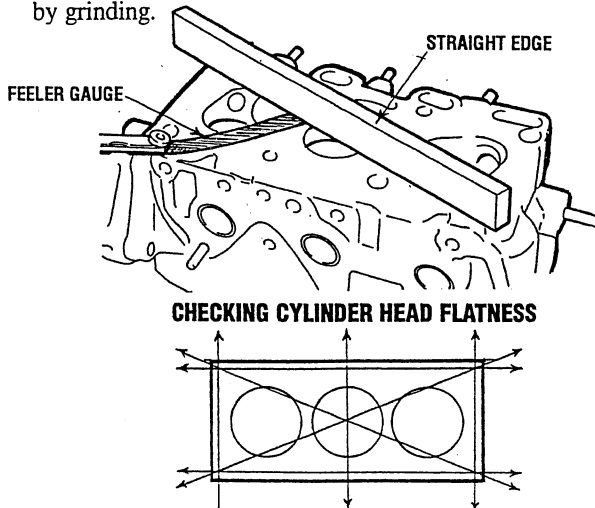

**CYLINDER HEAD FLATNESS**  
Standard 0.0019in (0.05mm) Limit 0.0079in (0.2mm)

**CYLINDER HEAD GRINDING LIMIT**  
0.0079in (0.2mm)  
Total resurfacing depth of cylinder head and block

**CYLINDER HEAD HEIGHT (NEW)**  
4.287 - 4.295in (108.9 - 109.1mm)

**CAUTION:** No more than 0.079in (0.2mm) of stock may be removed from the cylinder head and cylinder block mating surfaces in total.

See the *STANDARDS AND LIMITS CHART* for cylinder head rework dimensions of the valve seat hole.

## VALVE ASSEMBLY INSPECTION

### Valve Stem/Valve Seat

If the valve stem is bent or worn, replace the valve. Check contact between the valve and valve seat by applying a thin coat of Prussion Blue (or Redhead) on the valve seat contact face, then insert the valve into the valve guide and press-fit the valve on the valve seat. Do not rotate the valve.

Check if the valve seat contact face contacts the center position of the valve contact face. If it is not correct concentric, correct the valve seat. If the margin is out of the limit, replace the valve.

#### THICKNESS OF VALVE HEAD MARGIN

	Standard	Limit
Intake	0.039in (1.0mm)	0.020in (0.5mm)
Exhaust	0.051in (1.3mm)	0.031in (0.8mm)

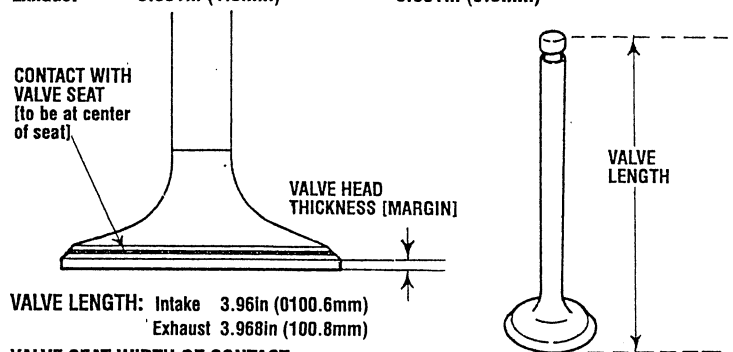

**VALVE LENGTH:** Intake 3.96in (100.6mm)  
Exhaust 3.968in (100.8mm)

**VALVE SEAT WIDTH OF CONTACT**  
Standard 0.035in - 0.051 (0.9 - 1.3mm)

### Valve Spring

Measure the free height of the valve spring and replace the spring if it is out of limit.

**VALVE SPRING FREE LENGTH**  
Standard 1.823in (46.3mm) Limit 1.783in (45.3 mm)

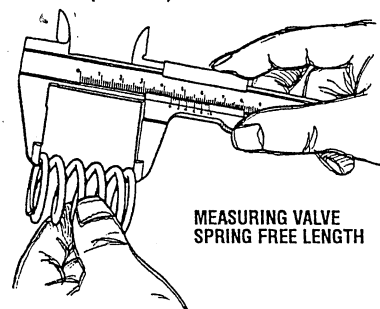

Also check the spring for squareness and if it exceeds the limit replace the spring.

**VALVE SPRING SQUARENESS**  
Standard less than 2° Limit 4°

Refer to the Standards/Limits chart for additional specifications on valves.

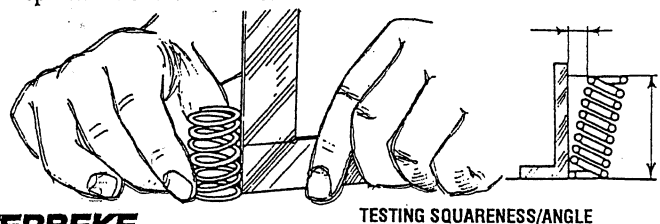

# CYLINDER HEAD AND VALVES

## Valve Stem and Guides

Measure the clearance between the valve guide and the valve stem and, if the clearance exceeds the limit, replace the valve guide or valve, or replace both.

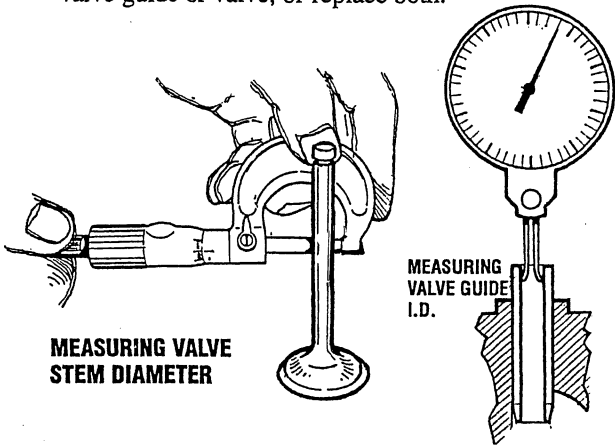

VALVE STEM		TO VALVE GUIDE CLEARANCE
Standard	Intake	0.0008 - 0.0020in (0.02 - 0.05mm)
	Exhaust	0.002 - 0.0033in (0.005 - 0.0085mm)
Limit	Intake	0.0039in (0.10mm)
	Exhaust	0.0059in (0.15mm)

### VALVE STEM OUTER DIAMETER

Standard	Intake	0.2585 - 0.2591in (6.565 - 6.580mm)
	Exhaust	0.2571 - 0.2579in (6.530 - 6.550mm)

## Valve Seat Reconditioning

Before correcting the valve seat, check for clearance between the valve guide and the valve. replace the valve guide if necessary.

To recondition, use a valve and seat cutter and a pilot or a seat grinder, repair so that the seat width and seat angle are the specified configuration.

After correction, the valve and the valve seat should be lapped with lapping compound.

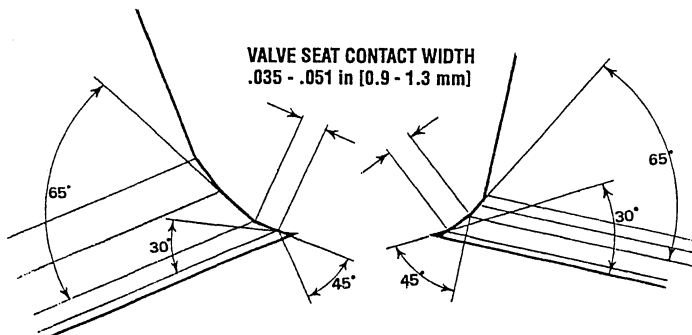

## INSTALLATION

### Valve Stem Seal

Install the valve spring seat, then using the valve stem seal installer, install a new stem seal to the valve guide.

Do not use the old valve stem seal.

**NOTE:** Use the installer tool to insert the stem seal, improper installation can cause oil to leak into the cylinder.

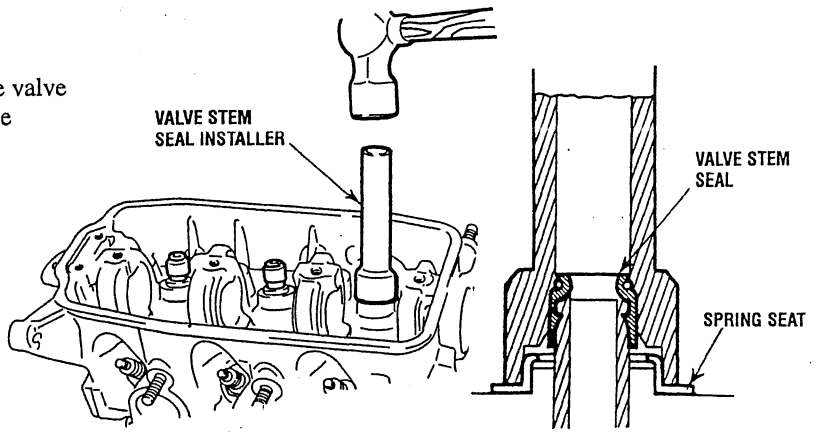

## Valve Springs

Install the valve spring with its enamel coated side toward the rocker arm side.

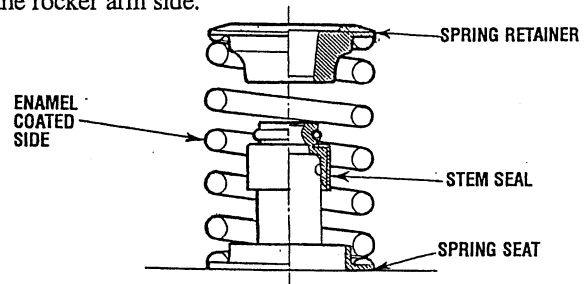

Use the valve spring compressor to compress the valve springs. With the valve spring compressed, remove the retainer locks.

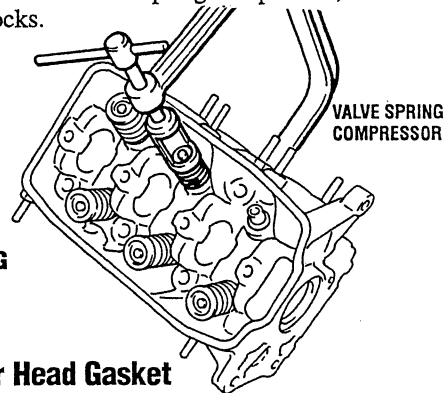

### REMOVING RETAINER LOCKS

## Cylinder Head Gasket

Clean the residue of gasket and oil from the gasket mounting surface of the cylinder block and the cylinder head.

Place a new cylinder head gasket on the cylinder block facing its identification mark upward.

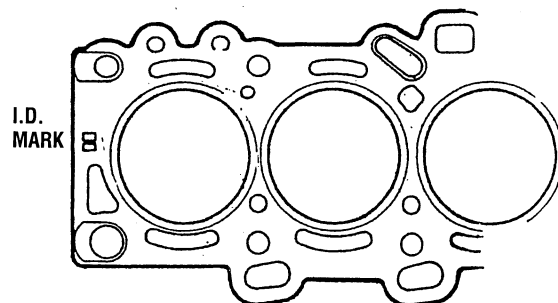

CYLINDER HEAD GASKET

# CYLINDER HEAD AND VALVES

## Cylinder Head Bolts

Tighten the cylinder head bolts in the order shown in the diagram using a stepped-up tightening torque.

1. Temporarily tighten the bolts in numerical order to 14 - 22ft-lbs (20 - 30 Nm).
2. Tighten the bolts again in numerical order to 29 - 36ft-lbs (40 - 50Nm).
3. Tighten the bolts in numerical order to the specified torque.

**CYLINDER HEAD TORQUE** 43 -51ft-lbs (60 - 70Nm)

## Rocker Cover

Install the rocker cover using a new gasket (slightly coat both sides with clean oil). Gradually tighten the cover bolts to the specified torque making certain the cover gasket is positioned properly.

**ROCKER COVER BOLT TORQUE (6mm BOLT)**

2.9 - 5.2 ft-lbs (4 - 7Nm)

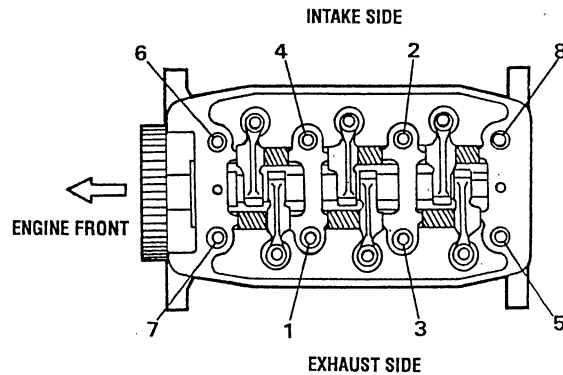

**CYLINDER HEAD BOLTS  
TIGHTENING SEQUENCE**

# CAMSHAFT AND ROCKER ARMS

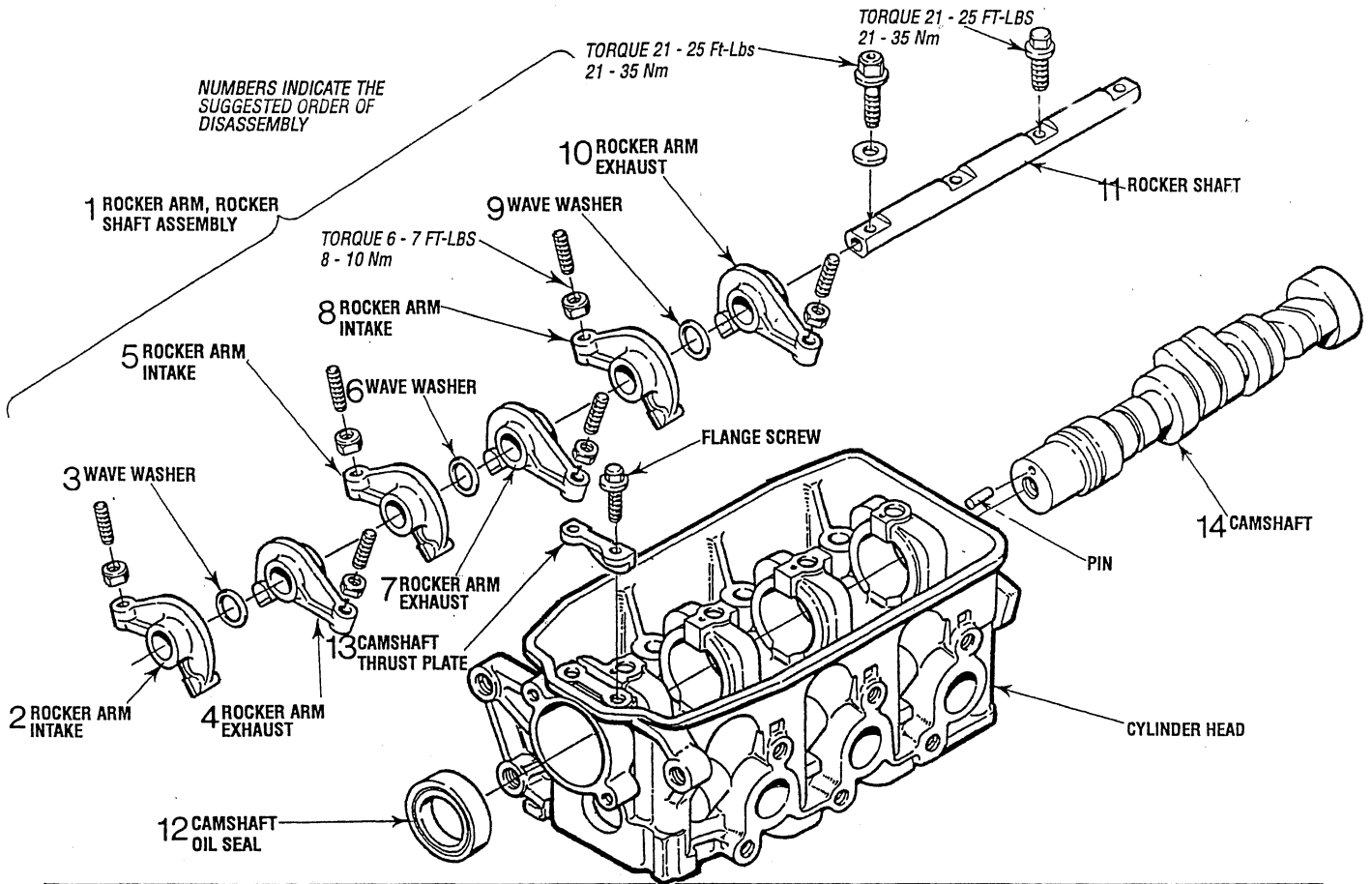

## INSPECTING THE CAMSHAFT

1. Visually inspect the camshaft for cracks and damage. If necessary, replace the camshaft.

**NOTE:** If the damage is slight, you may be able to correct the camshaft with an oil soaked fine emery grindstone. Take special care to not damage the original cam form.

2. Inspect the camshaft journal and, if wearing exceeds the limit, replace the camshaft.

### CAMSHAFT JOURNAL DIAMETER

STANDARD 1.6118 - 1.6124in (40.940 - 40.955mm)

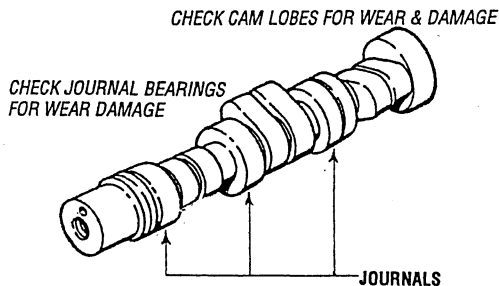

### Camshaft

**NOTE:** If the Journal is seized, also check the cylinder head!

3. Measure the cam height and, if it is less than the limit, replace the camshaft.

CAMSHAFT HEIGHT	STANDARD	LIMIT
Intake	#1 1.3815in (35.09mm)	1.3618in (34.59mm)
	#2 1.3807in (35.07mm)	1.3610in (34.57mm)
	#3 1.3803in (35.06mm)	1.3606in (34.56mm)
Exhaust	#1 1.3839in (35.15mm)	1.3642in (34.65mm)
	#2 1.3831in (35.13mm)	1.3634in (34.63mm)
	#3 1.3854in (35.19mm)	1.3657in (34.69mm)

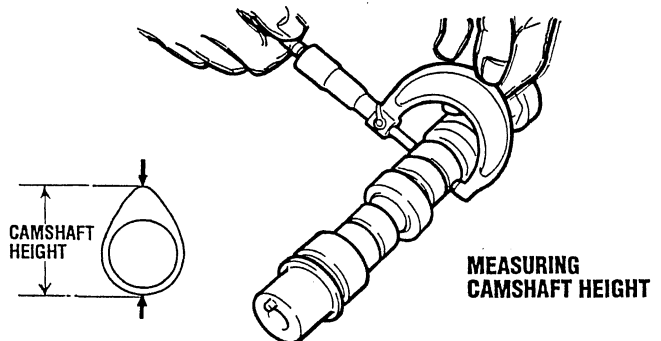

4. Inspect the clearance between the camshaft journal and the camshaft support bore as follows:
  - a. Measure the camshaft journal diameter and the camshaft support bore.
  - b. Calculate the clearance and replace the camshaft or cylinder head if the clearance exceeds the limit.

### BEARING OIL CLEARANCE

STANDARD 0.0018 - 0.0033in (.045 - 0.085mm)

# CAMSHAFT AND ROCKER ARMS

## Rocker Arm

Check each component part of the rocker arm assembly and carefully inspect the individual rockers where the arrows indicate.

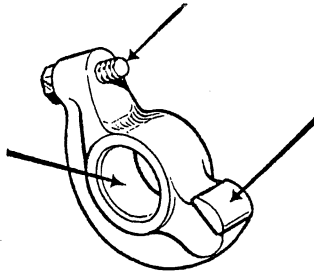

**ROCKER ARM INSPECTION**

## Inspecting Clearance Rocker Arm And Shaft

Check the clearance between the rocker arm and shaft and, if it exceeds the limit, replace the rocker arm or shaft.

### ROCKER ARM CLEARANCE (ROCKER ARM TO SHAFT)

Standard	0.0005 - 0.0017in (0.012 - 0.043mm)
Limit	0.004in (0.1mm)

## Rocker Shaft

1. Inspect the rocker shaft where the rocker arms sit for water and damage. Replace the shaft if worn.
2. Measure the shaft length and the shaft outer diameter (O.D.). If the shaft fails to meet the standards, replace the shaft.

**ROCKER SHAFT LENGTH** Standard 9.134in (232mm)

**ROCKER SHAFT O.D.** Standard 0.6687 - 0.6692in (16.985 - 16.998mm)

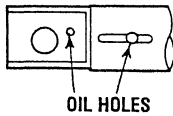

OIL HOLES

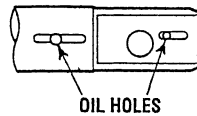

OIL HOLES

## INSTALLATION

1. Apply a coating of engine oil to the camshaft journals and cams and insert the camshaft through the rear of the cylinder head.
2. Install the camshaft thrust plate as shown in the diagram tighten the bolts to the specified torque.

**THRUST PLATE BOLT TORQUE** 7 - 9ft-lbs (10 - 12Nm)

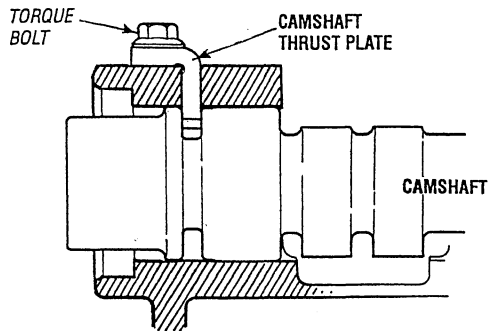

3. Measure the end play of the camshaft by inserting a feeler gauge in the gap between the rear of the thrust plate and the new front camshaft journal.

<b>END PLAY</b>	Standard	0.0024 - 0.0055in (0.6 - 0.14mm)
	Limit	0.118in (0.3mm)

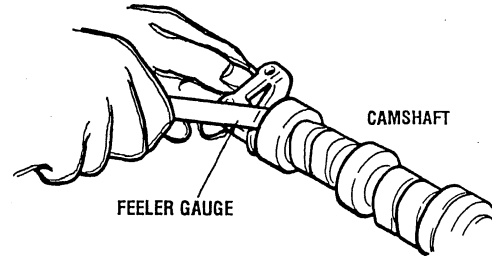

FEELER GAUGE

CAMSHAFT

4. Using the oil seal installer tool, install the front oil seal in the cylinder head.

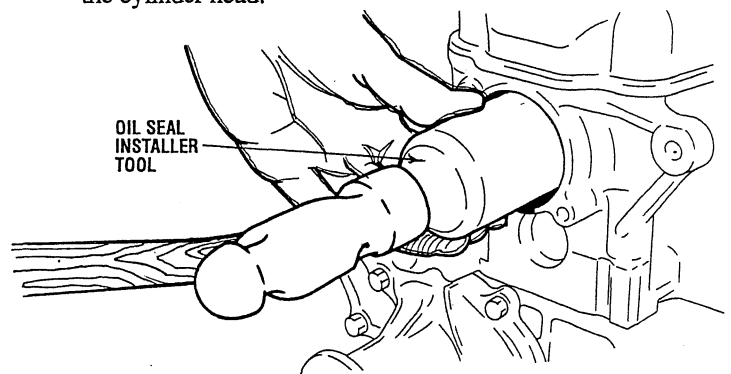

OIL SEAL INSTALLER TOOL

5. Install the rocker arm/rockershaft assembly. Install the rocker shaft so the portion shown in the diagram is located on the front.

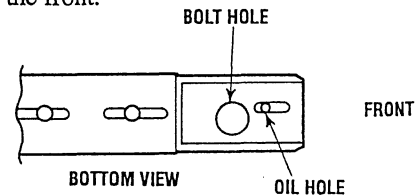

BOTTOM VIEW

OIL HOLE

6. Tighten the rocker arm shaft bolts (4 bolts) uniformly and then to the specified torque.

**ROCKER ARM SHAFT BOLT TORQUE** 21 - 25ft-lbs (29 - 35 Nm)



# PISTONS AND CONNECTING RODS

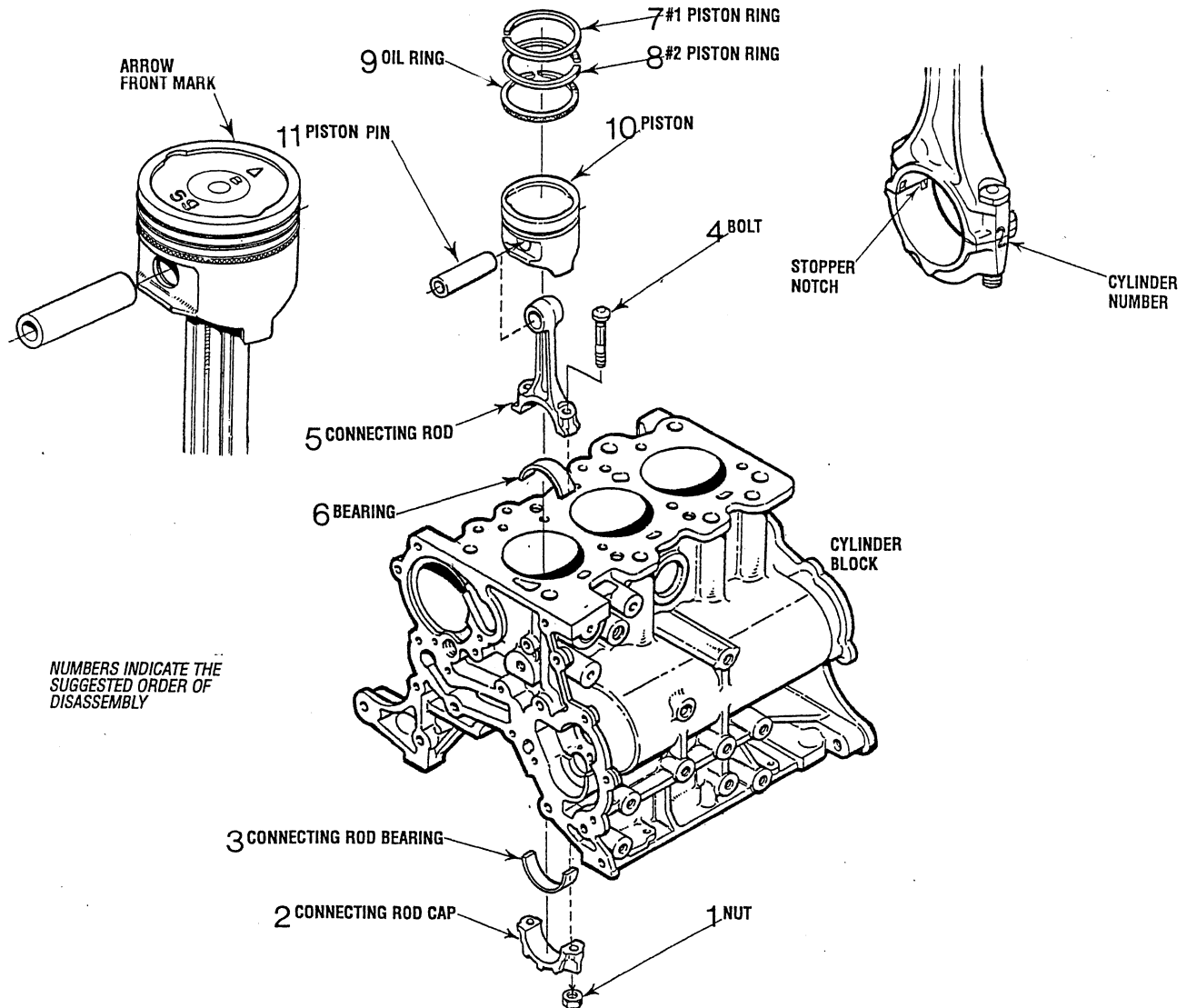

## REMOVING THE CONNECTING RODS/PISTONS

Turn the engine over and remove the connecting rod bearing caps and the connecting rod bearings, note the markings on the bearing cap and keep the disassembled parts (connecting rod, rod cap, piston, etc. classified by cylinder. If the marks are worn away be certain to remark them.

## Disassemble the Pistons

Using the ring remover, remove the piston rings. While removing the piston rings, note the order they are removed and which side of the ring faces the piston crown.

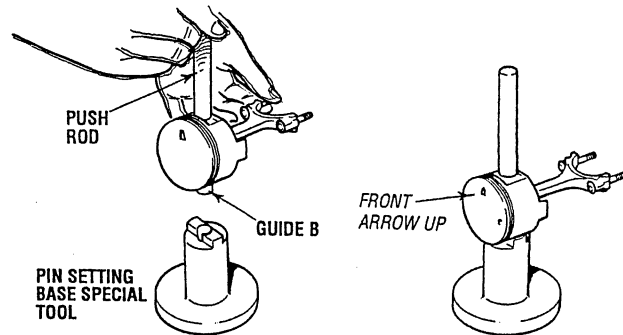
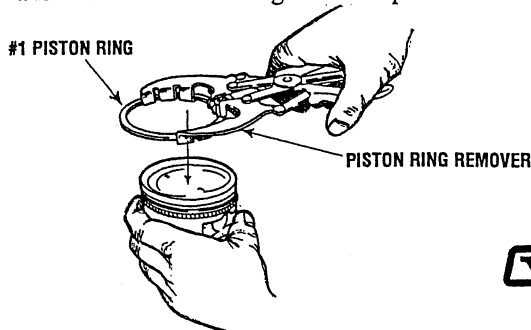

## Remove the Piston Pins

Insert the special tool, push the rod, and guide B into the piston pin then set the piston and connecting rod assembly on the pin setting base. Make certain that the front (arrow) stamped on the piston top surface faces upwards. Using a press, drive out the piston pin.

**NOTE:** Keep the disassembled piston, piston pin and connecting rod in order according to the cylinder number.

# PISTONS AND CONNECTING RODS

## PISTON PIN INSPECTION

Reinsert the piston pin into the piston hole with your thumb. You should feel a slight resistance, if the bore is misaligned the pin will click or bind as it enters. Try the pin from both sides. Replace the piston if the pin can be too easily inserted or if there is excessive play.

**NOTE:** The piston pin and piston are replaced as an assembly. Measure the outside diameter of the piston pin.  
**PISTON PIN O.D.** 0.6300 - 0.6302in (16.001 - 16.007mm)

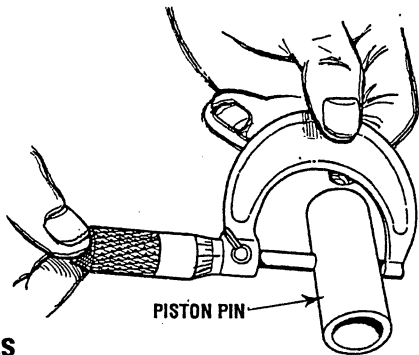

## Pistons

Check the piston surfaces for wear, seizure, cracks and streaking. If any damage is evident, replace the piston. Inspect the oil return hole in the oil ring groove and the oil hole in the piston boss. Clean the piston if these are clogged. Check the piston pin hole for signs of seizure or damage. Replace the piston if damage is evident. Measure the piston diameter at 90° (perpendicular) to the pin bore axis.

**PISTON O.D.** 2.5579 - 2.5591in (64.97 - 65.00mm)

If the piston diameter is less than the standard replace the piston.

**NOTE:** The piston and piston pin are replaced as an assembly.

## Piston Rings

Insert the piston ring into the cylinder bore placing it against the top of the piston head and pressing it in. When it marks a right angle, measure the piston ring gap with a feeler gauge. When the gap is too large, replace the piston ring.

### PISTON RING GROOVE

	Standard
No.1	0.0480 - 0.0488in (1.22 - 1.24mm)
No.2	0.0476 - 0.0484in (1.21 - 1.23mm)
Oil	0.1108 - 0.1116in (2.815 - 2.835mm)

### PISTON RING END GAP

	Standard	Limit
No.1	0.0059 - 0.0118in (0.15 - 0.30mm)	0.8mm (0.0315in)
No.2	0.0138 - 0.0197in (0.35 - 0.50mm)	0.8mm (0.0315in)
Oil	0.008 - 0.028in (0.2 - 0.7mm)	1.0mm (0.0394in)

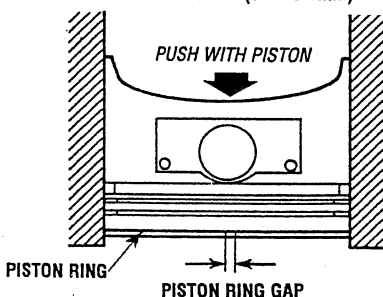

Check the piston ring for damage, wear, seizure and bends replacing the rings if anything unusual is noted. Always replace the piston rings when installing a new piston.

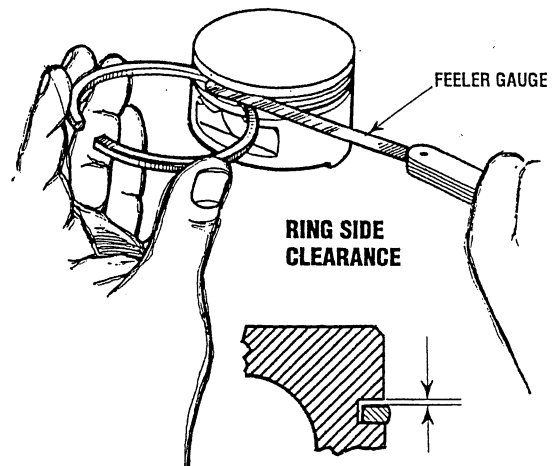

Check the clearance between the piston ring and the ring groove, if it exceeds the limit, replace the rings, the piston or both.

### PISTON RING SIDE CLEARANCE

	Standard	Limit
No.1 ring	0.0012 - 0.0028in (0.03 - 0.07mm)	0.0047in (0.12mm)
No.2 ring	0.0008 - 0.0024in (0.02 - 0.06mm)	0.0039in (0.10mm)

## Connecting Rod Bearing

Visually check the surface of the bearing. Replace those which are lopsided, streaked or seized. When streaks or seizure are excessive, check the crankshaft. If damage is discovered on the crankshaft, either replace it or reuse after undersize machining. If the connecting rod bearing indicates severe thermal damage, replace the bearing.

Measure the inner diameter of the connecting rod bearing and the outer diameter of the crankshaft pin. If the gap (oil clearance) exceeds the limit, replace the bearing, and, if necessary, the crankshaft...or undersize machine the crankshaft and replace the bearings with an appropriate undersize type.

### CONNECTING ROD BEARING OIL CLEARANCE

	Standard	Limit
	0.0009 - 0.0020in (0.022 - 0.052mm)	0.004in (0.1mm)

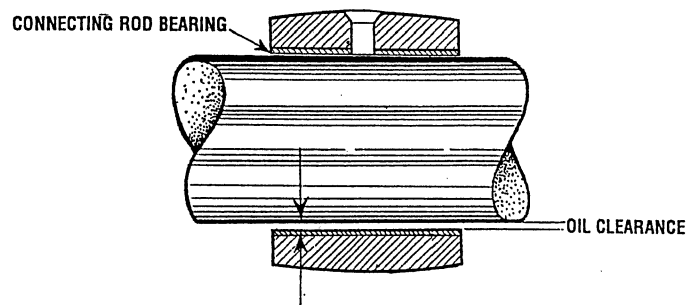

# PISTONS AND CONNECTING RODS

**NOTE:** See Crankshaft/Bearing section for measuring the oil clearance with a Plastigauge.

Use a rod aligner to check the connecting rod for bend and twist.

CONNECTING ROD BEND LIMIT 0.004in (0.1mm)

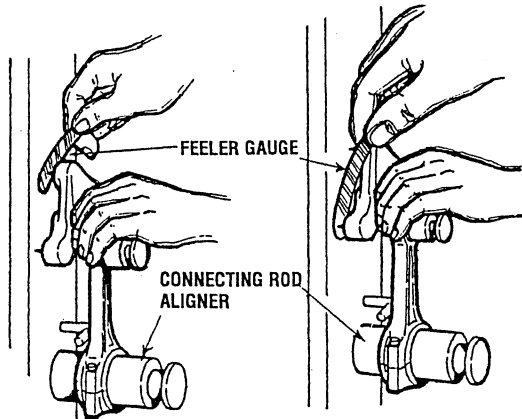

CONNECTING ROD TWIST LIMIT 0.004in (0.1mm)

CONNECTING ROD BIG END TO CRANKSHAFT SIDE CLEARANCE

Standard 0.0039 - 0.0098in (0.10 - 0.25mm) Limit 0.16in (0.4mm)

CONNECTING ROD CENTER LENGTH

Standard 4.0138 - 4.0178in (101.95 - 102.05mm)

## ASSEMBLY

### Piston Connecting Rod, Piston

Using the special tool (pin setting base) assemble the piston and connecting rod and press-in the piston pin. First, install the piston pin into the special tool,

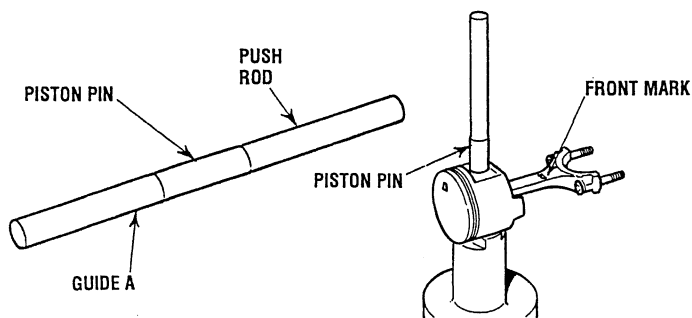

Set up the piston and connecting rod on the piston pin setting base. Make sure that the front marks are facing up. Apply engine oil to the outer circumference of the piston pin and insert the pin, Guide A and the push rod (assembled) into the piston and connecting rod.

Using a press, load the push rod top end and press-fit the piston pin in the connecting rod. The piston pin is press fitted in the specified position by press-fitting the Guide A bottom end surface until it is seated on the bottom surface of the base. If the press-fitting load is out of the specification, replace the pin (piston assembly) or connecting rod, or both.

PISTON PIN PRESS-FITTING LOAD 1102 - 3307lbs (5000 - 15000Nm)

## Oil Ring

Assemble the oil ring spacer into the piston ring groove. Then, after assembling the upper side rail, assemble the lower side rail.

**NOTE:** There is no difference between the upper and lower side rails or the spacers.

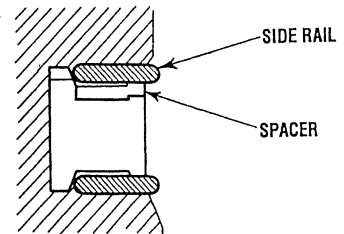

The chart below identifies the color coding on new spacer and side rails according to size.

### SPACER AND SIDE RAIL CODING

SIZE	Color Identification
S.T.D.	
0.0098in (0.25mm) Oversize	Two Blue Lines
0.0197in (0.50mm) Oversize	One Red Line
0.0295in (0.75mm) Oversize	Two red lines
0.0394in (1.00mm) Oversize	One Yellow Line

Install the three-piece oil ring in the piston. Then, make certain the side rails move smoothly in both directions. The side rail may be easily installed by pushing it in with your finger after fitting the one end over the piston groove. Do not use an expander ring on the oil ring.

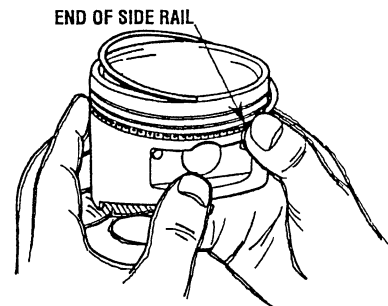

## Piston Rings

Use a piston ring expander and install the piston rings with the marker and size marks facing up toward the piston top. Notice the difference in shapes between No.1 and No.2 ring.

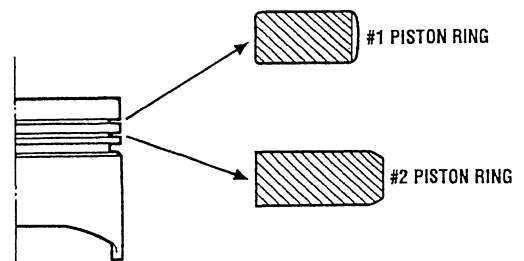

# PISTONS AND CONNECTING RODS

## Installing the Piston Assembly

Apply an ample amount of oil to the outside surfaces of the piston and the piston rings. Position the piston rings and oil ring (side rail spacer) end gaps as shown.

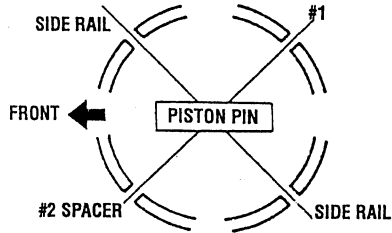

Insert the piston and connecting rod assembly into the cylinder, working from the arrow mark on the piston top toward the camshaft sprocket side.

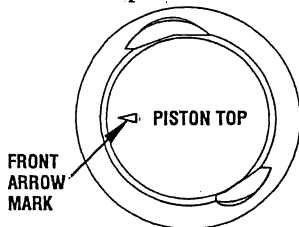

Securely pressing the piston ring with the ring band, insert the piston and connecting rod assembly into the cylinder. Keep in mind that the piston ring may be damaged if hit too strongly.

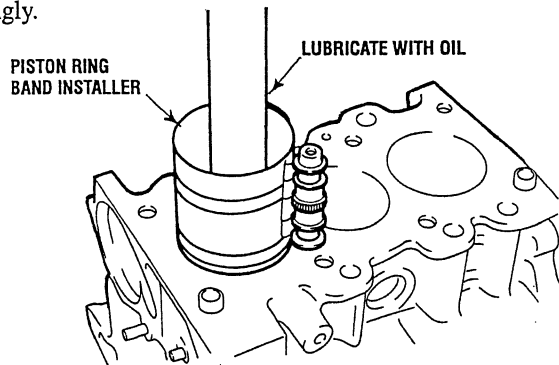

## Crankshaft/Bearing Assembly

When the bearings are to be replaced, select the appropriate bearings for assembly according to the identification marks for the crankshaft and the connecting rod.

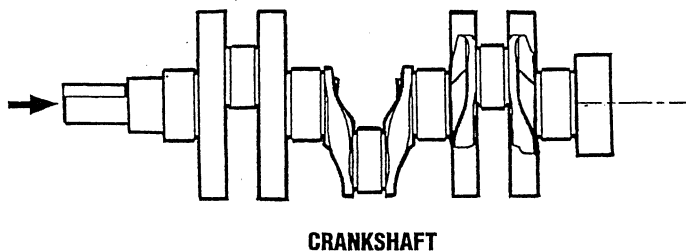

CRANKSHAFT

IDENTIFICATION MARK

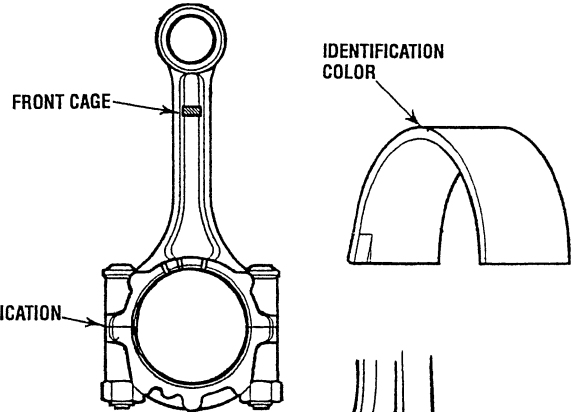

CONNECTING ROD

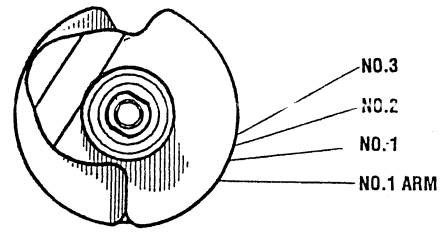
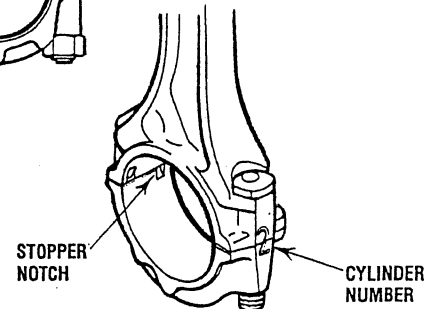

## CRANKSHAFT PIN DIAMETER

Identification marks	Journal Diameter
(1)	1.4171 - 1.4173in (35.995 - 36.000mm)
(2)	1.4167 - 1.4171in (35.985 - 38.995mm)
(3)	1.4165 - 1.4167in (35.980 - 35.985mm)

## CONNECTING ROD BIG END INNER DIAMETER

Identification Marks	Big End Inner Diameter
	1.5354 - 1.5356in (39.000 - 39.005mm)
	1.5356 - 1.5360in (39.005 - 39.015mm)
	1.5360 - 1.5362in (39.015 - 39.020mm)

## CONNECTING ROD BEARING THICKNESS

Identification Color	Bearing Thickness
Brown	0.0586 - 0.0588in (1.488 - 1.493mm)
—	0.0588 - 0.0590in (1.493 - 1.498mm)
Blue	0.0590 - 0.0592in (1.498 - 1.503mm)

## CONNECTING ROD BEARING SELECTION TABLE

Crankshaft Pin Identification Marks	Connecting Rod Bearing Identification Marks
(1)	I Brown
	II Brown
	III —
(2)	I Brown
	II Blue
	III —
(3)	I Blue
	II Blue
	III Blue

# PISTONS AND CONNECTING RODS

## Installing the Connecting Rod Bearing Caps

Since the connecting rod cap bolts and nuts are torqued using the plastic area tightening method, the bolts should be examined before reuse. If the bolt threads are “necked down”, the bolt should be replaced.

Necking can be checked by running a nut with fingers to the full length of the bolt threads. If the nut does not run smoothly, the bolt should be replaced.

Before installation of each nut, apply clean engine oil to the thread portion and bearing surface of the nut.

Install each nut to the bolt and tighten it with your fingers. Then tighten the nuts alternately to install the cap properly. Tighten the nuts to the proper torque.

**CAP NUT TIGHTENING TORQUE 11ft-lb +90 turn (15Nm +90 turn)**

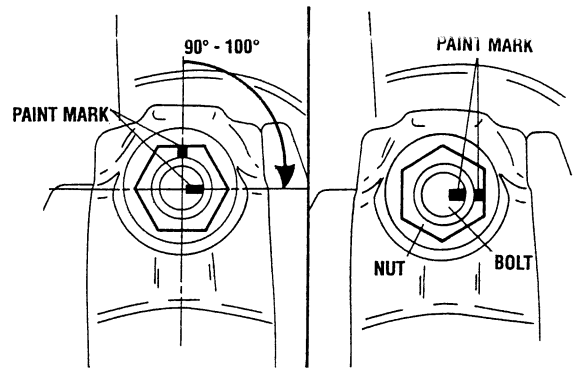

**CAUTION:** *If the cylinder head has been installed before installing the connecting rod cap nut, remove the spark plugs.*

Make a paint mark on the head of each nut. Make a paint mark on the bolt end at the position 90° to 100° from the paint mark made on the nut in the direction of the tightening nut.

Give a 90° to 100° turn to the nut and make sure that the paint mark on the nut and that on the bolt are in alignment.

If the nut is turned less than 90°, proper fastening performance may not be expected. When tightening the nut, turn it sufficiently.

If the nut is overtightened (exceeding 100°), loosen the nut completely and then retighten it by repeating the tightening procedure.

# FRONT CASE / COUNTERBALANCE SHAFT AND OIL PAN

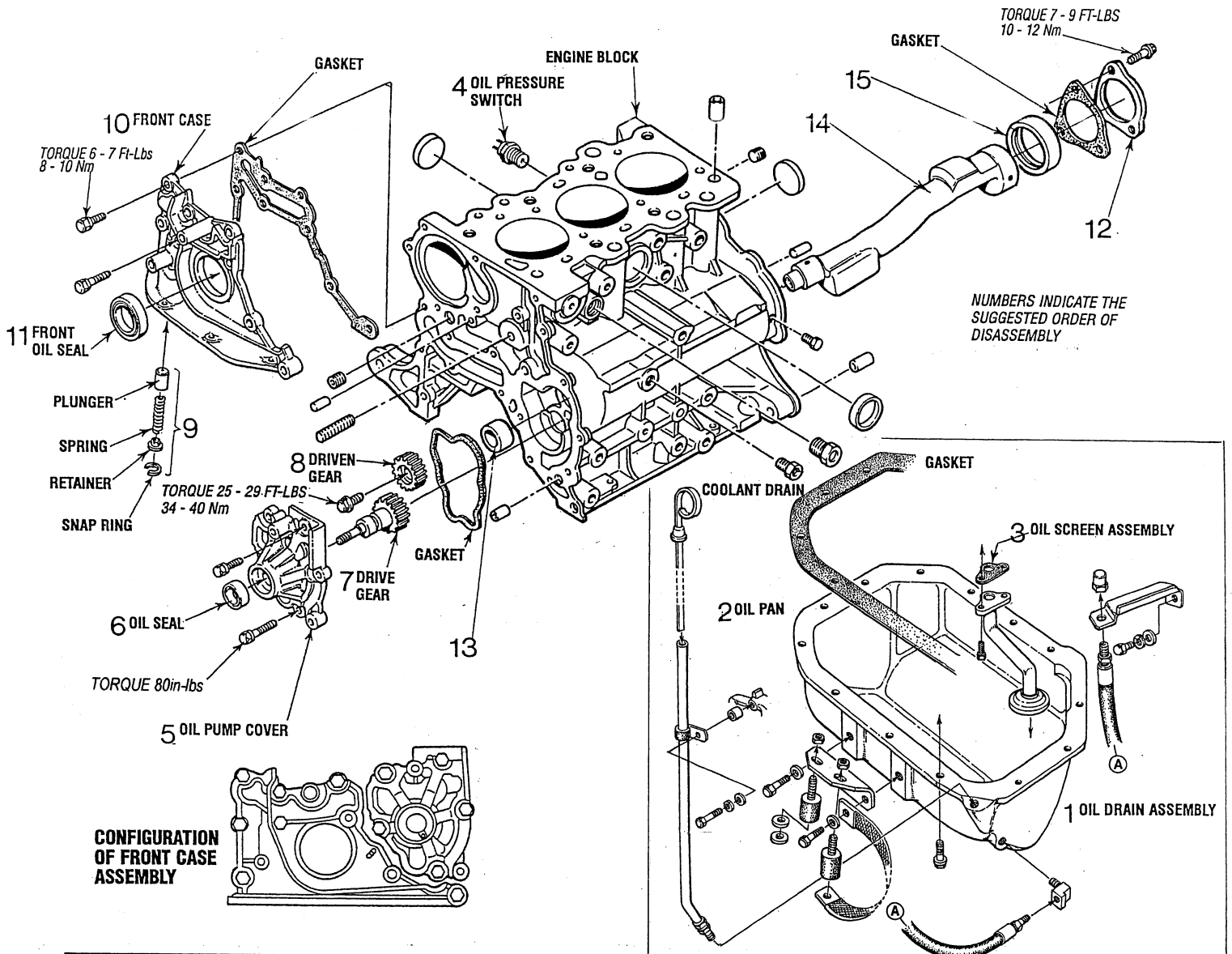

## OIL PAN REMOVAL

Remove the oil drain hose assembly. Remove the oil pan bolts and then use the special tool to break the pan seal.

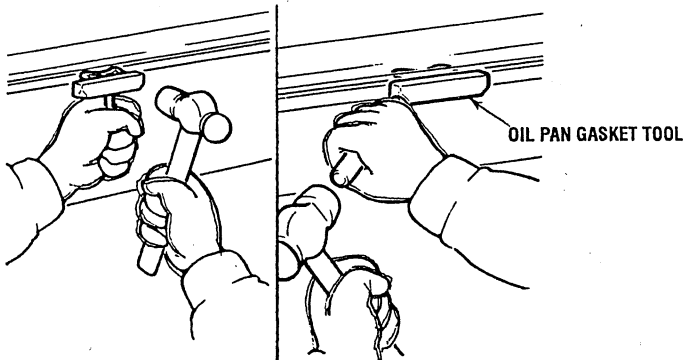

## COUNTERBALANCE SHAFT REMOVAL

1. Remove the plug on the cylinder block and insert an 0.32in (8mm) rod into the hole to lock the counterbalance shaft.

2. Remove the oil pump cover and gasket. Discard the gasket.
3. Remove the oil pump driven gear tightening flange bolts to release the counterbalance shaft.
4. Remove the counterbalance shaft. Drive it from the front.

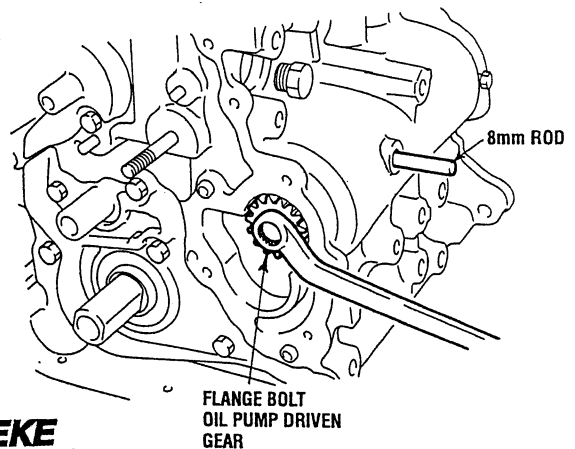

# FRONT CASE / COUNTERBALANCE SHAFT AND OIL PUMP

- Using a special tool drive the counterbalance shaft front bearing from the cylinder block.

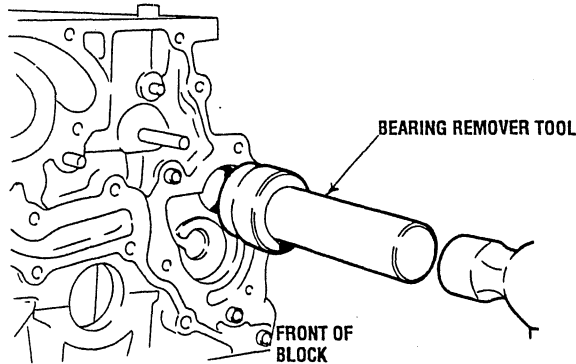

- Use the same tool and drive the counterbalance shaft rear bearing from the cylinder block.

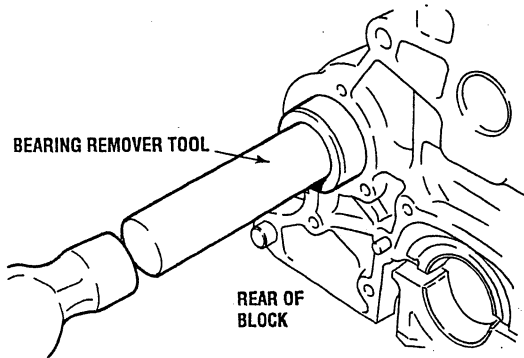

## OIL PUMP ASSEMBLY - INSPECTION

Fit the oil pump gear into the cylinder block, then, using a feeler gauge, check the clearance with the body at the points indicated in the diagram below.

### DRIVEN GEAR BODY CLEARANCE STANDARD

- A. 0.0161 - 0.0266in (0.410 - 0.675mm)
- B. 0.0051 - 0.0069in (0.130 - 0.175mm)

### DRIVE GEAR BODY CLEARANCE STANDARD

- C. 0.0173 - 0.0276in (0.44 - 0.70mm)
- D. 0.0059 - 0.077in (0.150 - 0.195mm)

DRIVEN GEAR SIDE CLEARANCE .0024 - 0.0047in (0.06 - 0.12mm)

DRIVE GEAR SIDE CLEARANCE 0.0027 - 0.0051in (0.07 - 0.13mm)

Using a straight edge, check the side clearance at the point indicated in the illustration with a feeler gauge.

There should be no uneven wear on the contact surfaces of the cylinder block or on the pump gear side of the pump cover.

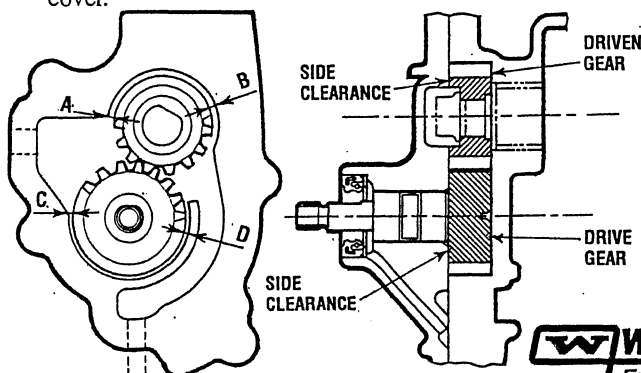

## FRONT CASE - INSPECTION

Check the front case for cracks or other damage also inspect the oil holes. If the oil holes are clogged, use compressed air or solvent to clean them out.

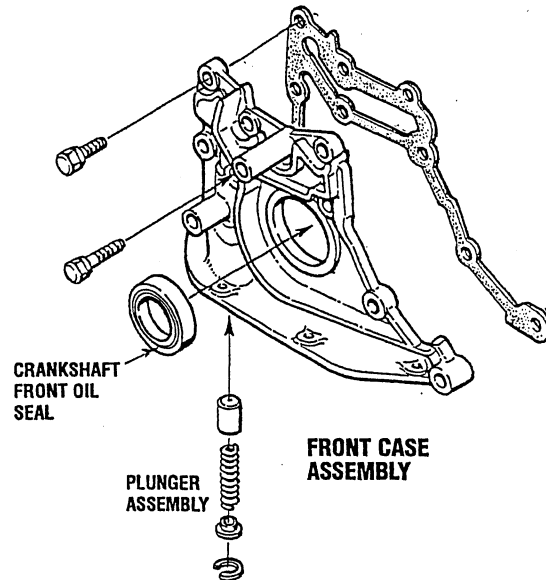

## CRANKSHAFT FRONT OIL SEAL - INSPECTION

Check the oil seal for wear and damage. Inspect the oil seal lip for hardening. If there any signs of wear, replace the seal.

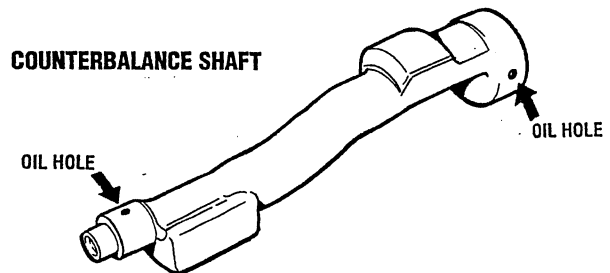

## COUNTERBALANCE SHAFT - INSPECTION

Inspect the oil holes for clogging and clean if necessary. Inspect the shaft journal for seizure, damage and its contact with the bearing. Check the counterbalance shaft oil clearance. Replace the counterbalance shaft if it fails to meet the standards.

### COUNTERBALANCE SHAFT STANDARDS

Front Journal Diameter	0.7869 - 0.7874in (19.987 - 20.000mm)
Rear Journal Diameter	1.7317 - 1.7322in (43.984 - 44.000mm)
Front Journal Oil Clearance	0.0014 - 0.0027in (0.035 - 0.068mm)
Rear Journal Oil Clearance	0.0014 - 0.0028in (0.035 - 0.071mm)

# FRONT CASE / COUNTERBALANCE SHAFT AND OIL PUMP

## INSTALLATION

### Counterbalance Rear Bearing

1. Install the special tool guide pins (bearing Installer) in the tapered hole of the cylinder block as shown.

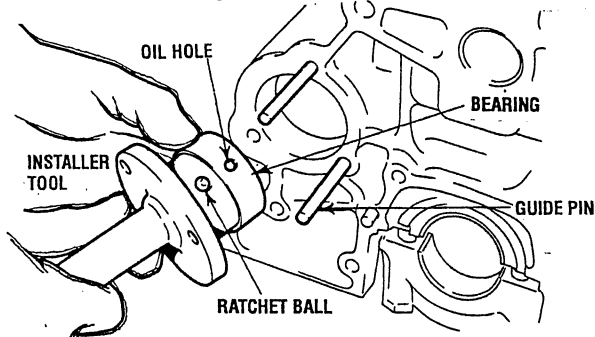

2. Mate the ratchet ball of the bearing in the oil hole of the rear bearing and install the bearing in the bearing installer.
3. Apply clean engine oil to the outer circumference of the bearing and the bearing hole in the cylinder block.
4. Insert the installer by mating it with the guide pins and press-in the bearing.

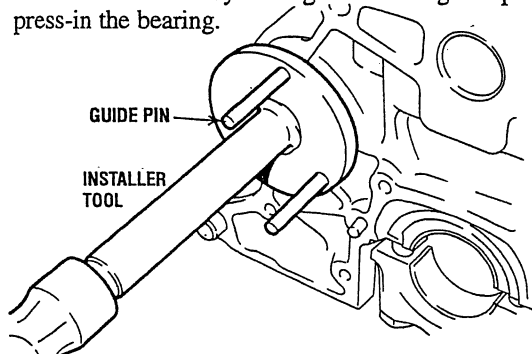

### Counterbalance Front Bearing

1. Apply engine oil to the bearing outer circumference and the bearing hole in the cylinder block.
2. Press-in the front bearing using the installer tool.

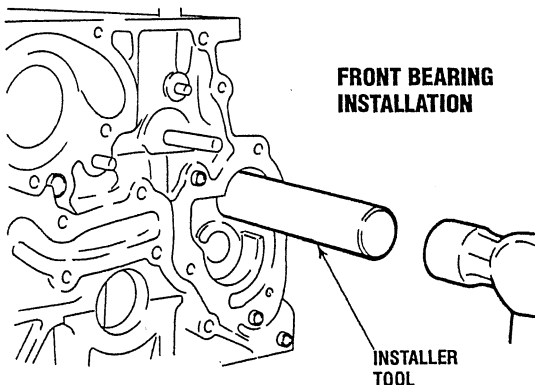

### Crankshaft Oil Seal

1. Apply oil to the crankshaft front oil seal lip inner circumference, and using the special tool, knock the oil seal into the front case.

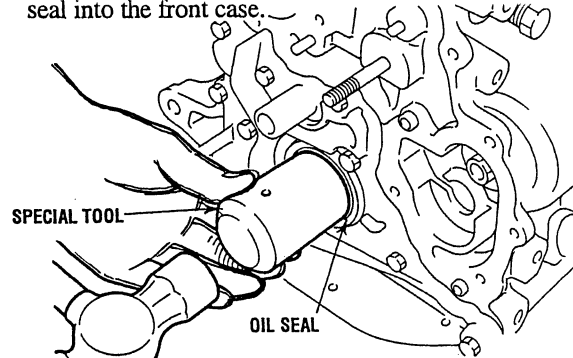

### Front Case Assembly

Install the front case assembly through the gasket and tighten the bolts to the specified torque.

**FRONT CASE BOLTS TORQUE** 6 - 7ft.lbs. (8 - 10 Nm)

There are two different length front case bolts. Make certain they are positioned properly. See the diagram.

**NOTE:** When installing the front case assembly, apply oil to the inner circumference of the oil seal lip. When installing the front case assembly take care not to damage the oil seal lip on the stepped up portion of the front end of the crankshaft.

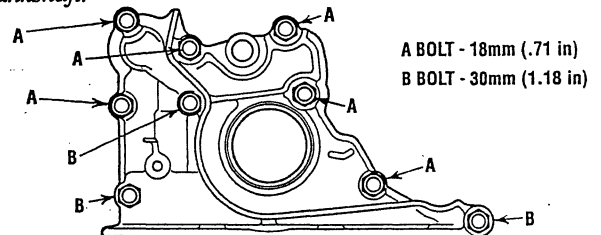

### Oil Pump Driven Gear

1. Apply an ample amount of clean engine oil to the oil pump driven gear and insert it so that the timing mark is positioned as shown.
2. Using the same hole on the side of the cylinder block, reinsert the 8mm rod to lock the counterbalance shaft. Then tighten the flange bolt to the specified torque.

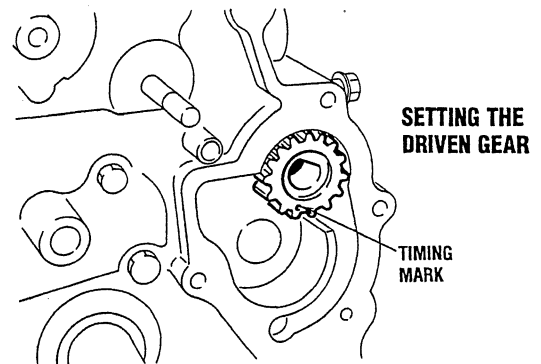

**DRIVEN GEAR FLANGE BOLT TORQUE**

25 - 29ft.lbs. (34 - 40Nm)



# FRONT CASE AND OIL PUMP

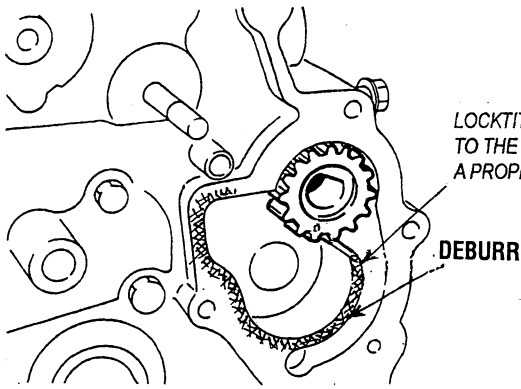

LOCKTITE #518 MUST BE APPLIED TO THE SHADED AREA TO ENSURE A PROPER SEAL

DEBURR

**NOTE:** Deburr this edge area as shown. Clean off all metal from the deburring process and clean with a cleaning agent. Wipe dry with a clean cloth and use compressed air to blow dry. The block surface and oil pump cover must be clean and free of oil.

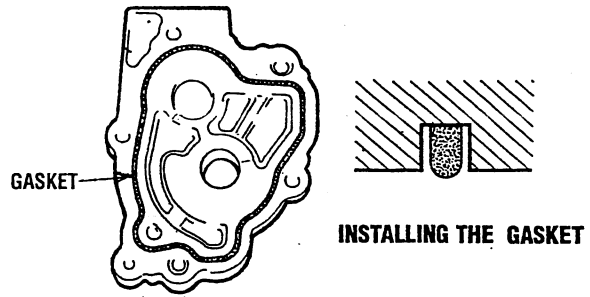

## Oil Pump Cover

Re-install the pump cover. Press or lightly tap the cover onto the alignment sleeves. The two long bolts go where the sleeves are - install these bolts first. Install the rest of the bolts in a criss-cross pattern. Torque the oil pump cover bolts to 80 inch-lbs.

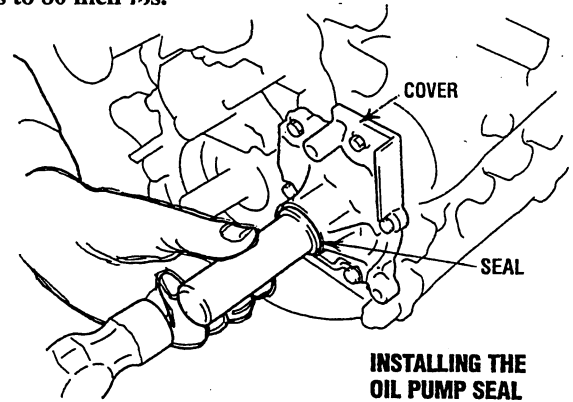

## Oil Pump Seal

Press the seal into the oil pump cover flush with the surface using the seal installer tool.

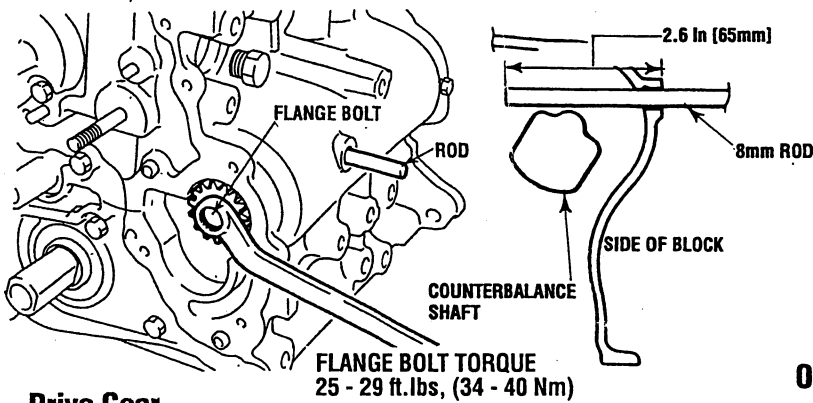

## Drive Gear

Align the timing marks and install the oil pump drive gear to the cylinder block.

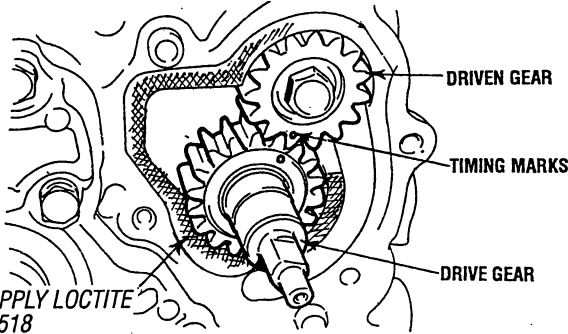

## Oil Pump Block Surface

Apply a very small bead of LOCTITE #518 to the engine block surface as shown. Spread it into a thin, even layer on the surface. Remove any excess.

## Oil Pump Cover Gasket

Fit a new oil pump cover gasket into the groove in the oil pump cover. The flat side of the gasket is positioned against the pump cover.

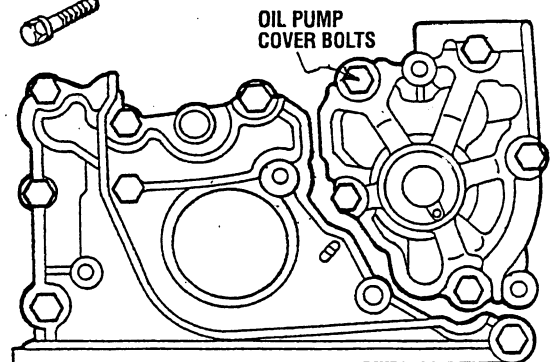
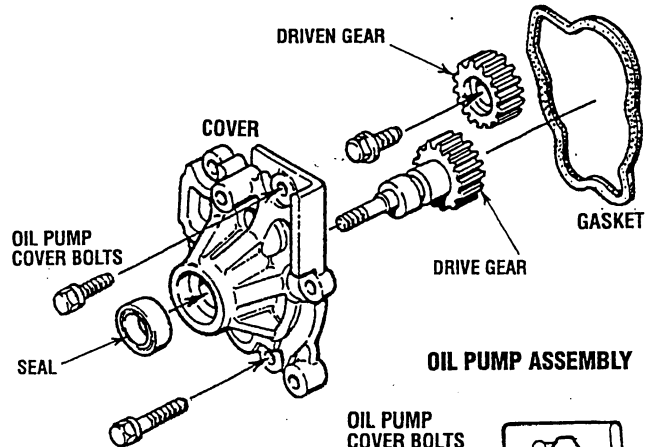

FRONT CASE CONFIGURATION

# CRANKSHAFT / BEARINGS AND OIL SEAL

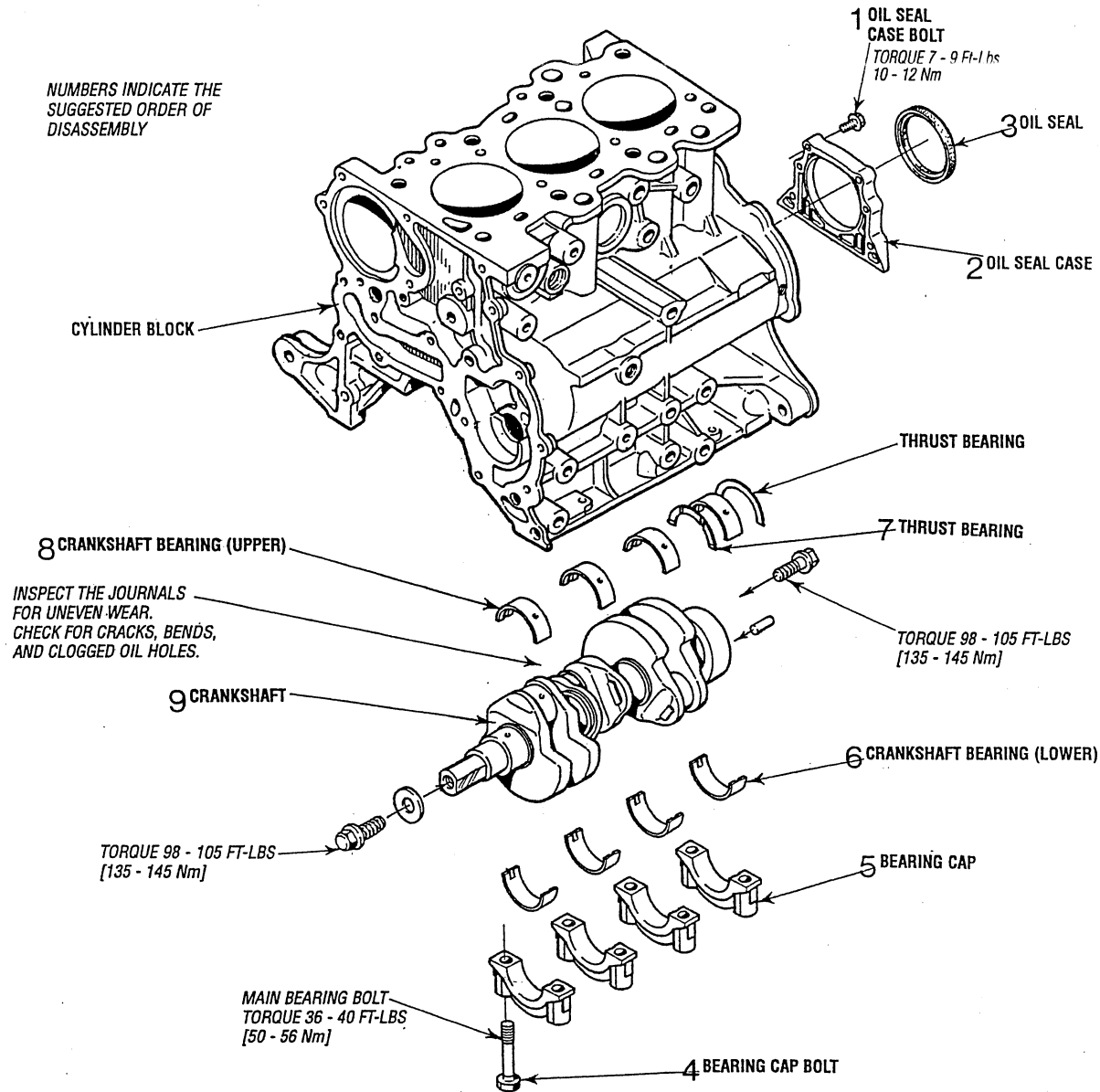

## CRANKSHAFT INSPECTION

1. Check the journals and pins for damage, seizure and cracks. Check the journals contact surface for uneven wear and replace if badly damaged.
2. Measure the outside diameter of the journal and the inside diameter of the main bearing. If the clearance (oil clearance) exceeds the limit, replace the main bearing and also the crankshaft, if necessary. Otherwise, fabricate an undersized crankshaft and replace the main bearing with an undersized one.

Standard  
0.0008 - 0.0018in (0.021 - 0.045mm)

Limit  
.004in (0.1mm)

3. When grinding the crankshaft to under-size, take note of the "R" dimensions of the fillets of the journal and pin area.

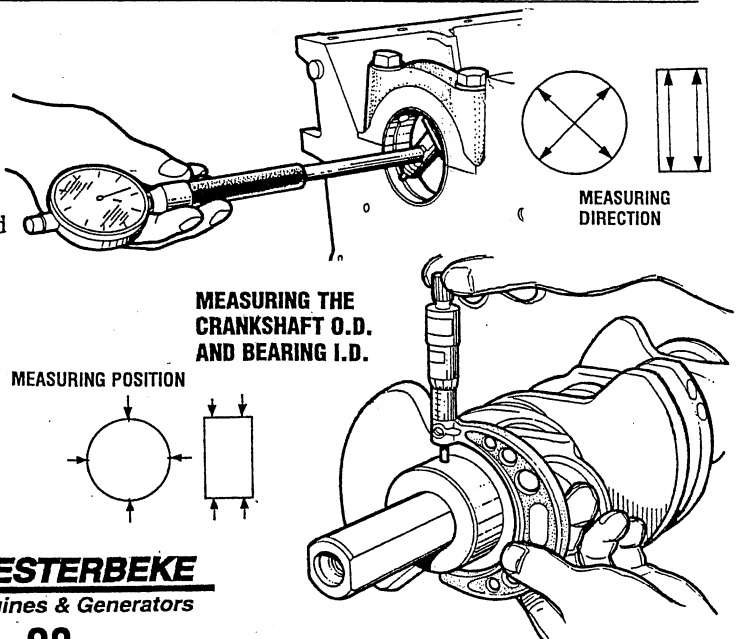

# CRANKSHAFT, BEARING AND OIL SEAL

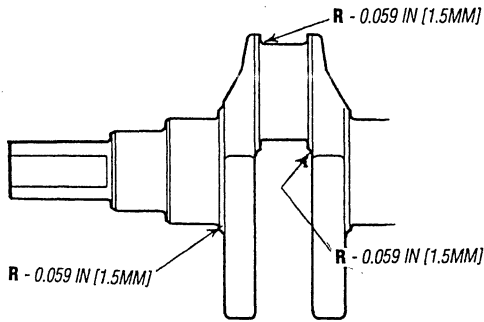

## CRANKSHAFT BEARINGS SPECIFICATIONS

### Upper and Lower

When the bearings are to be replaced, select the correct ones and install them in positions according to the identification marks stamped on the crankshaft and the top surface of the cylinder block.

#### CRANKSHAFT JOURNAL DIAMETER

Identification Marks	Journal Diameter
1	1.5746 - 1.5748 in (39.994 - 40.000mm)
2	1.5743 - 1.5746 in (39.988 - 39.994mm)
3	1.5741 - 1.5743 in (39.982 - 39.988mm)

## MEASURE THE CRANKSHAFT OIL CLEARANCE

The crankshaft oil measured by using a plastic gauge as follows:

1. The oil and grease and other foreign matters form the crankshaft journal and bearing inner surface.
2. Install the crankshaft.
3. Cut the plastic gauge to the same length as the width of the bearing and place it on the journal in parallel with its axis.
4. Gently place the main bearing cap over it and tighten the bolts to the specified torque.
5. Remove the bolts and gently remove the main bearing cap. Measure the width of the smashed plastic gauge (at its widest section) by using the scale printed on the plastic gauge.

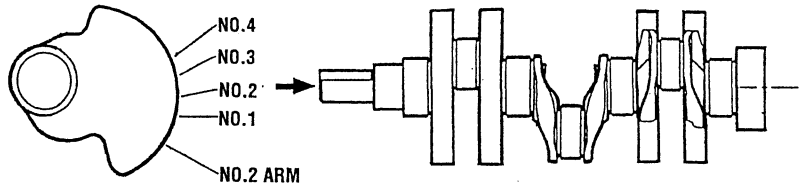
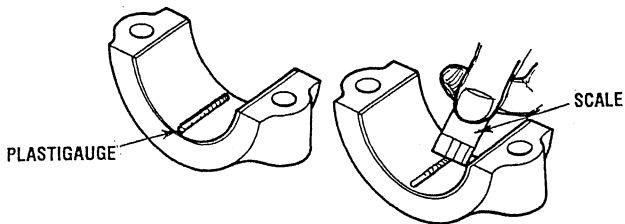
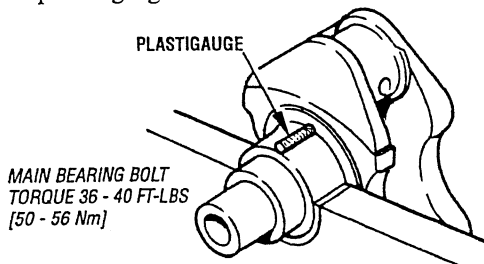

#### CRANKSHAFT BEARING THICKNESS

Identification Colors	Bearing Thickness
brown	0.0783 - 0.0784 in (1.988 - 1.991mm)
—	0.0784 - 0.0785 in (1.991 - 1.994mm)
blue	0.0785 - 0.0786 in (1.994 - 1.997mm)
yellow	0.0786 - 0.0787 in (1.997 - 2.000mm)
green	0.0787 - 0.0789 in (2.000 - 2.003mm)

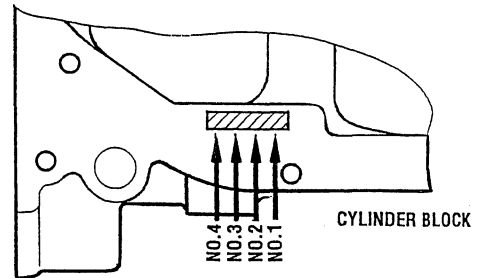

#### CYLINDER BLOCK BEARING DIAMETER

Identification Marks	Bearing Inner Diameter
O	1.7323 - 1.7325 in (44.000 - 44.006mm)
I	1.7325 - 1.7328 in (44.006 - 44.012mm)
II	1.7328 - 1.7330 in (44.012 - 44.018mm)

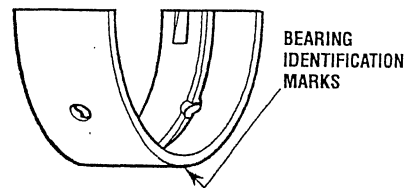

## INSPECTING THE CRANKSHAFT REAR OIL SEAL

1. Inspect the oil clearance lip for wear or damage. Check the rubber portion for deterioration and hardening. Replace the seal if at all suspect.
2. Check the oil case for cracks and damage. If here is damage, replace the case.

#### CRANKSHAFT BEARING SELECTION CHART

Crankshaft Journal Identification Marks	Crankshaft Bearing Identification Marks	Cylinder Block Bearing Identification Marks
1	brown	O
	—	I
	blue	II
2	—	O
	blue	I
	yellow	II
3	blue	O
	yellow	I
	green	II

# CRANKSHAFT/ BEARING AND OIL SEAL

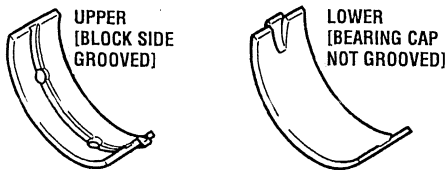

**CRANKSHAFT BEARINGS**

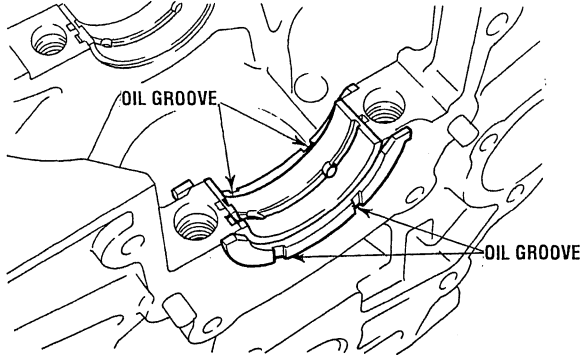

## INSTALLING THE THRUST BEARINGS

1. Apply a coat of oil to the thrust bearing and install so that the oil groove faces outward as illustrated.

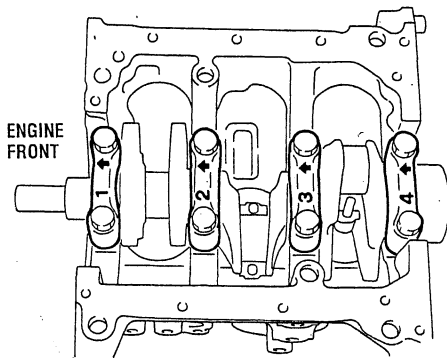

2. Install the bearing cap paying careful attention to the cap number and the arrow mark. Apply oil to the bolt threads.

3. Tighten the bearing cap to the specified torque.

**BEARING CAP BOLT TORQUE** 36 - 40 ft-lbs (50 - 55Nm)

## MEASURING END PLAY

Push the crankshaft to the rear. Then, insert a feeler gauge in the gap between the crankshaft journal side surface and the thrust bearing end surface to measure the end play.

**CRANKSHAFT END PLAY:** 0.0020 - 0.0098in (0.05 - 0.25mm)

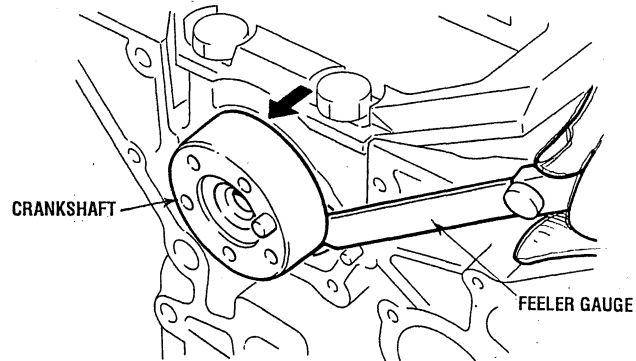

## CRANKSHAFT REAR OIL SEAL

1. Apply engine oil to the rear cover and to the oil seal.
2. Press the oil seal into the seal case using the special tool.

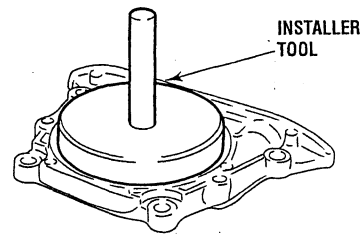

3. Install the oil seal case into the cylinder block through the gasket. (If there is no gasket, coat with sealant.) The entire circumference of the oil seal lip should be coated with clean engine oil.

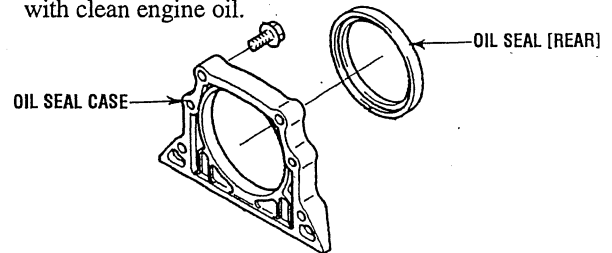

**NOTE:** Make certain the lips of the oil seal are not turned up.

**OIL CASE BOLT TORQUE:** 7 - 9 Ft-lbs (10 - 12Nm)

# CYLINDER BLOCK INSPECTION AND PISTON CLEARANCE

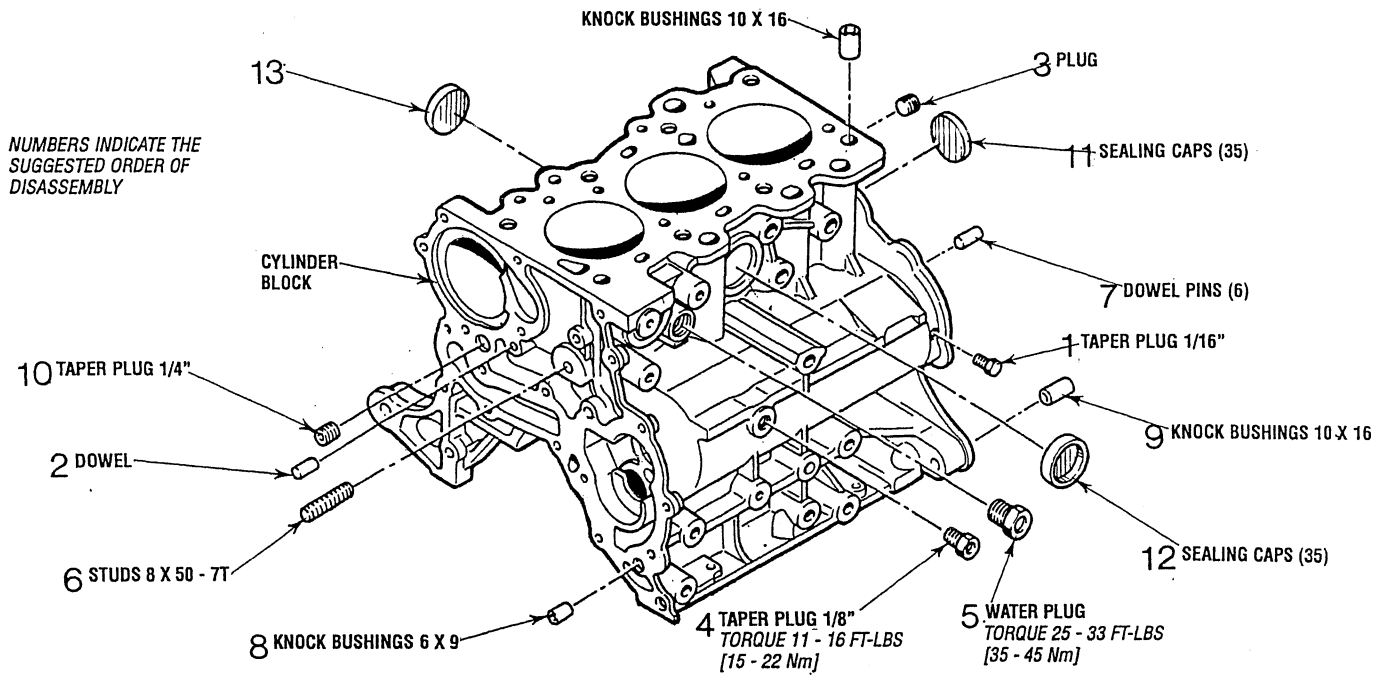

## CYLINDER BLOCK INSPECTION

1. Before inspecting, clean the cylinder block to ensure that the water and oil holes are not plugged. If clogged, clear with compressed air.
2. Check for cracks and damage. Use a flaw detecting compound as needed. Replace the block if defective.
3. Inspect the mating surface. Using a straight edge and feeler gauge measure the flatness of the top surface. Grind or replace if the limit is exceeded.

FLATNESS STANDARD VALUE: 0.0020 in (0.05 mm)  
LIMIT: 0.004 in (0.1 mm)

4. Inspect the cylinder bore. Using a cylinder gauge, measure the bore at six places (as shown in the diagram). Calculate the difference between the max. and min. values. If worn or damaged, rebores or replace the cylinder.

CYLINDRICITY STANDARD VALUE: 0.004in (0.01mm) or less  
CYLINDRICITY BORE: 2.5591 - 2.5602in (65.00 - 65.03mm)  
LIMIT CYLINDRICITY: 0.0008in (0.02mm)

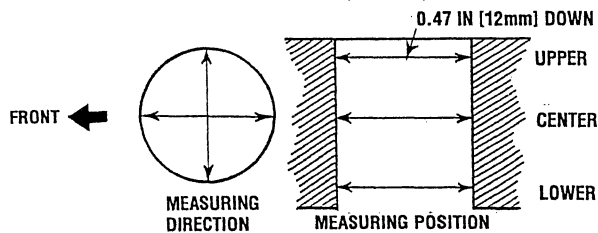

## CHECKING THE PISTON CLEARANCE

Calculate the difference between the minimum cylinder bore in the thrust direction and the piston outer diameter shown in the illustration. If the difference exceeds the specified range, replace the piston or cylinder block, or rebores the cylinder.

PISTON TO CYLINDER CLEARANCE STANDARD:  
0.0008 - 0.0016 in (0.0 - 0.04 mm)

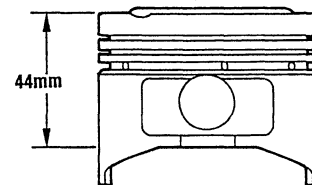

## BORING THE CYLINDER

1. Select an oversize piston based on the cylinder with the maximum bore and maximum damage depth.
2. Using the outer diameter (at the specified measurement point) of the selected oversize piston, calculate the boring dimension.

Boring dimension = (Piston O.D.) + (piston clearance) - (honing margin : 0.0008in (0.02mm))

OVERSIZE PISTON OUTSIDE DIAMETER AND CYLINDER (INNER DIAMETER FINISH DIMENSION (REF))

Size	Mark	Piston Dia.	Cylinder Inner Dia.
0.25 O.S.	25	2.5677 - 2.5689in (65.22 - 65.25mm)	2.5693 - 2.5697in (65.26 - 65.27mm)
0.50 O.S.	50	2.5776 - 2.5787in (65.47 - 65.50mm)	2.5791 - 2.5795in (65.51 - 65.52mm)
0.75 O.S.	75	2.5874 - 2.5886in (65.72 - 65.75mm)	2.5890 - 2.5894in (65.76 - 65.77mm)
1.00 O.S.	100	2.5972 - 2.5984in (65.97 - 66.00mm)	2.5988 - 2.5992in (66.01 - 66.02mm)

3. Bore the cylinder to obtain the calculated dimensions.
- 4.hone to finish the cylinder inner diameter.
5. Check again for cylindricity and piston clearance.

# SERVICE DATA / STANDARDS AND LIMITS - BCG ENGINE/GENERATOR

Component	Specified Value / Standard inches(mm)	Repair Limit inches(mm)
<b>FRONT CASE/COUNTERBALANCE SHAFT</b>		
Oil Pump Side Clearance		
Driven Gear.....	0.0024-0.0047 (0.06-0.12)	
Drive Gear.....	0.0027-0.0051 (0.07-0.13)	
Counterbalance Shaft Front Journal Diameter		
.....	0.7869-0.7874 (19.987-20.000)	
Counterbalance Shaft Rear Journal Diameter		
.....	1.7317-1.7322 (43.984-44.000)	
Counterbalance Shaft Front Journal Oil Clearance		
.....	0.0014 - 0.0027 (0.035 - 0.068)	
Counterbalance Shaft Rear Journal Oil Clearance		
.....	0.0014 - 0.0028 (0.035 - 0.071)	

Component	Specified Value / Standard inches(mm)	Repair Limit inches(mm)
<b>CYLINDER BLOCK</b>		
Cylinder Bore	2.5591-2.5602 (65.00-65.03)	
Out-of-Roundness and Taper of Cylinder Bore	0.0004 (less than 0.01)	
Gasket Surface Flatness	0.0020 (less than 0.05)	0.0039 (0.1)

Component	Specified Value / Standard inches(mm)	Repair Limit inches(mm)
<b>CYLINDER HEAD</b>		
Flatness of Gasket Surface	less than 0.0019 (0.05)	0.0079 (0.2)
Overall Height.....	4.287-4.295 (108.9-109.1)	
Cylinder Head oversize rework dimension of valve seat hole		
Intake 0.3 O.S.....	1.2323 - 1.2333 (31.300 - 31.325)	
Intake 0.6 O.S.....	1.2441 - 1.2451 (31.600 - 31.625)	
Exhaust 0.3 O.S.....	1.1535 - 1.1544 (29.300 - 29.321)	
Exhaust 0.6 O.S.....	1.1653 - 1.1662 (29.600 - 29.621)	
Cylinder Head rework of valve guide hole (both intake and exhaust)		
0.05 O.S.....	0.4744 - 0.4751 (12.050 - 12.068)	
0.25 O.S.....	0.4823 - 0.4830 (12.250 - 12.268)	
0.50 O.S.....	0.4921 - 0.4928 (12.500 - 12.518)	
Intake Valve Seat Angle.....	45°	
Exhaust Valve Seat Angle.....	30°	
Intake Valve Seat Width.....	0.079 (2.0)	0.004 (0.1)
Exhaust Valve Seat Width.....	0.079 (2.0)	0.004 (0.1)
Valve Clearance.....		
Exhaust.....	0.012 (0.30)	
Intake.....	0.008 (0.20)	
Valve Head Thickness (margin)		
(Intake).....	0.039 (1.0)	0.020 (.5)
(Exhaust).....	0.051 (1.3)	0.031 (.8)
Valve Length		
(Intake).....	3.960 (100.6)	
(Exhaust).....	3.968 (100.8)	
Valve Stem O.D.		
Intake.....	0.2585 - 0.2591 (6.565 - 6.580)	
Exhaust.....	0.2571 - 0.2579 (6.530 - 6.550)	
Stem to Guide Clearance		
Intake.....	0.0008 - 0.0020 (0.02 - 0.05)	0.0039 (0.10)
Exhaust.....	0.0020 - 0.0033 (0.0050 - 0.0085)	0.0059 (0.15)
Valve Guide Length		
(Intake).....	1.73 (44)	
(Exhaust).....	1.949 (49.5)	

Component	Specified Value / Standard inches(mm)	Repair Limit inches(mm)
<b>VALVES</b>		
Valve Guide Service Size	0.05, 0.25, 0.50 oversize	
Valve Seat Width of Seat Contact.....	0.035-.051 (0.9-1.3)	
Valve Seat Angle.....	30°/44°/65°	
Valve Seat Sink.....	0.008 (0.2)	
Valve Spring Free Length.....	1.823 (46.3)	1.783 (45.3)
Valve Spring Load/Installed Height lbs./in (N/mm).....	46/1.48 (210/37.7)	
Squareness.....	less than 2°	4°

Component	Specified Value / Standard inches(mm)	Repair Limit inches(mm)
<b>TIMING BELT</b>		
Seal Line Clearance.....	47 (12)	

Component	Specified Value / Standard inches(mm)	Repair Limit inches(mm)
<b>ROCKER ARM/CAMSHAFT</b>		
Camshaft Height		
No. 1 (Intake).....	1.3815 (35.09)	1.3618 (34.59)
No. 2 (Intake).....	1.3807 (35.07)	1.3610 (34.57)
No. 3 (Intake).....	1.3803 (35.06)	1.3606 (34.56)
No. 1 (Exhaust).....	1.3839 (35.15)	1.3642 (34.65)
No. 2 (Exhaust).....	1.3831 (35.13)	1.3634 (34.63)
No. 3 (Exhaust).....	1.3854 (35.190)	1.3657 (34.69)
Camshaft Journal Diameter.....	1.6118-1.6124(40.940-40.955)	
Bearing Oil Clearance.....	0.0018-0.0033 (0.045-0.085)	
End Play.....	0.0024-.0055 (.06-.14)	118 (.03)
Rocker Shaft Length.....	9.134 (232)	
Rocker Arm Shaft		
Outer Diameter.....	0.6687 - 0.6692 (16.985 - 16.998)	
Clearance.....	0.0005 - 0.0017 (0.012 - 0.043)	0.004 (0.1)

Component	Specified Value / Standard inches(mm)	Repair Limit inches(mm)
<b>PISTON AND CONNECTING ROD</b>		
Piston Outer Diameter.....	2.5579-2.5591 (64.97-65.00)	
Piston to Cylinder Clearance		
.....	0.0008 - 0.0016 (0.02 - 0.04)	
Piston Ring Groove Width		
No.1.....	0.0480 - 0.0488 (1.22 - 1.24)	
No.2.....	0.0476 - 0.0484 (1.21 - 1.23)	
Oil.....	0.1108 - 0.1116 (2.815 - 2.835)	
Piston Service Size.....	0.25, 0.50, 0.75, 1.00 OS	
Piston Ring End Gap		
No.1.....	0.0059 - 0.0118 (0.15 - 0.30)	0.0315 (0.8)
No.2.....	0.0138 - 0.0197 (0.35 - 0.50)	0.0315 (0.8)
Oil.....	0.008 - 0.028 (0.2 - 0.7)	0.0394 (1.0)
Piston Side Clearance		
No.1.....	0.0012 - 0.0028 (0.03 - 0.07)	0.0047 (0.12)
No.2.....	0.0008 - 0.0024 (0.02 - 0.06)	0.0039 (0.10)
Piston Pin O.D.....	0.6300 - 0.6302 (16.001 - 16.007)	
Piston Pin Press-in Load lbs(N)		
.....	1102 - 3307 (5000 - 15000)	

# SERVICE DATA / STANDARDS AND LIMITS - BCG ENGINE/GENERATOR

Component	Specified Value / Standard inches(mm)	Repair Limit inches(mm)
<b>PISTON AND CONNECTING ROD</b>		
Piston Pin Press-in temperature	.....ordinary temperature	
Connecting Rod Center length	.....4.0138 4.0178 (101.95 - 102.05)	
Parallelism between Big End and Small End	.....0.004 (0.05)	
Connecting Rod Twist.....	0.004 (0.1)	
Connecting Rod Big End to Crankshaft Side Clearance	.....0.0039 - 0.0098 (0.10 - 0.25) .....	0.16 (0.4)

Component	Specified Value / Standard inches(mm)	Repair Limit inches(mm)
<b>CRANKSHAFT, BEARING</b>		
Crankshaft End Play.....	0.0020 - 0.0098 (0.05 - 0.25) .....	
Crankshaft Journal O.D. ...	1.5740 - 1.5748 (39.98 - 40.0)	
Crankshaft Pin O.D. ....	1.4165 - 1.4173 (35.98 - 36.00)	
Cylindricity of Journal and Pin	.....Less than 0.0002 (0.005)	
Concentricity of Journal and Pin	.....Less than 0.0006 (0.015)	
Oil Clearance of Journal	.....0.0008 - 0.0018 (0.021 - 0.045) .....	0.0039 (0.1)
Oil Clearance of Pin .....	0.0009 - 0.0020 (0.022 - 0.052)	
Undersize rework dimension of Journal		
0.25 U.S. ....	1.5644 - 1.5650 (39.735 - 39.750)	
0.50 U.S. ....	1.5545 - 1.5551 (39.485 - 39.500)	
0.75 U.S. ....	1.5447 - 1.54539 (39.235 - 39.250)	
Undersize rework of dimension of pin		
0.25 U.S. ....	1.4069 - 1.4075 (35.735 - 39.750)	
0.50 U.S. ....	1.3970 - 1.3976 (35.485 - 35.500)	
0.75 U.S. ....	1.3872 - 1.3878 (35.235 - 35.250)	

# ENGINE HARDWARE TORQUES

Timing Belt	Nm	ft. lbs.
Crankshaft bolt (front)	135-145	98-105
Timing belt cover bolts	10-12	7-9
Camshaft sprocket bolts	80-100	58-72
Oil pump sprocket nuts	50-57	36-41
Timing tensioner nuts	22-30	16-22
Timing belt rear cover bolts	10-12	7-9
<b>Rocker Arms and Rocker Shaft</b>		
Rocker cover shaft	29-35	21-25
Camshaft thrust plate bolt	10-12	7-9
Rocker arm adjust nut	8-10	6-7
<b>Cylinder Head, Valve</b>		
Cylinder head bolt (cold engine)	60-70	43-51
Spark plug	15.2	10.8
Rocket cover	12-13	9-10
<b>Miscellaneous</b>		
Coolant temperature sender	12-18	9-13
Coolant temperature switch	12-18	9-13
Generator mounts	34-47	23-34
Intake/Exhaust manifold	16-23	12-17
Thermostat housing	8-11	6-8
Carburetor to manifold	16-23	12-17
Flywheel bolts	135-145	98-105

Front Case, Counterbalance Shaft	Nm	ft. lbs.
Front case bolts	8-10	6-7
Oil pump cover bolts	8-10	6-7
Oil pan bolts	10-12	7-9
Oil drain plug	35-45	25-33
Oil screen bolts	15-22	11-16
Oil pump driven gear bolt	34-40	25-29
Rear cover bolts	10-12	7-9
<b>Piston and Connecting Rod</b>		
Connecting rod cap nut	15 + 90° turn	11 + 90° turn
<b>Crankshaft, Bearing</b>		
Oil seal case bolts	10-12	7-9
Bearing cap bolts	50-55	36-40
<b>Cylinder Block</b>		
Taper plug 1/16	8-12	6-9
Taper plug 1/8	15-22	11-16
Water drain plug	35-45	25-33
Taper plug 1/4 NPT	35-45	25-33
Oil pressure switch	12-18	9-13
Oil pressure sender	12-18	9-13
<b>Water Pump</b>		
Water pump	8-10	6-7



# SPECIAL TOOLS - ENGINE

**NOTE:** These special tools are available from your local Mitsubishi Automotive Dealer

**CAMSHAFT OIL SEAL INSTALLER**  
MD 999569

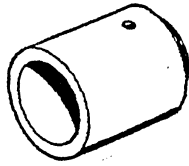

**VALVE STEM SEAL INSTALLER**  
MD 998302

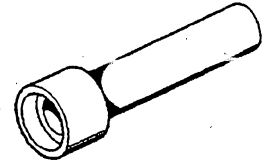

**PISTON PIN SETTING BASE**  
*Used to pull-out and press in the piston pin.*  
MD 999583

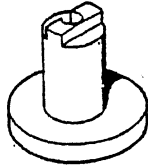

**OIL PAN GASKET CUTTER**  
*For removing the oil pan to break the oil pan seal.*  
MD 998727

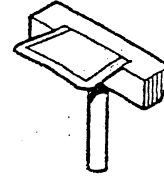

**CRANKSHAFT REAR OIL SEAL INSTALLER**  
MD 998376

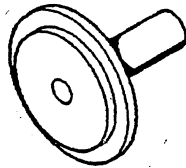

**BEARING REMOVER**  
*For pulling out the front and rear bearings (counterbalance shaft).*  
MD 999593

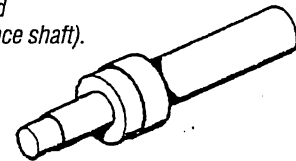

**PUSH ROD AND PIN SET GUIDE**  
*Used to pull-out and press in the piston pin.*  
MD 999584

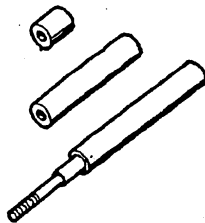

**FRONT BEARING INSTALLER**  
*(Counterbalance shaft).*  
MD 999591

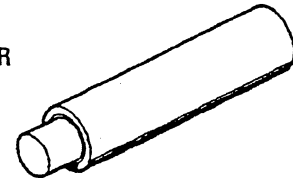

**PIN** *For supporting the sprocket when the camshaft sprocket is loosened or tightened.*  
MD 998715

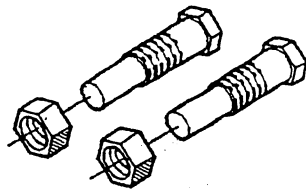

**INSTALLER FOR THE REAR OIL SEAL**  
*(Counterbalance shaft).*  
MD 999592

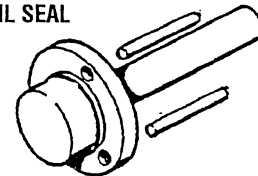

**END YOKE HOLDER**  
*For supporting the sprocket when the camshaft sprocket is loosened or tightened.*  
MD 990767

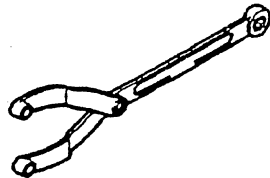

**CRANKSHAFT FRONT OIL SEAL INSTALLER**  
MD 999570

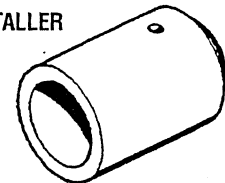

**VALVE SPRING COMPRESSOR**  
MD 999597

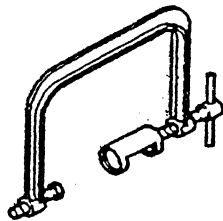

**OIL PUMP OIL SEAL INSTALLER**

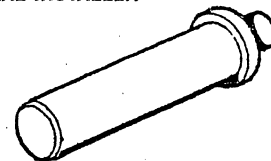

# EXHAUST MANIFOLD / HEAT EXCHANGER

## EXHAUST MANIFOLD

The exhaust manifold, which was disassembled from the cylinder head, should be inspected before reassembly.

1. Remove the exhaust elbow from the manifold. Scrape off and discard the old gasket. Inspect the exhaust elbow for corrosion and damage, replace if necessary.
2. If the exhaust elbow passes inspection, remove the high temperature sensor and clean and re-paint the elbow with WESTERBEKE heat resistant enamel.
3. Carefully inspect the exhaust manifold, remove the hose connections noting the location of each for proper alignment at reassembly. Clean the exterior and interior manifold. If the manifold can be reused, repaint with WESTERBEKE heat resistant enamel.

## ASSEMBLY

1. If the manifold was removed as an assembly and left intact, it can be replaced on the cylinder head in the reverse order of removal. Install a new gasket.  
**MANIFOLD MOUNTING BOLTS TORQUE 12 - 17 ft-lb (16 - 23 Nm)**
2. Attach the hose connections to the manifold and the exhaust elbow. Once the engine has been re-installed and running, carefully check these assemblies and hose connections for leaks.

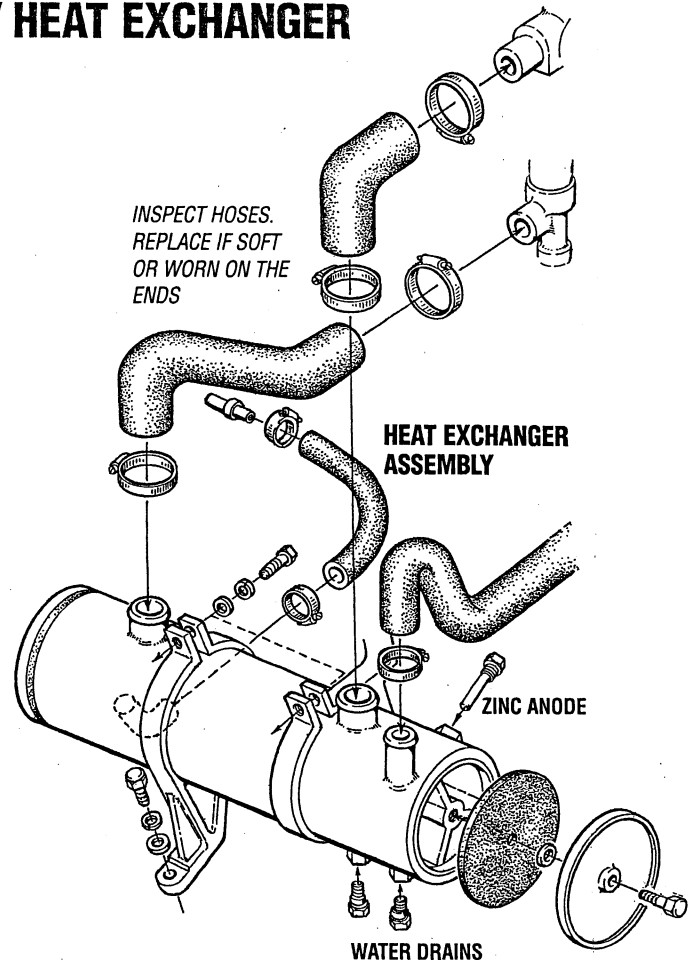
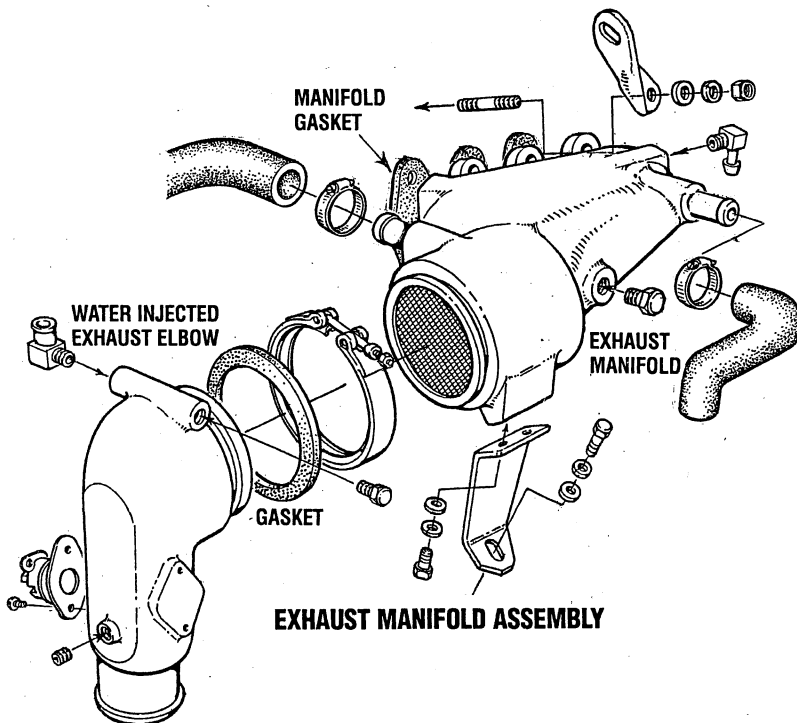

## HEAT EXCHANGER

The heat exchanger should be inspected and serviced during an engine overhaul.

1. Disconnect the hoses and remove the hose fittings, petcock, drain plugs and zinc anode. Also, remove the end fittings and gaskets.
2. Inspect the tube (casing) for wear and dents, if at all suspect replace the heat exchanger.
3. Clean out any zinc debris and pressure test the coolant and raw water passages.
4. When reassembling, install new gaskets and O-rings. Apply some lubricant to the new gaskets and to the petcocks and fittings as you install them.
5. Install a new zinc anode.

**NOTE:** All of the above can be accomplished by sending the heat exchanger to a heat exchanger/radiator service shop. They will also service transmission and engine oil coolers.

6. Repaint the assembled heat exchanger with WESTERBEKE heat resistant spray enamel!

## HEAT EXCHANGER ASSEMBLY

Reinstall the heat exchanger. Tighten down the holdown brackets and once the engine is running, check the heat exchanger and hose connections for leaks.

# COOLANT CIRCULATING PUMP

## REMOVING THE COOLANT PUMP

1. Loosen the belt guards thumbscrews and remove the engine's belt guard from its brackets at the front of the engine.
2. Ease the belt tension by releasing the raw water pump and remove the engine drive belt [on carburetor models it will be necessary to remove the governor belt].
3. Unscrew the five bolts that hold the pump to the engine and remove the coolant pump and its gasket. Note that the pulley is an integral part of the pump assembly.

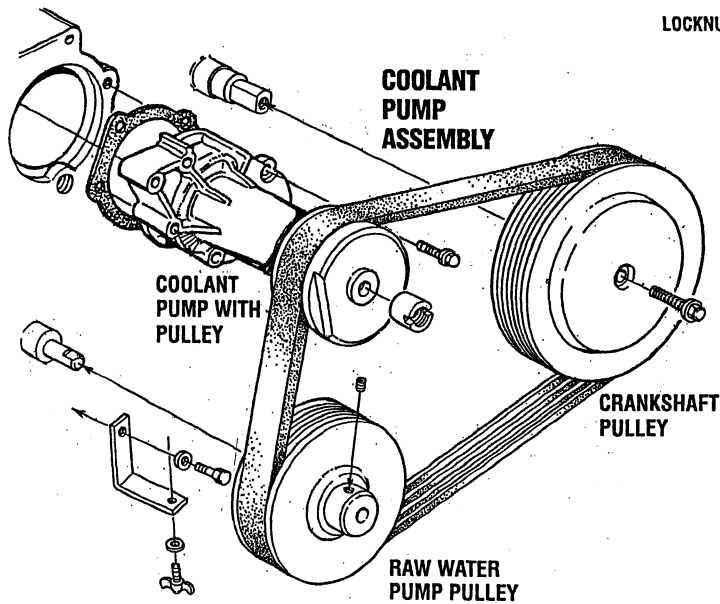

## INSPECTION

Carefully check the pump body and impeller for cracks and damage. Inspect the weep holes for signs of water leakage and rust that would indicate a faulty seal. The pulley should turn the shaft (and impeller) smoothly, without noise or sluggish rotation.

The pulley edges should be smooth and undamaged and the locknut should be drawn up tight.

## COOLANT PUMP

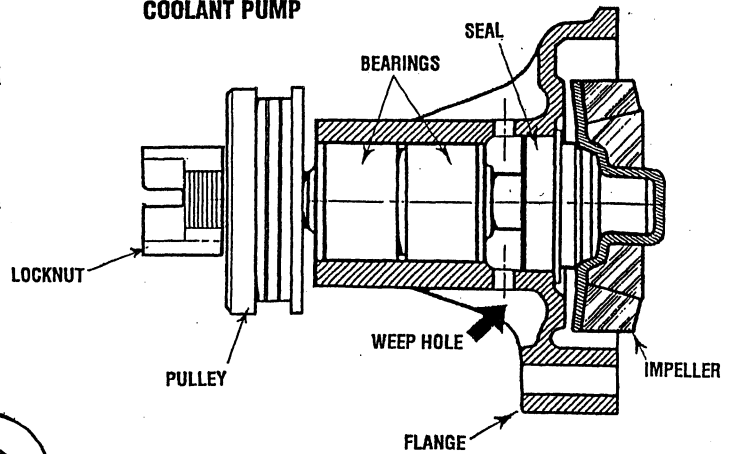

## REPAIR

If the pump does not pass inspection, replace the entire pump assembly which includes the pulley.

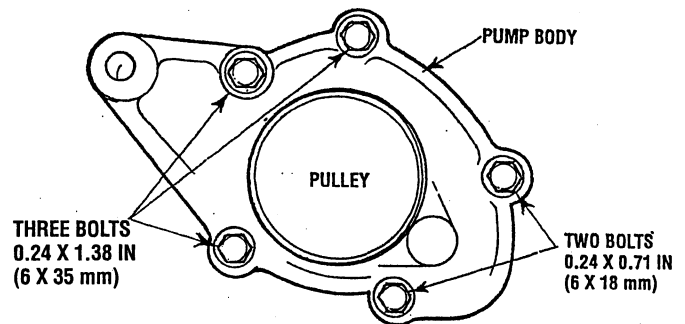

## INSTALLATION

When reinstalling the pump use a new gasket. There are five bolts in two sizes that fasten the pump in place, make certain they are positioned properly. See the diagram above. Use sealant when assembling the new gasket.

**CIRCULATING PUMP BOLT TORQUE 6 - 7 ft - lbs (8 - 10 Nm)**

# RAW WATER PUMP (PN.042026)

## PUMP OVERHAUL

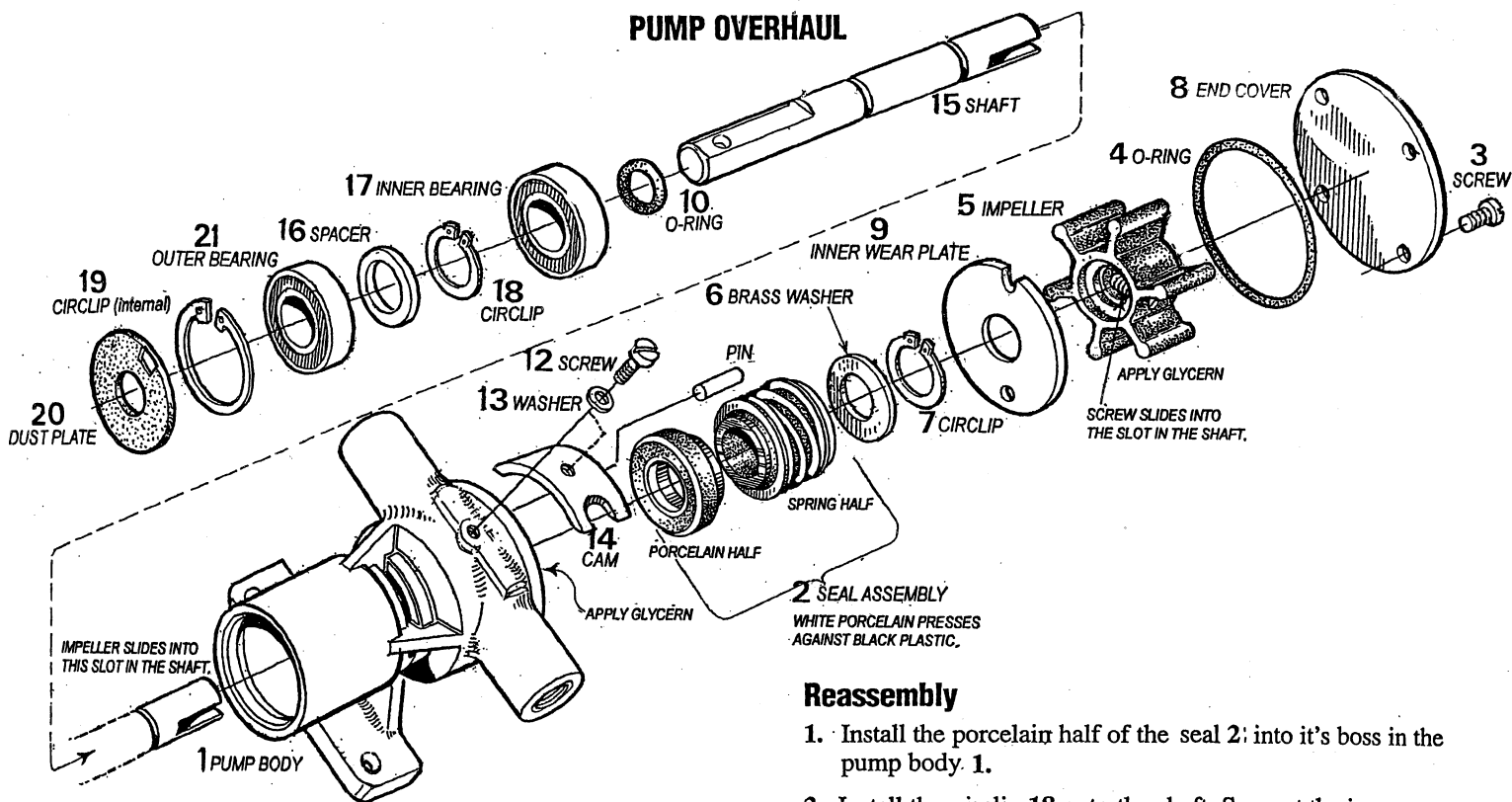

### Disassembly

The pump when removed from the engine, will have hose attachment nipples threaded into its inlet and outlet ports along with the drive pulley attached to the shaft of the pump. In most cases the hose nipples can be left in place. Note their positioning. Remove the drive pulley.

1. Remove the four cover plate screws 3 and the end cover 8 and "O" ring 4.
2. Remove the impeller 5 using a pair of pliers, grasp the impeller hub and pull it out of the pump with a twisting motion.
3. Remove the screw 12 and washer 13 that holds the cam in place. Remove the cam 14 and the inner wear plate 9.
4. Remove the brass circlip 7 and the brass holding washer 6 along with the spring half of seal 2.
5. Remove the dust plate 20 along with circlip 19.
6. Support the pump body on an appropriate surface and with a drift, push the shaft 15 with bearing assembly 17, 18, 16 and 17 out of the pump body 1.
7. Remove the "O" ring 10 from the shaft.
8. Support the outer bearing 17 and push the shaft out of the bearing.
9. Remove the spacer 16 and the circlip 18 from the shaft.
10. Support the inner bearing 17 and push the shaft out of the bearing.
11. Using a thin drift, knock the porcelain half of the seal 2 out of its boss in the pump body 1.

### Inspection

Inspect all parts. Review the components in the Overhaul Kit #046623 and proceed to re-assemble the pump.

### Reassembly

1. Install the porcelain half of the seal 2 into its boss in the pump body 1.
2. Install the circlip 18 onto the shaft. Support the inner bearing 17 and press the shaft into the bearing until it contacts the circlip.
3. Install the spacer 16 onto the shaft. Support the shaft and push the outer bearing 21 onto the shaft until it contacts the spacer.
4. Apply glycerin to the "O" ring 10 and install it on the shaft about 1/8" away from the inner bearing.
5. Support the pump body on an arbor press and push the shaft and bearing assembly into the pump body until the outer bearing just clears the boss for the circlip 19.
6. Install circlip 19 and push the shaft and bearing assembly so the outer bearing 17 just contacts the circlip 19. Rotate the shaft to ensure no binding.
7. Install the dust plate 20.
8. Apply glycerin to the inner surface of the 2<sup>nd</sup> half of the seal 2 and with a twisting motion install it over the shaft and slide it down until the plastic surface of the spring seal contacts to porcelain half. Install the spring seal brass washer 6 and secure it in place with the brass circlip 7.
9. Install the wear plate 9, cam 14 and secure the cam with screw 12 and sealing washer 13.
10. Apply glycerin to the surface of the impeller housing, inner surface of the cover plate 8 and sealing "O" ring 4. Fit the "O" ring into its recess in the pump housing.
11. With a twisting motion, install the impeller 5 into the pump so it mates properly with the slot in the shaft 15.
12. Install the drive pulley onto the shaft of the pump. Install the pump onto the engine. Check the pulley/belt alignment. Ensure the pulley is properly secured. Re-attach the raw water hose.

# CARBURETOR - LOW PROFILE

## CARBURETOR

The carburetor is a single barrel, side-draft type with a cleanable metal screen air intake filter/spark arrester.

### Air Screen

The air screen can easily be removed. Clean after the first 50 hours of operation and every 100 hours from then on. Clean the air screen in a water soluble cleaner such as GUNK.

## CHOKE SOLENOID

The choke solenoid is a 12 volt DC operated unit that functions to close the choke plate in the carburetor when the ON switch is depressed during engine start-up.

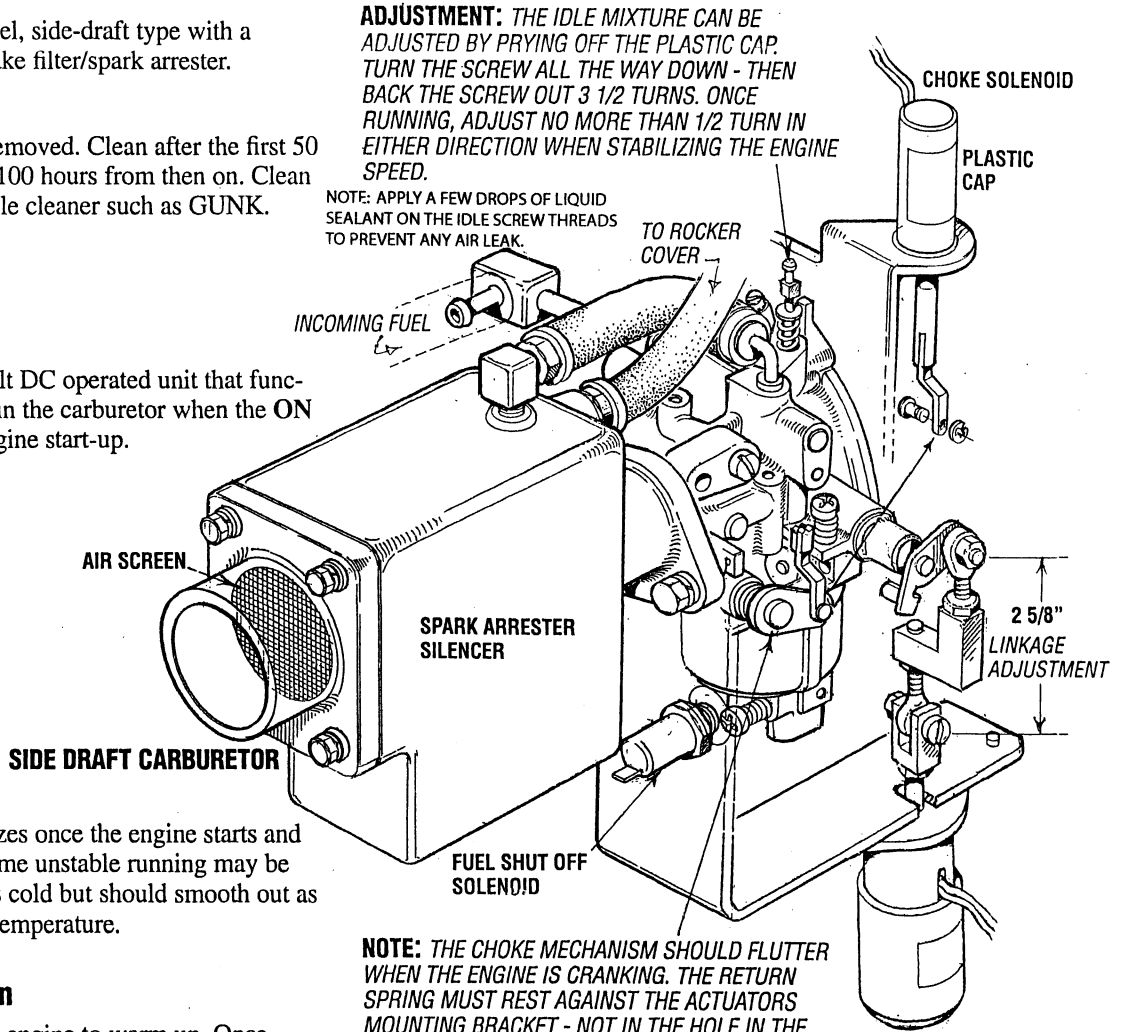
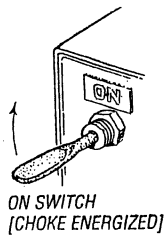

The choke solenoid de-energizes once the engine starts and the ON switch is released. Some unstable running may be present when the engine starts cold but should smooth out as the engine reaches operating temperature.

## Confirm Proper Operation

Start the engine and allow the engine to warm up. Once warm, engage the ON switch. If the engine chokes and stops, the choke linkage needs to be lengthened to hold the choke open slightly more. *If the engine slows but continues to run, the adjustment is ok.*

## Linkage Adjustment

Adjust the linkage so that when the choke solenoid is energized, the choke butterfly/lever is open approximately 1/16". Adjust the linkage so the pin hole in the linkage is approximately 1/16" beyond the fully closed choke lever.. then connect the choke lever to the linkage. Refer to the *IDLE MEASURE ADJUSTMENT* at the top of this page.

## Speed Actuator Adjustment

The speed actuator adjustment should be the only device in control of the throttle's position. The throttle linkage's eye bolts must be 2 5/8" apart (see illustration. The throttle should be in full fuel position when the unit is shutdown.

**NOTE:** THE CHOKE MECHANISM SHOULD FLUTTER WHEN THE ENGINE IS CRANKING. THE RETURN SPRING MUST REST AGAINST THE ACTUATORS MOUNTING BRACKET - NOT IN THE HOLE IN THE CASTING BOSS.

**SPEED ACTUATOR:** THE SPEED ACTUATOR SHOULD MOVE FREELY. KEEP THE SOLENOID DRY AND LUBRICATE THE LINKAGE WITH TEFLON OR GRAPHITE LUBRICANT ONLY.

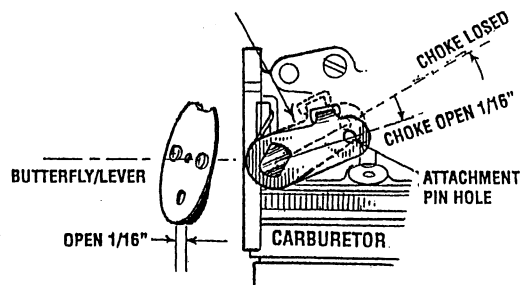

# DISTRIBUTOR

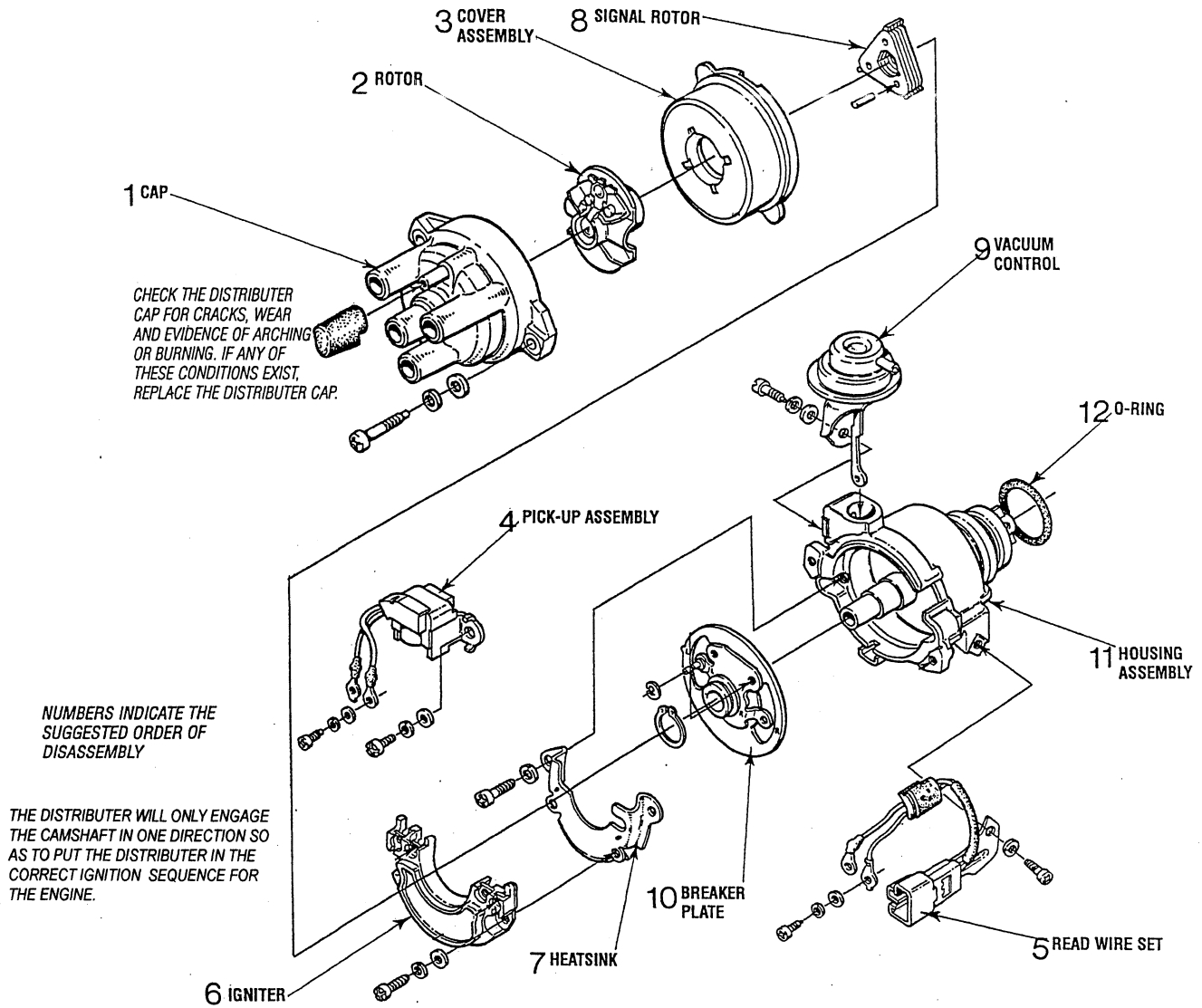

## TESTING THE PICK UP COIL

STANDARD RESISTANCE VALUE: 420 - 540 K $\Omega$

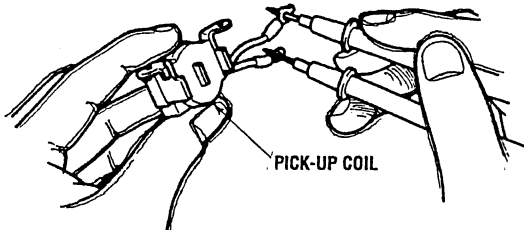

Check that when a screwdriver is passed near the iron core of the pick-up assembly the needle of the tester deflects.

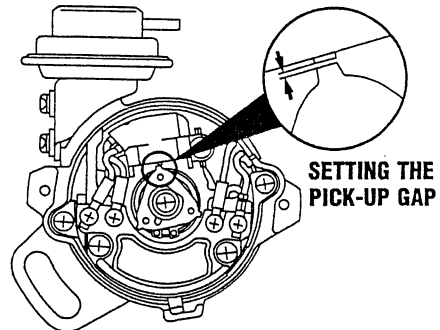
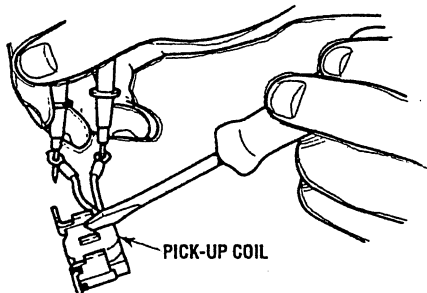

Adjust the point gap of the pick-up assembly between the rotor and the pick-up.

STANDARD GAP: 0.35mm TO 0.40mm

## INSPECTING SPARK PLUGS

Check the plugs for carbon build-up and burning. Check the plug gap.

SPARK PLUG GAP: 0.028 - 0.031 in (0.7 - 0.8 mm)

# STARTER MOTOR

## BENCH TESTING THE STARTER MOTOR

When bench testing the starter motor, make certain it is securely held in place.

### Motor Test

1. Using a fully charged battery, run a jumper from the batteries (+) post to the connecting lead that has been removed from terminal C..
2. Connect another jumper from the battery (-) post to the starter motor's housing (momentarily). If the motor fails to run, the motor is the problem.

## DISASSEMBLING THE MOTOR

**NOTE:** Closed type bearings are used on this series of generators. During the dismantling, be careful not to damage the protective cover rings.

To prevent damage to the rotor and stator windings while removing the rotor, place cardboard between the packages and remove the rotor by pulling it out gentle.

## Magnetic Switch Test

1. Connect a jumper lead from the starter's S terminal to the battery (+) post.
2. Connect a jumper from the battery (-) post to the starter motor's C terminal (momentarily).
3. If the pinion gear fails to pop out, the problem is with the magnetic switch.

## DISASSEMBLING THE MAGNETIC SWITCH

1. Remove the drive end frame mounting screws.
2. Disassemble carefully the overrunning clutch, ball, spring, gears, rollers, and retainer.
3. Remove the plunger end cover screws and take out the plunger.

**NOTE:** When reassembling, apply grease to all the gear teeth, the overrunning clutch and the ball.

**TIGHTENING TORQUE B TERMINAL NUT**  
 5.9 - 11.8 Nm  
 4.3 - 8.7 ft-lb

## STARTER MOTOR SERVICE TYPICAL STARTER

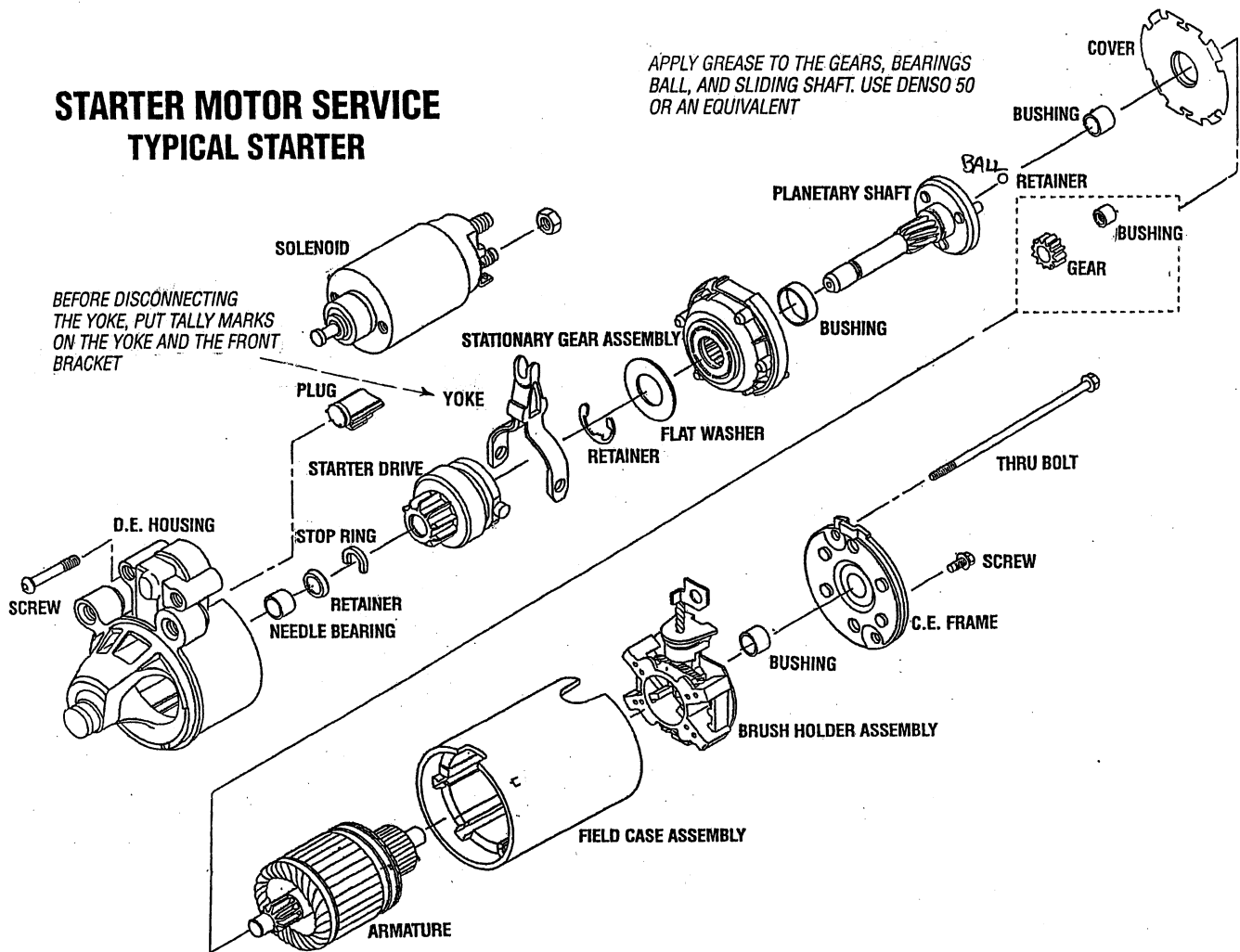

# STARTER MOTOR SERVICE

## BRUSH WEAR

1. If the contact face of the brush is dirty or dusty, clean it with emery paper.
2. Measure the brush length (A) with vernier calipers.
3. If the length is less than the allowable limit, replace the yoke assembly and brush holder.

**BRUSH LENGTH (A) 18.0MM (0.7086IN)**  
**LIMIT 11.0MM (0.4331IN)**

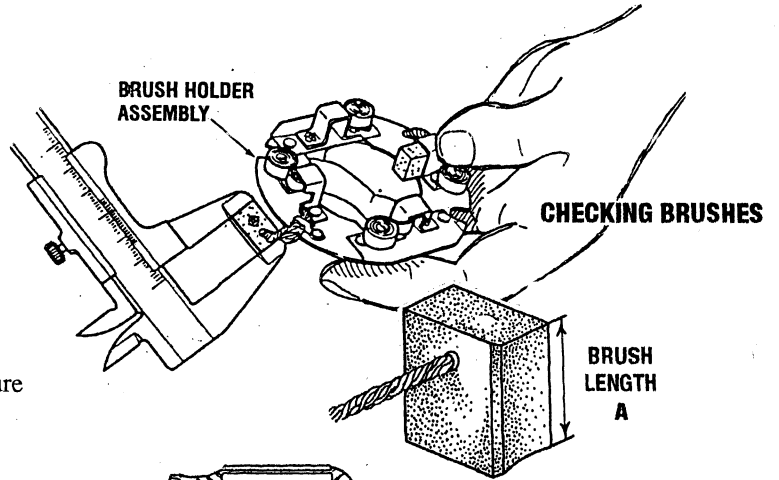

## ARMATURE COIL

1. Check the continuity across the commutator and armature coil core with an ohmmeter.
2. If it conducts, replace the armature.
3. Check the continuity across the segments of the commutator with an ohmmeter.
4. If it does not conduct, replace the armature.

**RESISTANCE: COMMUTATOR ARMATURE COIL - INFINITY**  
**COMMUTATOR SEGMENT - 0Ω**

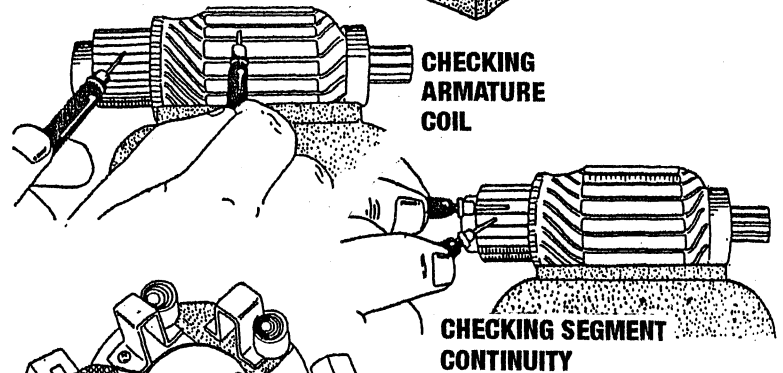

## BRUSH HOLDER

1. Check the continuity across the brush holder and the holder support with an ohmmeter.
2. If it conducts, replace the brush holder.
3. If the length is less than the allowable limit, replace the yoke assembly and brush holder.

**RESISTANCE: BRUSH HOLDER TO HOLDER SUPPORT - INFINITY**

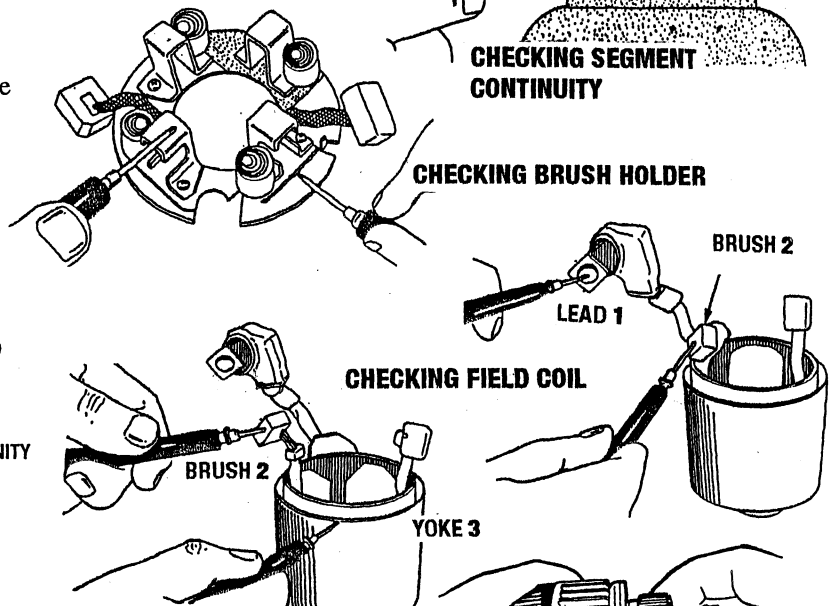

## FIELD COIL

1. Check the continuity across the lead (1) and brush (2) with an ohmmeter.
2. If it does not conduct, replace the yoke assembly.
3. Check the continuity across the brush (2) and yoke (3) with an ohmmeter.
4. If it conducts, replace the yoke assembly.

**RESISTANCE: LEAD (1) - BRUSH (2) 0Ω / BRUSH (2) - YOKE (3) - INFINITY**

## BEARING

1. Check the bearing for smooth rotation.
2. If it does not rotate smoothly, replace it.

## STATOR

1. Measure the resistance across each lead of the stator coil with an ohmmeter.
2. If the measurement is not within factory specifications, replace it.
3. Check the continuity across each stator coil lead and core with an ohmmeter.
4. If infinity is not indicated, replace it.

**RESISTANCE: LESS THAN 1.0Ω**

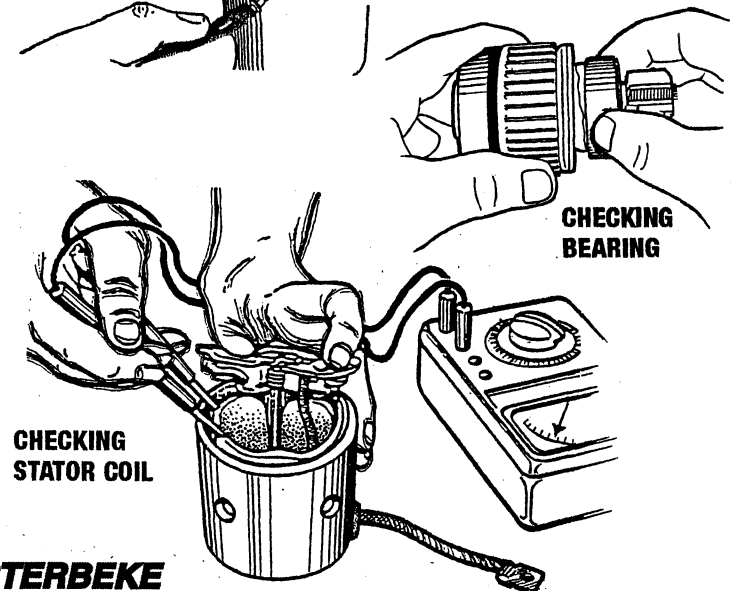



# STARTER MOTOR SERVICE

## OVER-RUNNING CLUTCH

1. Inspect the pinion gear for wear or damage. If there is any defect, replace the over-running clutch assembly.
2. Check that the pinion gear turns freely and smoothly in the over-running direction and does not slip in the cranking direction. If the pinion slips or fails to rotate in both directions, replace the over-running clutch assembly.

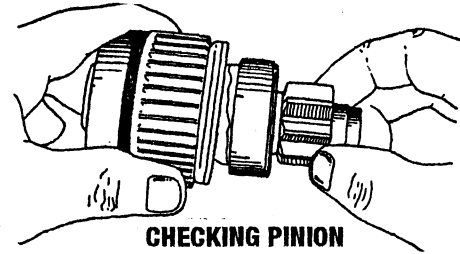

## COMMUTATOR AND MICA

1. Check the contact face of the commutator for wear, and grind the commutator with emery paper if it is slightly worn.
2. Measure the commutator O.D. with an outside micrometer at several points.
3. If the minimum O.D. is less than the allowable limit, replace the armature.
4. If the difference of the O.D. exceeds the allowable limit, correct the commutator on a lathe to the factory specifications.
5. Measure the mica undercut.
6. If the undercut is less than the allowable limit, correct it with a saw blade and chamfer the segment edges.

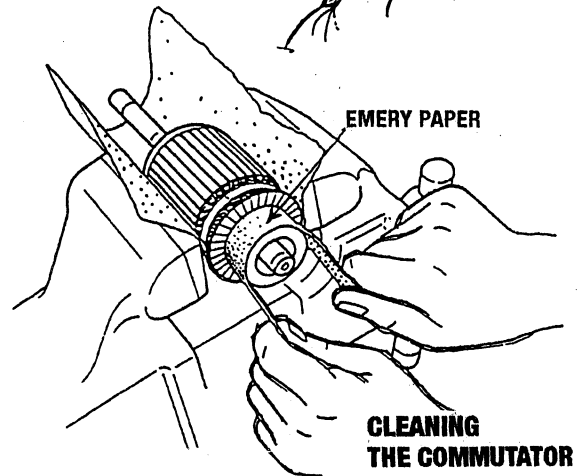
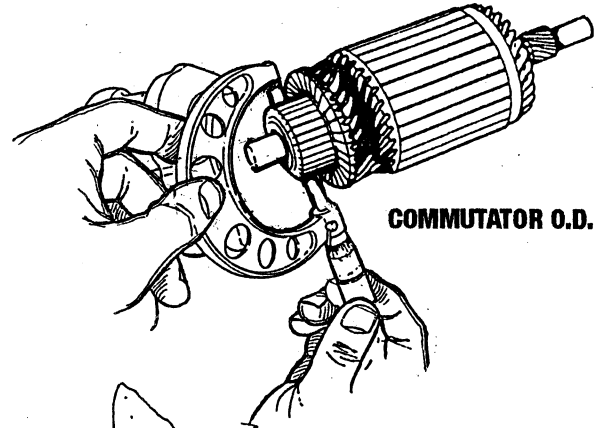

COMMUTATOR O.D. - 32MM (1.2598IN)  
LIMIT - 31.4MM (1.2362IN)  
MICA UNDERCUT - 0.50 - 0.80MM (0.0197 - 0.0315IN)  
LIMIT - 0.20MM (0.0079IN)

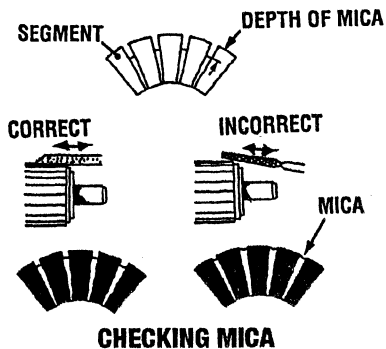

**CAUTION:** Before installing, thoroughly clean the starter flange and mounting surfaces, remove all old paint and rust. Starter performance largely depends on the quality of the wiring. Use wire of sufficient size and grade between the battery and starter and fully tighten to the terminal.

# STARTER MOTOR SERVICE

ELECTRICAL JUMPER field fabricated  
For starter motor (to by-pass the control panel start)

## TESTING WITH AN ELECTRICAL JUMPER

REFER TO THE ILLUSTRATION BELOW

Remove the **Terminal S** wire from the ignition and attach the lead from the electrical jumper. Leave the + **positive** battery attached and clip the jumper alligator fitting to that terminal. The push button should crank the starter.

If the push button fails to crank the starter and the batteries wiring and wired connections have been checked, the starter needs to be removed for service.

**NOTE:** This electrical jumper can be fabricated using a standard push button and two connecting wires.

## TO REMOVE FOR SERVICE

1. Turn off the DC battery switch.
2. If necessary, remove any components to gain full access to the starter motor.
3. Label and disconnect the wiring from the starter. (Do not allow wires to touch, tape over the terminals).
4. Remove the starter mounting bolts.
5. Remove the starter from the engine. In some cases the starter will have to be turned to a different angle to clear obstructions,

**NOTE:** WESTERBEKE uses an ignition proof starter approved by the U.S. Coast Guard. If it is necessary to replace the starter, purchase a new starter from a WESTERBEKE dealer/distributor.

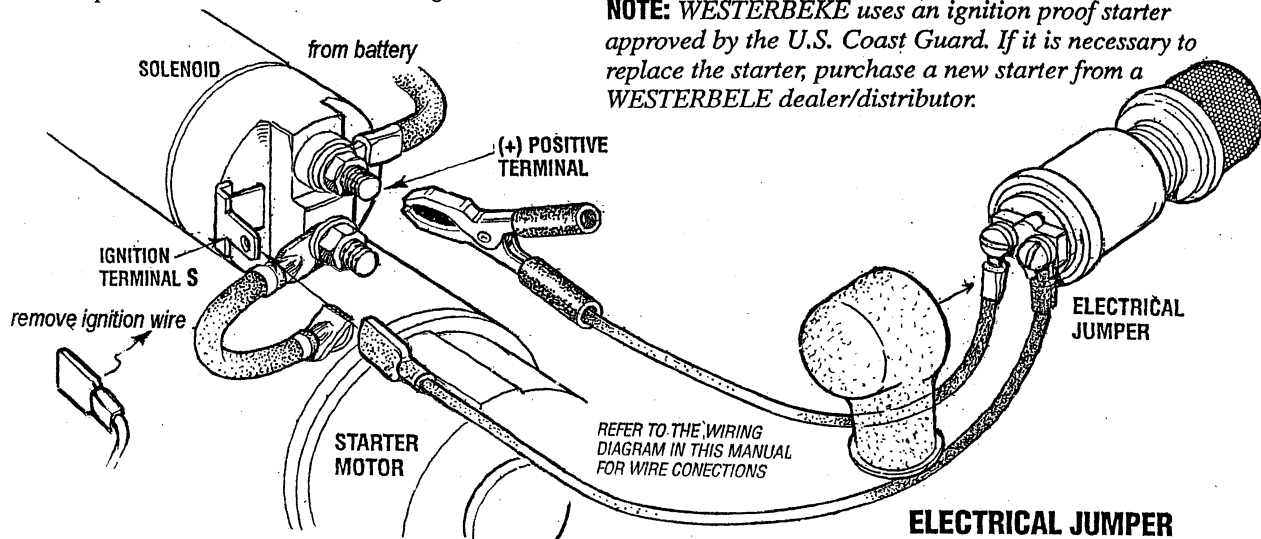

# GENERATOR WIRING DIAGRAM #46876

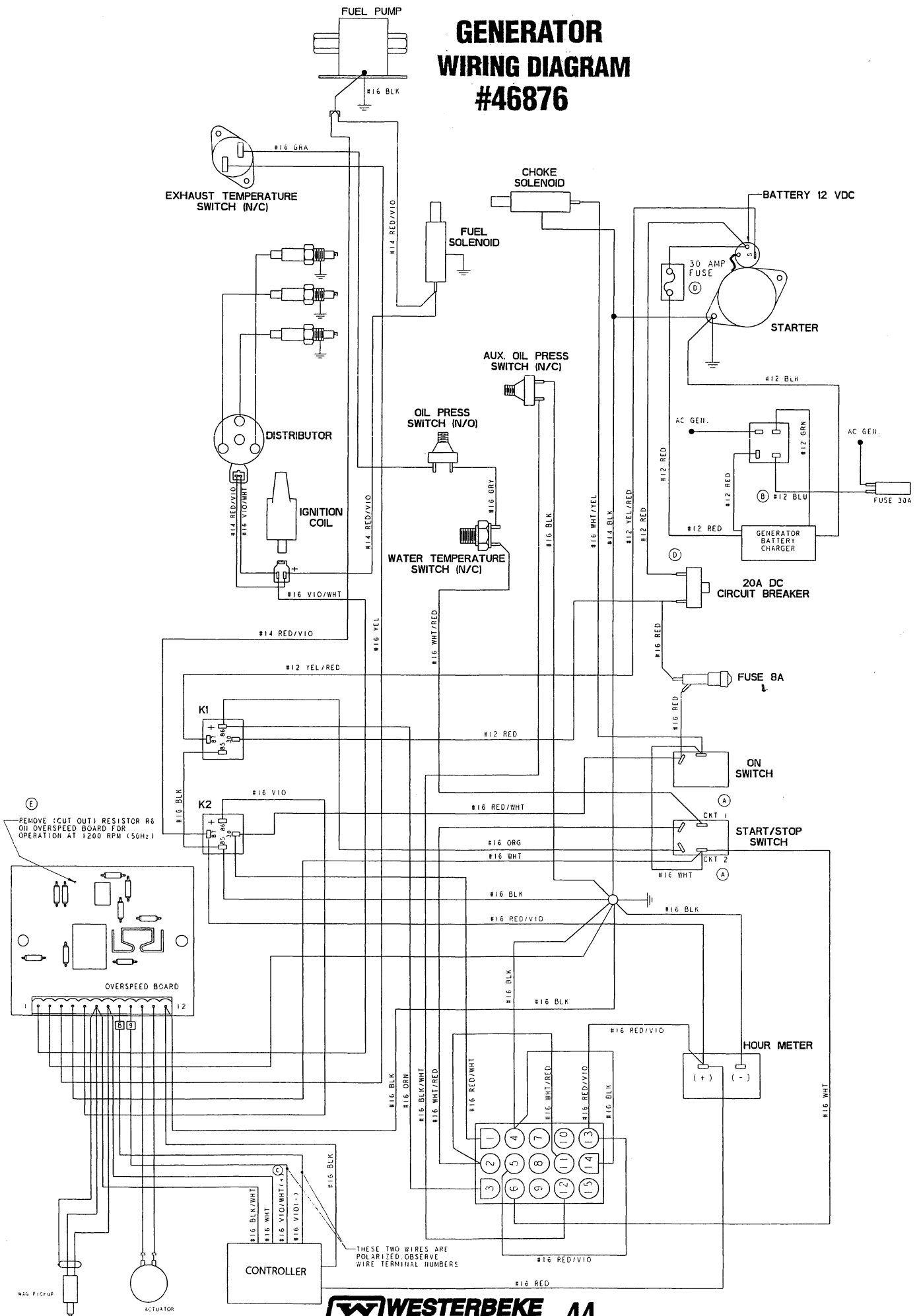

# GENERATOR WIRING SCHEMATIC #46876

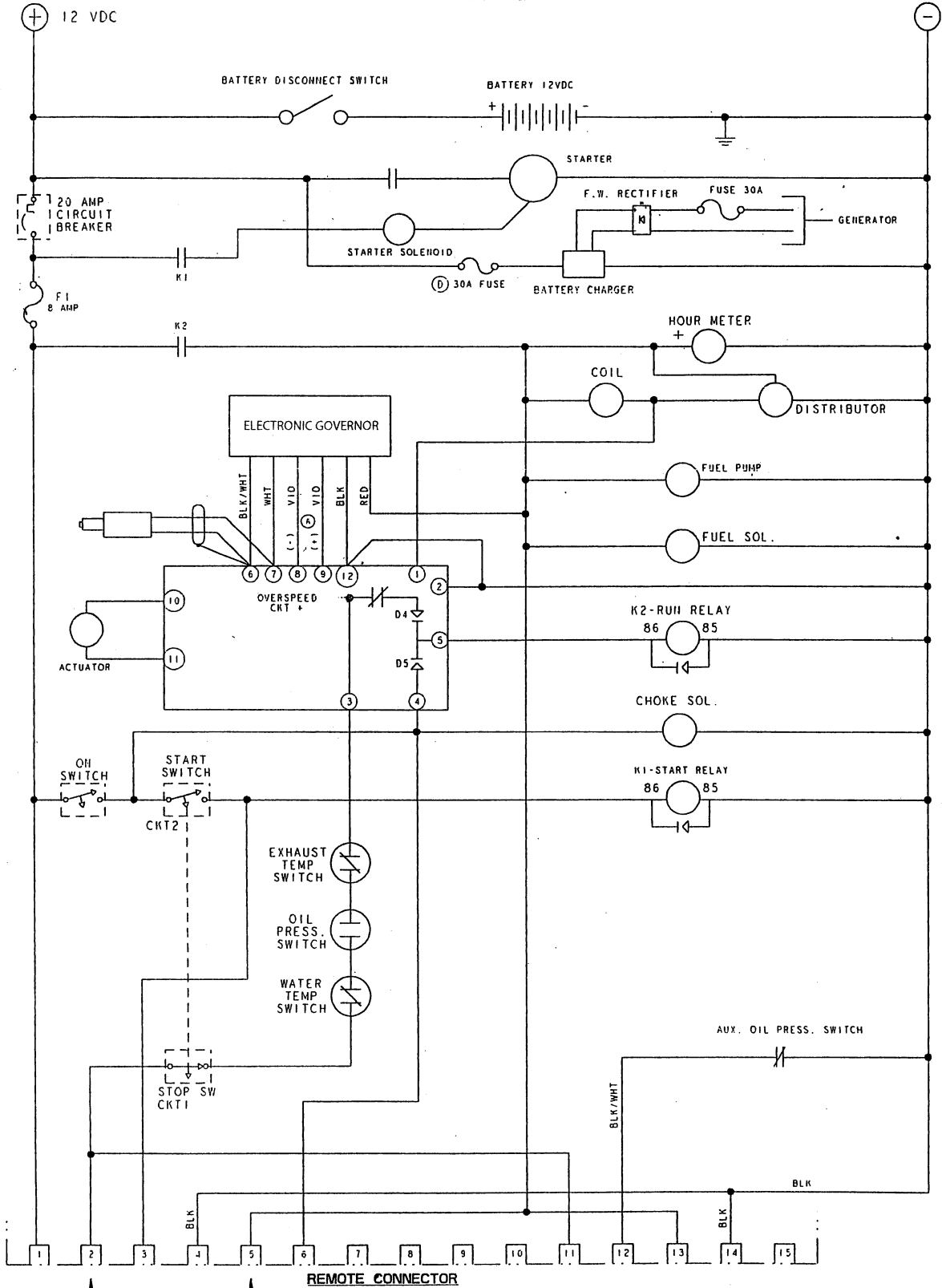

SHORTING PLUG - JUMPER PINS 2 TO 5

- NOTES:**
1. ALL WIRE #16AWG/110SDEG C 600V-ALPHA (1858/19-MIL-W-16878D TYPE B) UNLESS SPECIFIED OTHERWISE.
  2. WARNING - RELAYS K1, K2 HAVE INTERNAL DIODES ACROSS THEIR COILS. POLARITY AS INDICATED MUST BE MAINTAINED TO AVOID DAMAGE TO THE RELAYS

# REMOTE PANEL WIRING SCHEMATIC #043912

## REMOTE PANEL

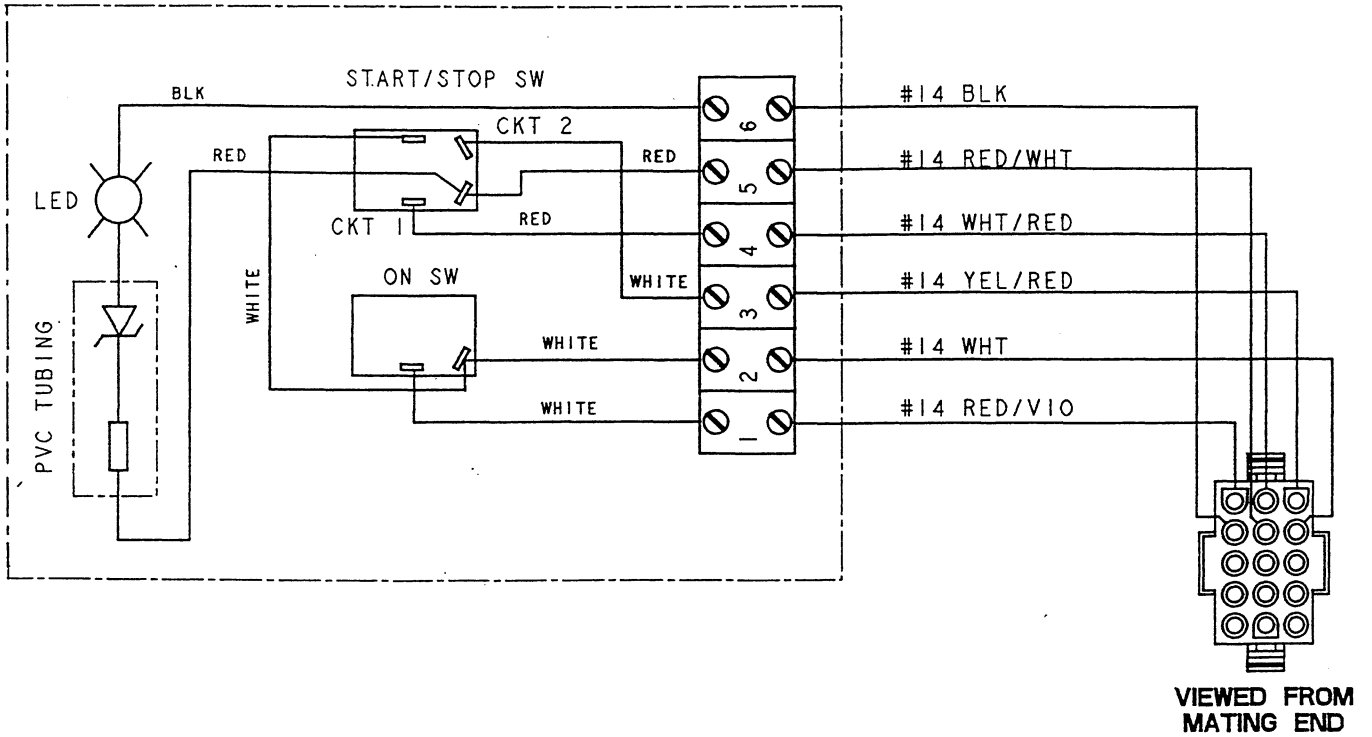

# SAFETY SHUTDOWN SWITCHES

## FUNCTION and TESTING

### OIL PRESSURE SWITCH

The Oil Pressure switch is a Normally Open contacts switch. Oil pressure closes the contacts in the switch to provide a path for DC voltage to the K2 run relay. Should the oil pressure drop below 10-5 psi, the contacts will open, interrupting the DC voltage to the K2 relay, shutting down the unit.

**TESTING:** Test the oil pressure with a mechanical gauge. By-pass the switch for test purposes by electrically tying its two electrical wire connections together. Continuity should be found across the two connections.

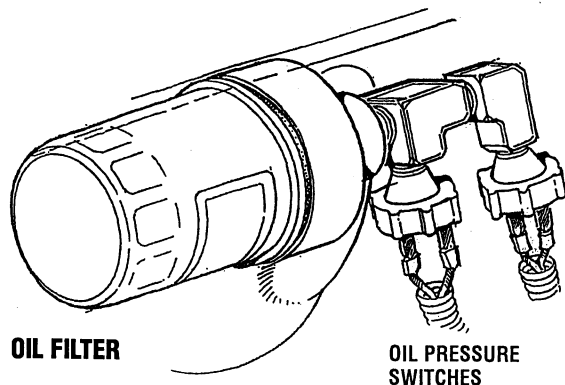

### WATER (COOLANT) TEMPERATURE SWITCH

The Water Temperature Switch is located on the lower thermostat housing. This is a Normally Closed contacts switch. High antifreeze coolant temperature will cause the contacts to open interrupting DC voltage to the K2 relay, shutting down the unit. The contacts open at 210°F (99°C). Contacts reset/close at 195°F (107°C) approximately.

**TESTING:** By-pass the switch for test purposes by tying its two electrical connections together. Testing with an ohm meter should show continuity across the two connections.

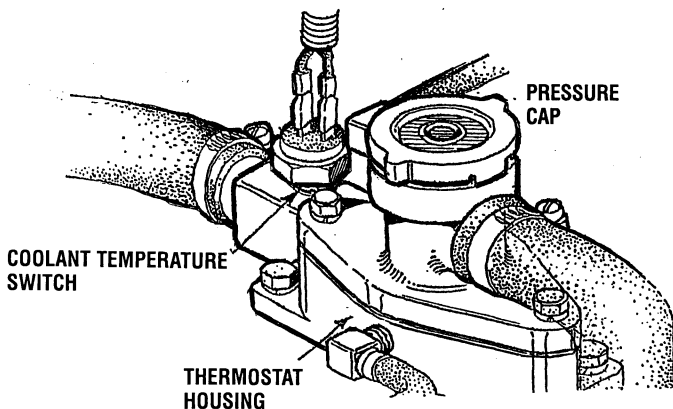

### EXHAUST TEMPERATURE SWITCH

The Exhaust Temperature Switch is located on the water injected exhaust elbow. This is a Normally Closed contacts switch. High temperature will cause the contacts to open interrupting the DC voltage to the K2 run relay, shutting down the unit. The contacts open at 260-270°F (127-132°C). Contacts reset/close at 225°F (107°C) approximately.

**TESTING:** By-pass the switch for test purposes by tying its two electrical connections together. An ohm meter should show continuity across the two connections.

**NOTE:** When replacing the switch, be sure to apply thermal paste to the surface of the switch contacting the surface of the elbow.

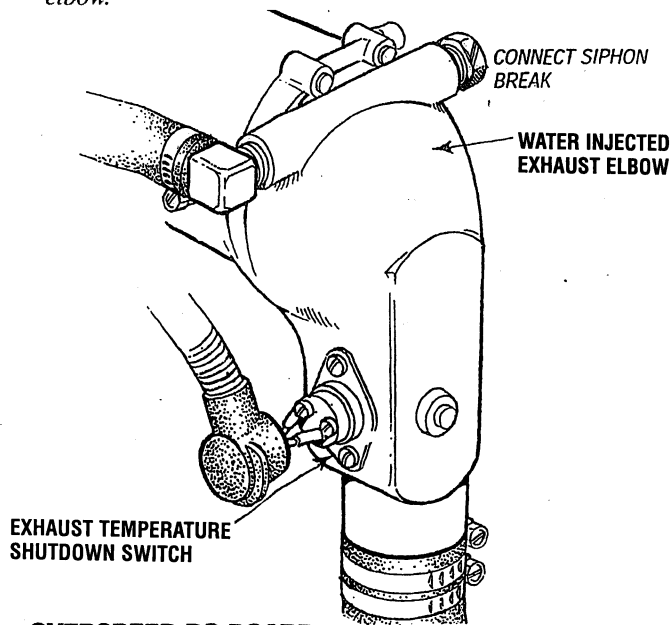

### OVERSPEED PC BOARD

An Overspeed PC Board is mounted in the units control box. It monitors the engine rpm by referencing ignition coil pulses. Should these reach a pre-set level signaling an overspeed, the contacts in a relay on the board open, interrupting the DC voltage to the K2 relay, shutting down the unit. The contacts in the relay should reset/close once the unit shuts down.

**TESTING:** By-pass the relay for test purposes by moving the terminal #3 over to the #5. Testing with an ohm meter, continuity should be found between terminal #T3 and #T5.

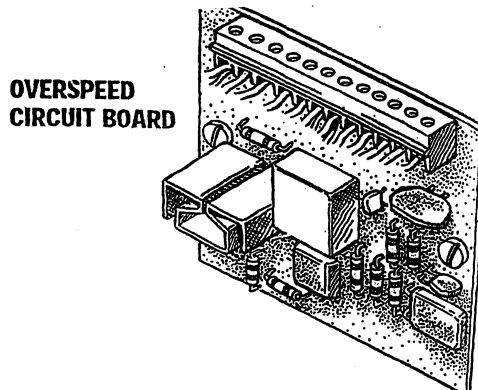

Refer to the engine/generator wiring diagrams in this manual when performing the tests above.

# CIRCUIT BREAKER / TESTING RELAYS

## ENGINE DC CIRCUIT BREAKER

The generator's DC circuit is protected by a re-settable push button DC breaker mounted on the Control box. Excess DC amperage draw through this breaker will cause the breaker to trip to the OFF position. In this event, DC power to the run circuit on the unit will be interrupted, shutting down the unit. Inspect the DC circuit for cause and repair. Reset the breaker and restart the unit.

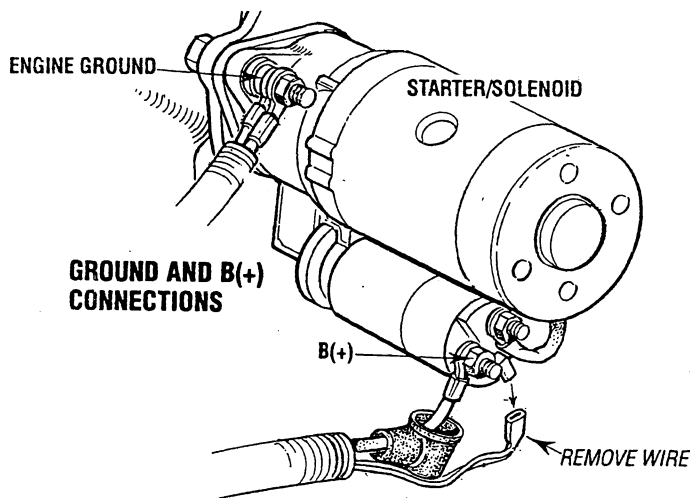
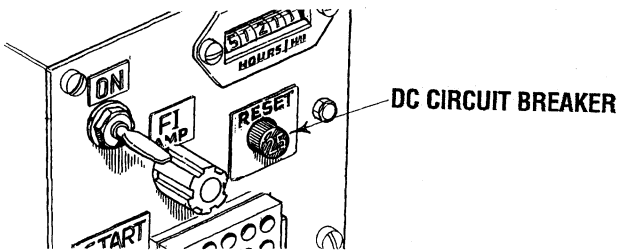

## GENERAL

All DC voltage measurements are made to the engine battery negative ground point unless specified otherwise. In making test measurements, make sure that a good ground for the meter is established, preferably the point where the negative battery is connected to the engine. Battery positive voltage is indicated as B+ and should measure no less than 11.5 volts.

AC voltage measurements should be made with a true RMS AC meter to insure accuracy.

## TESTING RELAYS

The relays used in the control system have coils which are polarized by the fact that they have internal free wheeling suppression diodes across them. Relay coil terminal 86 must be maintained (+), terminal 85(-). The relay coil is rated 12V DC, and the coil resistance is typically 85 ohms. With B+ on terminal 86, direct grounding of terminal 85 is permissible for testing purposes.

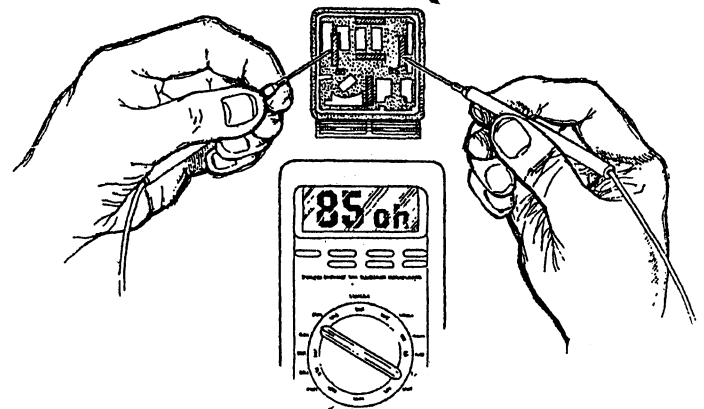
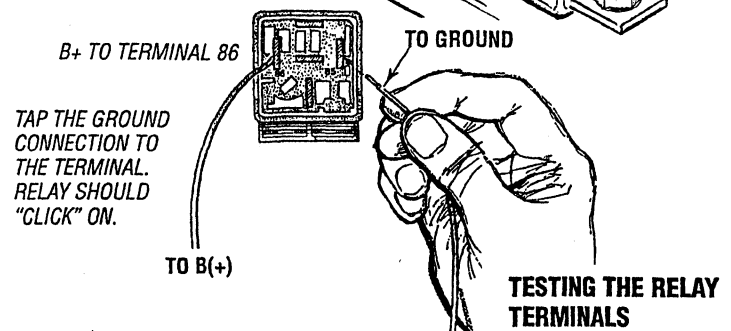
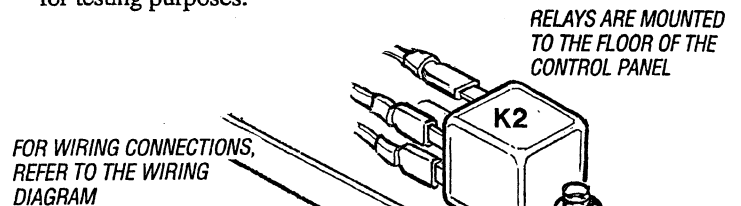

# TESTING THE IGNITION COIL

## INSTRUCTIONS

Unplug the electrical connections from the coil carefully noting the position of the two electrical connections **A** and **B** as they must be reconnected in the exact same position.

Place the ohmmeter leads on terminals **A** and **B** as shown.

**A to B - 1.5 ohm**

Place the leads between **A** and the high tension coil **HT** connection.

**A to HT - 25.0 - 27.0 kΩ**

Place the leads between **B** and the high tension coil **HT** connection.

**B to HT - 25.0 - 27.0 kΩ**

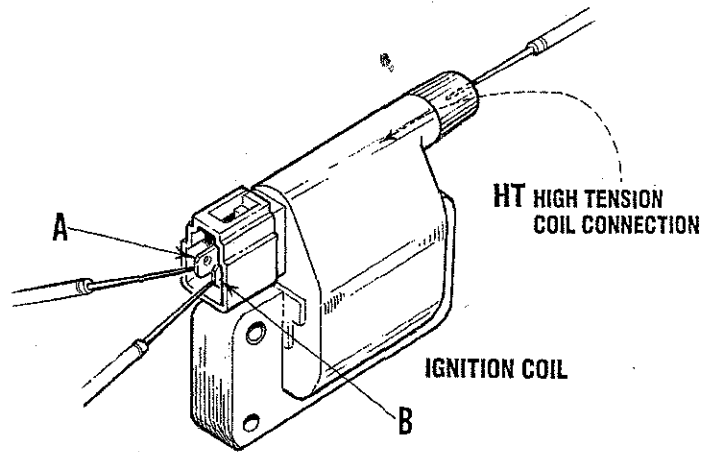

# TESTING THE IGNITER

## DESCRIPTION

To static test the igniter first unplug the two connectors at the distributor plug. Note that the connections to the distributor are two separate push on spade connections and it is important to pay attention to the location of the connection points so they can be reconnected properly after testing the igniter.

Place your Ohm meter (an analog type meter is required) on the "SG" and "C" terminals as shown. Take note of the Ohm reading then reverse the leads of the meter and note the reading in the opposite direction.

The Ohm reading should be less than 100 Ohms in one direction and there should be no resistance reading (infinite resistance) in the other direction.

The following indicates a faulty igniter:

Infinite resistance in both directions.

Infinite in one direction and above 100 in the other.

Low resistance in both directions.

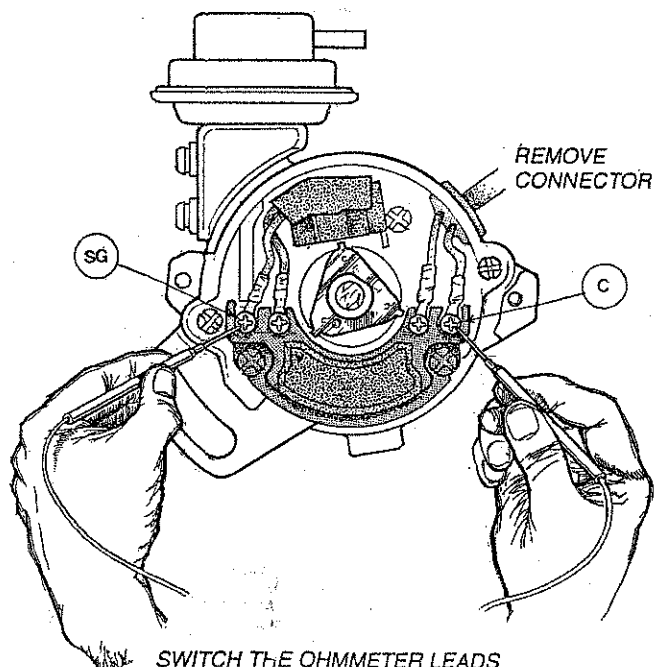

SWITCH THE OHMMETER LEADS BACK AND FORTH BETWEEN TERMINALS SG AND C AND READ THE VALUES.



# PANEL COMPONENTS/WIRING

## ELECTRONIC SPEED CONTROLLER PN. 049608

NOTE: For wiring connection refer to the diagram below:

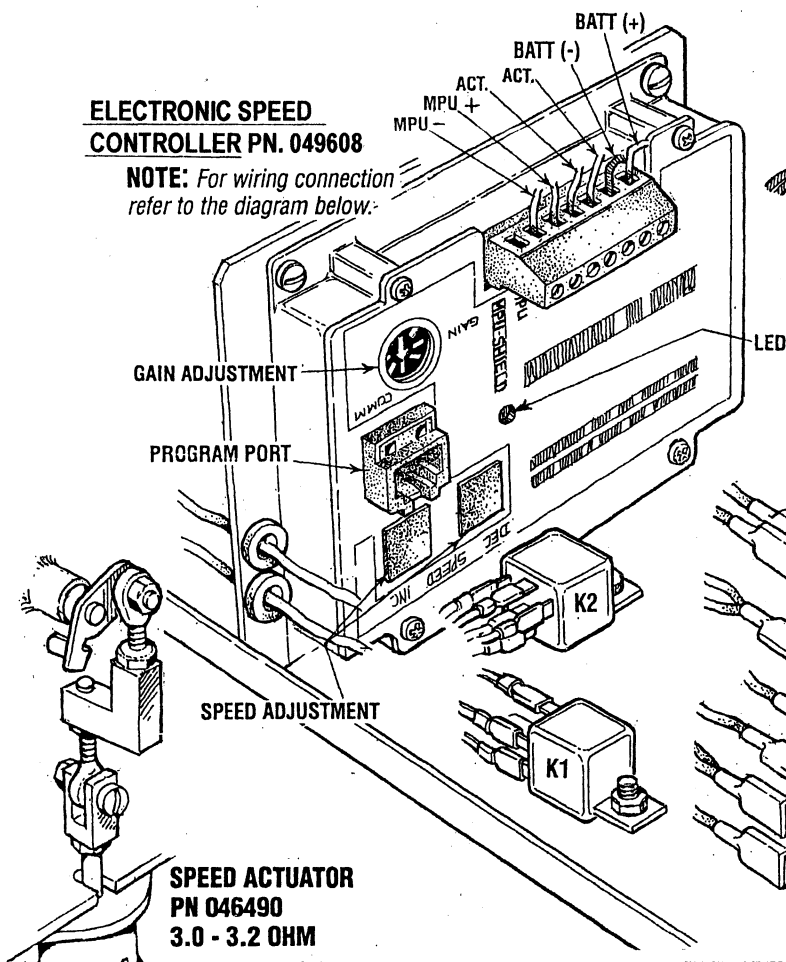

## OVERSPEED PC BOARDS

60Hz #046732

50Hz # 048801

NOTE: For wiring connection refer to the diagram below.

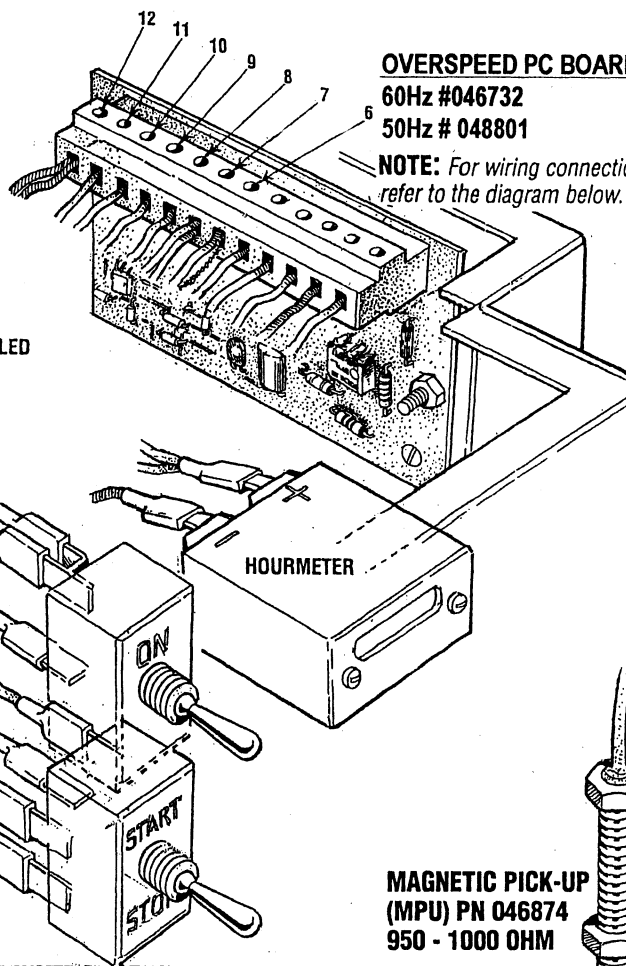

**SPEED ACTUATOR**  
PN 046490  
3.0 - 3.2 OHM

**MAGNETIC PICK-UP (MPU) PN 046874**  
950 - 1000 OHM

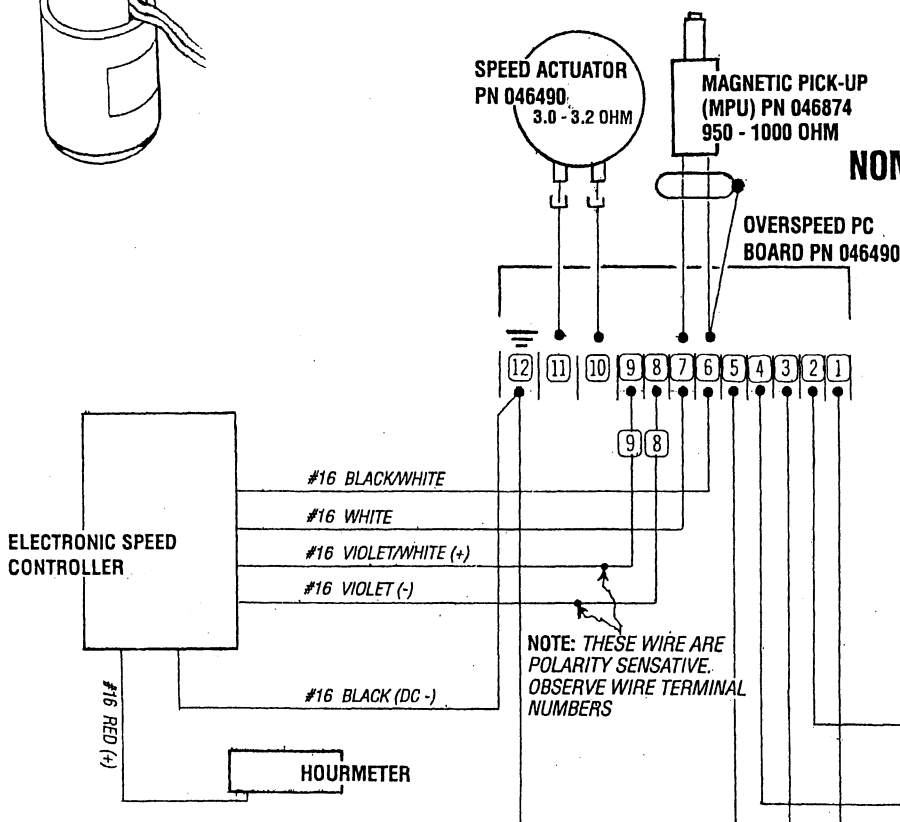

## WIRING SCHEMATIC

### NOMINAL VOLTAGES at IDLE and 1800 RPM

(Idle is obtained using the DEC button on the Controller. Reducing engine rpm to a smooth low idle rpm.)

#### TERMINALS

TERMINALS	VOLTAGE
#7 → #6	1.5 - 2.5 VAC
#9 → #8	5.5 - 5.5 DC
#10 → #11	6.5 - 7.0 DC
#16 → #16 RED BLACK	12.2 DC

#### 1800 RPM

#### TERMINALS

#7 → #6	4 - 7 AC
#9 → #8	5.5 - 6.5 DC
#10 → #11	6.0 - 6.5 DC
#16 → #16 RED BLACK	13.2 DC

# THE ELECTRONIC GOVERNOR

## DESCRIPTION

A generator's engine must run at a constant speed to enable the generator to produce the stable AC power (hertz) required.

The Electronic Governor consists of three components, the **CONTROLLER**, a pc board installed in the control panel. A **MAGNETIC PICK-UP (MPU)** installed in the bellhousing over the engine flywheel and the linear **ACTUATOR** mounted on the engine and attached by linkage to the injection pump throttle control.

The Electronic Governor regulates the engine speed by sensing the engine's RPM with the magnetic pick-up at the flywheel. The governor's controller continuously monitors the engine's speed and if there is any discrepancy, the controller signals the actuator and the actuator adjusts the engine to the desired speed electronically.

## CONTROLLER ADJUSTMENT

The controller has two adjustments: the **SPEED** adjustment is used to increase or decrease the engine's speed to the desired hertz. The **GAIN** adjustment affects the reaction time of the actuator to the generator load changes.

**NOTE:** A high gain adjustment can induce an oscillating of the actuator producing a hunting mode. In such cases, lessen the gain adjustment.

## CALIBRATION

1. With no power to the governor (engine not running), adjust the **GAIN** potentiometer to 9:00 o'clock.
2. Start the engine. The green LED will indicate the governor is energized. Adjust the controller for the desired speed by pressing the decrease or increase buttons.

**NOTE:** Controllers are factory adjusted to minimum RPM. However, for safety, one should be capable of disabling the engine if an overspeed should exist.

3. At no load, turn the **GAIN** potentiometer clockwise until the engine begins to hunt. If the engine does not hunt, physically upset the actuator linkage.
4. Turn the **GAIN** potentiometer counterclockwise until engine runs stable.

**NOTE:** The controller operates with either 12 or 24VDC. The minimum voltage the controller must have to operate is 9.0VDC. The maximum voltage the controller will operate with is 30VDC. If the DC voltage falls below the minimum or above the maximum, the controller will not operate until the voltage problem is corrected.

**NOTE:** High DC voltage will damage the controller.

## ELECTRONIC GOVERNOR ADJUSTMENTS

When the ON switch is depressed, the green LED light on the Controller will start to blink indicating the controller is receiving proper DC voltage. When the unit starts, the actuator will draw the throttle to a pre-set position and the LED will blink faster.

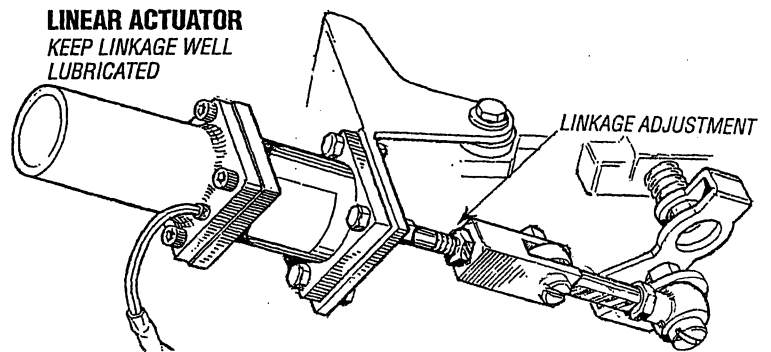
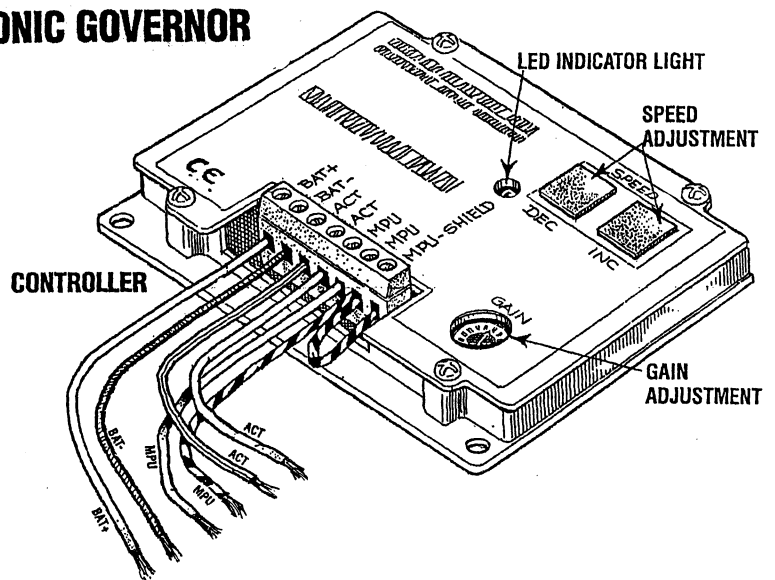

Start the engine. The speed should be in the low idle range 600-700 rpm. If the engine speed is higher than this idle range, shut the engine down. Check the linkage between the actuator and throttle arm. The throttle arm stop should be about touching the open idle stop screw boss. Adjust the linkage to position the throttle lever. Restart the engine and using the speed adjustment buttons bring the engine speed to 1800 rpm (60Hz), 1500 rpm (50Hz). Momentarily push the actuator linkage towards the actuator and release. The actuator should quickly regain proper speed. If there is any hunting, adjust the gain towards zero (0) until this hunting is removed.

When the gain is adjusted, you may need to re-adjust the speed at no load, shut the generator down.

Start the generator.

Check speed (hertz) set at 50Hz/60Hz.

Load the generator.

If the governor is slow to react and maintain 50Hz/60Hz, adjust the gain clockwise. Again you may need to adjust the speed at no load.

You will find the governor will maintain set engine RPM  $\pm 0.5$  Hz right up to the full rated amperage output for the generator.

# THE ELECTRONIC GOVERNOR

## MAGNETIC PICK-UP [MPU] INSTALLATION

The MPU is installed in the threaded opening on the side of the flywheel bellhousing. This positions the MPU over the teeth of the flywheel ring gear.

Viewing through this opening, manually rotate the engine crankshaft so as to position the flat of one of the ring gear's teeth directly under the opening. Thread the MPU into the opening until it gently contacts the flat of this tooth (Thread is 3/8" x 24). Back the MPU out of the opening one turn and then lock it in this position with the jam nut. This will position the end of the MPU approximately 0.030 inches away from the flats of the ring gear teeth.

To ensure the MPU is positioned correctly, slowly rotate the crankshaft by 360° by hand to assure there is no physical contact between the MPU and the ring gear teeth.

If contact is felt between the MPU and the flywheel teeth, the MPU may be damaged. Remove the MPU and inspect it. Replace if necessary and repeat the above installation procedure.

**NOTE:** When replacing the Magnetic Pick-Up (MPU) it **MUST** be replaced without cutting and splicing into the existing wiring cable. Doing so will cause a erratic AC signal to the controller.

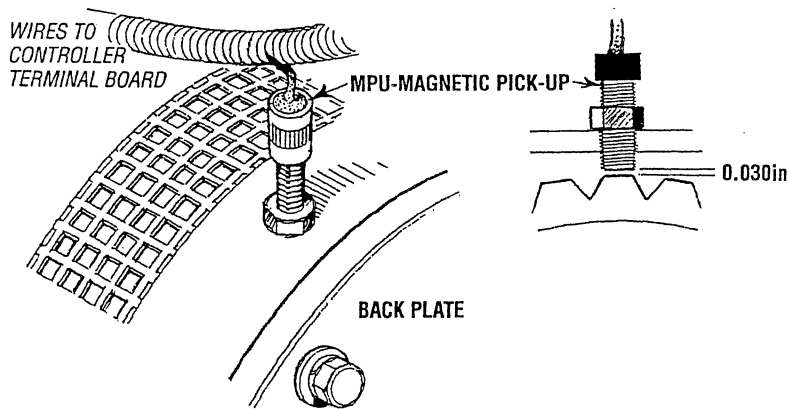

## GOVERNOR CIRCUIT VOLTAGES

Below are the voltages normally found in the governor circuit when the system is functioning normally. These voltages are an approximate and should be help in troubleshooting a system that is not functioning correctly.

### DC Voltage into Controller

Bat + to Bat - (battery charging voltage 13.5 - 14.5 VDC)

### DC Voltage to Actuator

ACT to ACT (5.5 - 6.5 VDC)

### AC Voltage from MPU into Controller

MPU to MPU (2.5 - 7.0 VAC)

This voltage spread is the result of the distance the MPU is positioned from the flat of the flywheel ring gear tooth.

The closer to the tooth, the higher the AC signal. The further away, the lower the AC signal.

# ELECTRONIC GOVERNOR TROUBLESHOOTING

PROBLEM	TEST/CHECK	CORRECTION
<p>Unit starts, then overspeeds and shuts down.</p> <p><b>NOTE:</b> <i>When troubleshooting, manually operate the throttle to prevent an overspeed or disconnect the throttle from the actuator and operate manually.</i></p>	<ol style="list-style-type: none"> <li>1. Check DC voltage between terminal #12 and + connection on hourmeter when ON switch is depressed.</li> <li>2. Check the AC signal from the MPU while cranking, voltage should be 1.5 - 2.5 VAC.</li> <li>3. Check the actuator.</li> <li>4. Check the controller.</li> </ol>	<ol style="list-style-type: none"> <li>1. Charge starting battery. Start unit, troubleshoot battery, charge circuit.</li> <li>2. Check the MPU resistance value and positioning. Adjust and replace as needed.</li> <li>3. Check the resistance value. Apply 12VDC across leds. Should fully retract. Replace as needed.</li> <li>4. Manually control unit. Start and check DC voltage between #9 and #8, between #11 and #10. Replace controller or OS board as needed.</li> </ol>
<p>Unit starts, runs at idle.</p> <p><b>NOTE:</b> <i>Less than one volt DC found between terminals #9 and #8 and high DC voltage-10 volts or higher between terminals #11 and #10 indicated a faulty controller.</i></p>	<ol style="list-style-type: none"> <li>1. Incorrect speed adjustments..</li> <li>2. Faulty governor controller..</li> </ol>	<ol style="list-style-type: none"> <li>1. Check and adjust speed adjustment.</li> <li>2. Check DC voltages from controller to O/S board and O/S board to actuator.</li> </ol>
<p>Actuator hunts during operation.</p> <p><b>NOTE:</b> <i>Check carburetor adjustments before proceeding.</i></p>	<ol style="list-style-type: none"> <li>1. Improper controller adjustment.</li> <li>2. Linkage or rod end bearings are sticking or binding.</li> <li>3. Inadequate DC supply voltage.</li> <li>4. MPU positioned marginally too far away from the flywheel teeth, giving an erratic AC input signal to the controller.</li> </ol>	<ol style="list-style-type: none"> <li>1. Lessen GAIN adjustment.</li> <li>2. Lubricate and replace as needed.</li> <li>3. Manually stabilize the unit. Check the DC voltage to the controller. Correct as needed.</li> <li>4. Check the MPU signal. Adjust positioning as needed.</li> </ol>

# ENGINE ADJUSTMENTS

## ENGINE COMPRESSION TEST

1. To check the engine's compression pressure, warm up the engine then shut it down.
2. Remove the three spark plug caps and remove the three spark plugs.
3. Install a compression adapter and gauge in the spark plug hole.
4. Close the raw water seacock.
5. Crank the engine with the start motor and unplug the ignition coil and allow the compression gauge to reach a maximum reading and record.
6. Measure the compression pressure for all the cylinders. Ensure that compression pressure differential for each cylinder is within the specified unit.

**COMPRESSION PRESSURE** 189PSI (1260 Kpa) at 250 RPM  
Compression Pressure should not differ by more than 14, psi (100Kpa)

7. If a cylinder's compression or pressure differential is below the limit, add a small amount of engine oil through the spark plug hole and repeat steps 4 and 5.
  - a) If additional oil causes an increase of pressure, the piston ring and/or cylinder wall may be worn or damaged.
  - b) If additional oil does not increase compression pressure, suspect poor valve contact, valve seizure, or valve wear.
8. Reinstall three plugs and ignition wires.
9. Open the raw water seacock.

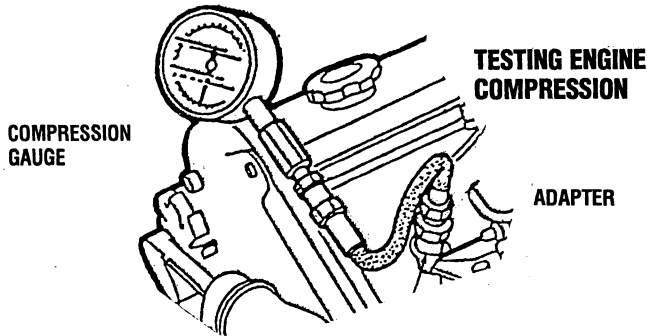

**NOTE:** Do not guess the conditions of other cylinders from a result of testing one cylinder. Be sure to measure the compression pressure for each cylinder. Look for cylinders with dramatically (at least 20%) lower compression than the average of the other cylinders. If the weak cylinder is flanked by healthy cylinders, the problem is either valve or head-gasket related. Very low compression in an adjacent cylinder indicates gasket failure. Abnormally high readings on all cylinders indicate heavy carbon accumulations, a condition that might be accompanied by high pressure and noise.

## TESTING OIL PRESSURE

To test oil pressure, remove the hex head plug from the oil gallery and install a mechanical oil pressure gauge in its place. After warming up the engine, set the engine speed at 1800 rpm and read the oil pressure gauge.

**OIL PRESSURE** BETWEEN 30 AND 40 PSI AT 1800/1500 RPM

**NOTE:** A newly started, cold engine may have an oil pressure reading up to 70 or 80 psi. A warmed engine can have an oil pressure reading as low as 30 psi. Oil pressure will vary depending upon the load placed on the generator.

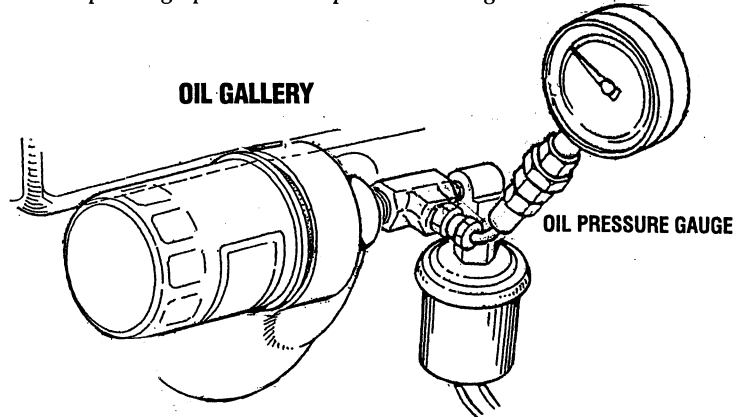

## HIGH TENSION CORDS (IGNITION WIRES)

Check the ignition wires every 500 operating hours as engine compartment heat can deteriorate the wires.

Check the resistance of each wire. Do not pull on the wire because the wire connection inside the cap may become separated or the insulator may be damaged. When removing the wires from the spark plug, grasp and twist the moulded cap, then pull the cap off the spark plug.

THE RESISTANCE VALUE IS 410 OHM PER INCH OF WIRE.

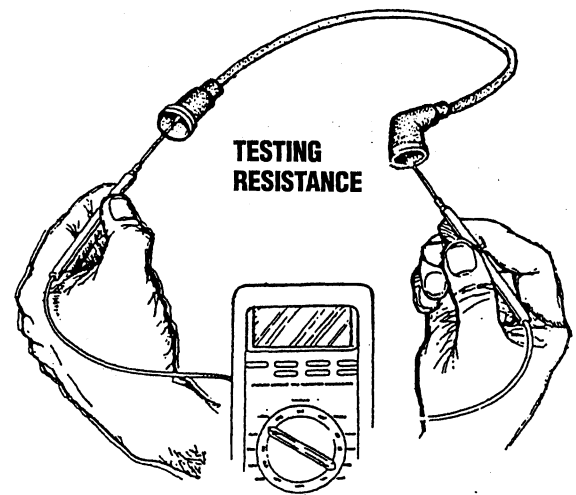

# ENGINE ADJUSTMENTS

## TORQUING THE CYLINDER HEAD BOLTS

After the initial break-in period (approximately 50 hours), the cylinder head bolts should be re-torqued.

Tighten the cylinder head bolts according to the sequence shown. Make sure the engine is cold when this is done, and loosen one head bolt one-half turn and then tighten it between 43 - 51 lb-ft (60 - 70 Nm). Then proceed to the next head bolt in the sequence. Tighten the RS (rocker cover stud) securely.

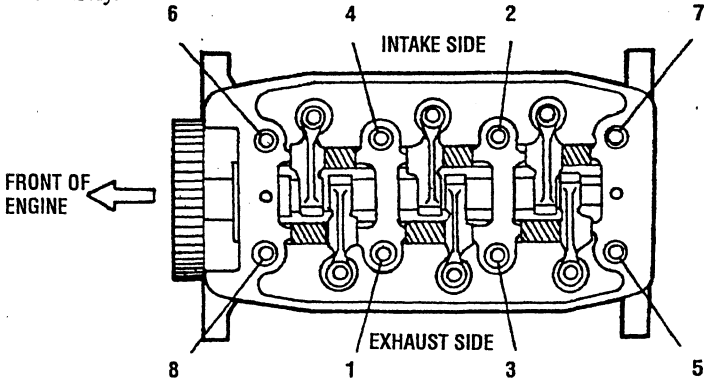

## IGNITION TIMING

1. Attach a timing light to the #1 spark plug and mark the front timing pointer to indicate 15°. Locate the timing mark on the crankshaft pulley and mark it with white chalk or a crayon.
2. Start the engine and warm it up to its normal operating temperature. Make sure the generator is operating *without a load on it*.
3. Using the timing light, align the timing mark in the front crankshaft pulley so it is just slightly before the first timing pointer. Do this by loosening and slowly rotating the distributor body. Use the following timing specifications:

Timing Specifications: 15° ± .5° BTDC at 1800 rpm  
(no load on generator)

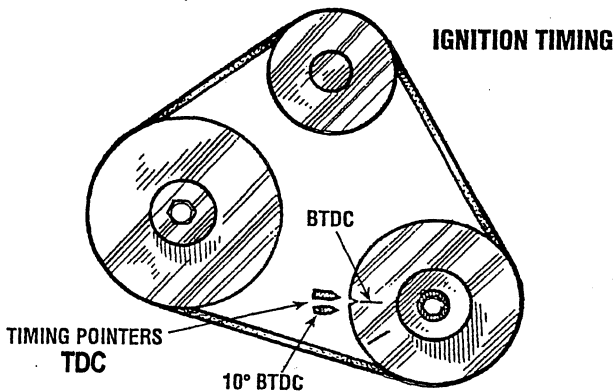

## VALVE CLEARANCE ADJUSTMENT

**NOTE:** Retorque the cylinder head bolts before adjusting the engine's valves (see **TORQUING THE CYLINDER HEAD BOLTS**).

1. Remove the rocker cover and gasket.
2. Rotate the crankshaft in the normal direction of rotation, placing the No. 1 piston at the top of its compression stroke with the exhaust and intake valves completely closed. Adjust the intake and exhaust valves for No. 1 cylinder, the exhaust valve for No. 2 cylinder, and the intake valve for No. 3 cylinder (see chart).
3. Rotate the crankshaft 180° in its normal direction of rotation. Locate the piston in No. 1 cylinder at the top of its exhaust stroke. Adjust the intake valve for No. 2 cylinder and the exhaust valve for No. 3 cylinder (see chart).

FIRING ORDER 1-3-2

CRANK ANGLE		CYLINDER #		
		1	2	3
When No. 1 piston is set at top of compression stroke	IN	●		●
	EX	●	●	
When No. 1 piston is positioned at top of exhaust stroke	IN		●	
	EX			●

4. Replace the rocker cover along with a new rocker cover gasket.

Rocker cover torque: 2.9-5.1 lb-ft (4 - 7 Nm)

VALVE CLEARANCE  
INTAKE VALVES 0.20mm (.008in)  
EXHAUST VALVES 0.30mm (.012in)

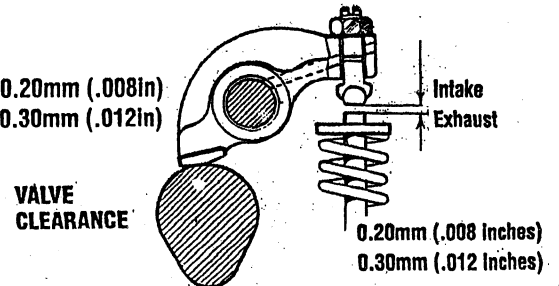

# ENGINE ADJUSTMENTS

## SPARK PLUGS

The spark plugs should be cleaned and regapped after the first 50 hour break-in period, then inspected every 250 hours thereafter and replaced as needed.

**WARNING:** Do not remove the spark plugs while the engine is hot. Allow the engine to cool before removing them.

Spark plug gap: 0.031 +/- 0.0002 in. (0.8 - 0.05 mm).

Spark plug torque: 10 - 15 lb-ft (1.5 - 2.31 kg-m).

**NOTE:** Loctite Anti-Seize applied to the threaded portion of the spark plugs will retard corrosion, making future removal of the spark plugs easier.

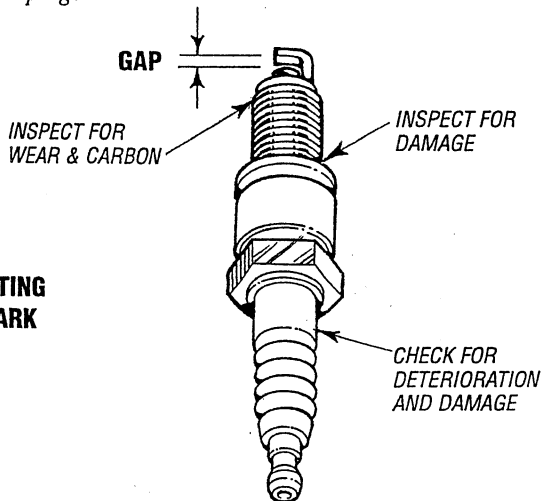

**INSPECTING THE SPARK PLUGS**

## CHOKE SOLENOID

The choke solenoid is a 12 volt DC operated unit that functions to close the choke plate in the carburetor when the ON switch is depressed during engine start-up.

The choke solenoid de-energises once the engine starts and the ON switch is released. Some unstable running may be present when the engine starts cold but should smooth out as the engine reaches operating temperature.

Keep this solenoid dry and periodically lubricate the linkage between the solenoid and the choke lever.

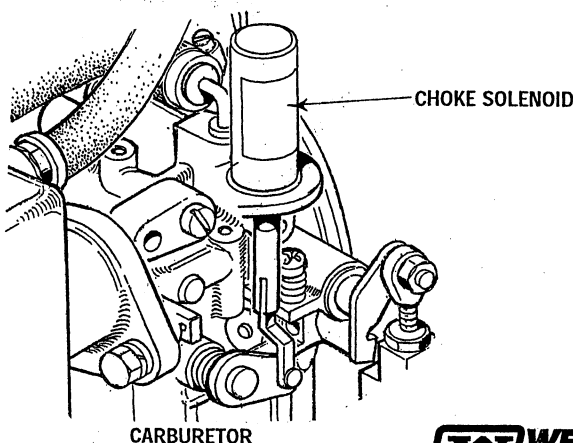

## DRIVE BELT ADJUSTMENT

The drive belt must be properly tensioned. Excessive drive belt tension can cause rapid wear of the belt and reduce the service life of the fresh water pumps bearing. A slack belt or the presence of oil on the belt can cause belt slipping.

1. Remove the belt guard.
2. To release the belt, back off the pivot bolt and loosen the bracket bolt.
3. Swing the bracket to loosen for removal.
4. Inspect the belt for frayed edges and excessive wear.
5. Re-install or replace the belt and re-tighten the bolts.

The drive belts are properly adjusted if it can be deflected no less than 3/8 inch (10mm) and no more than 1/2 inch (12mm) as the belt is depressed with the thumb at the midpoint between the two pulleys on the longest span of the belt.

**NOTE:** Maintain a 22 lb pressure to the belts outer face for proper belt operation. Spare belts should always be carried on board.

**WARNING:** Never attempt to check or adjust a drive belt's tension while the engine is in operation.

6. Operate the generator for about 5 minutes, then shut down the generator and recheck the belt(s) tension.
7. Replace the belt guard.

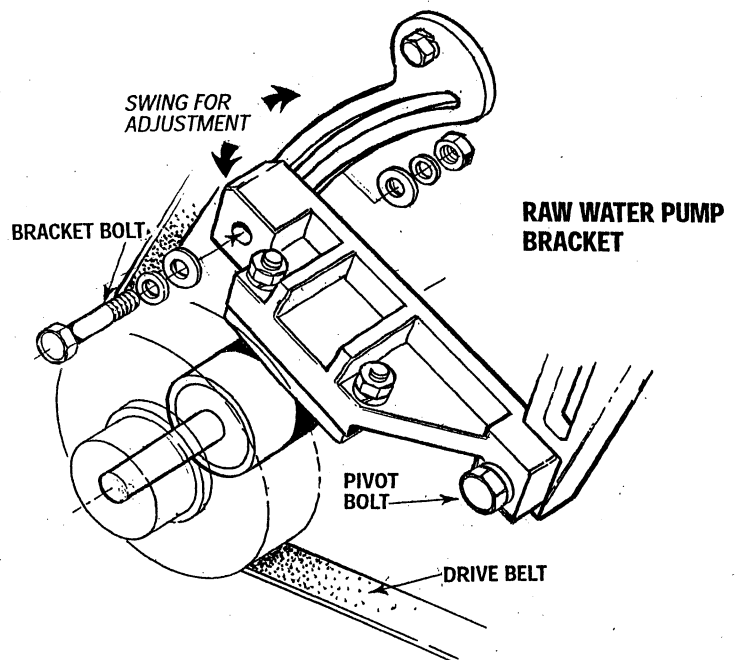

# BATTERY CHARGE CONTROLLER

## THE CHARGING SYSTEM

Westerbeke's low profile generators are equipped with a battery charge controller that is powered from a separate winding in the generator. The battery charger controller is an encapsulated, solid-state unit that supplies a DC charging voltage to the generator's starting battery while the generator is operating.

**Charging Voltage: 13.1 - 13.4 volts DC**  
**Charging Amperage: 0 - 12 amps DC**

**NOTE:** The battery charging circuit is totally separate from the AC output of the generator. The generator output affects the circuits output, but not the reverse.

A separate group of stator windings supplies AC voltage to a bridge rectifier which converts the AC current to supply the charging unit. The unit senses the needs of the starting battery and supplies a DC charge when one is needed. If you suspect that the unit is faulty (if the battery's charge is low), check the charging circuit and its components (see *TESTING THE BATTERY CHARGER*). Check all connections for cleanliness and tightness including the ground before replacing the I.C. charger.

**NOTE:** When the generator is first started, the charger will produce a low charging rate. This charging rate will rise as the generator is operated.

## Fuse Protection

A 30 amp fuse protects the windings from a failure of the bridge rectifier or the battery charger caused by a high amperage or a short circuit.

## TESTING THE BATTERY CHARGER

SOME BATTERY CHARGERS HAVE JUST THREE TERMINAL CONNECTIONS WITH THE TWO POSITIVE LEADS "PIGGY BACKED" TOGETHER TO A SINGLE TERMINAL.

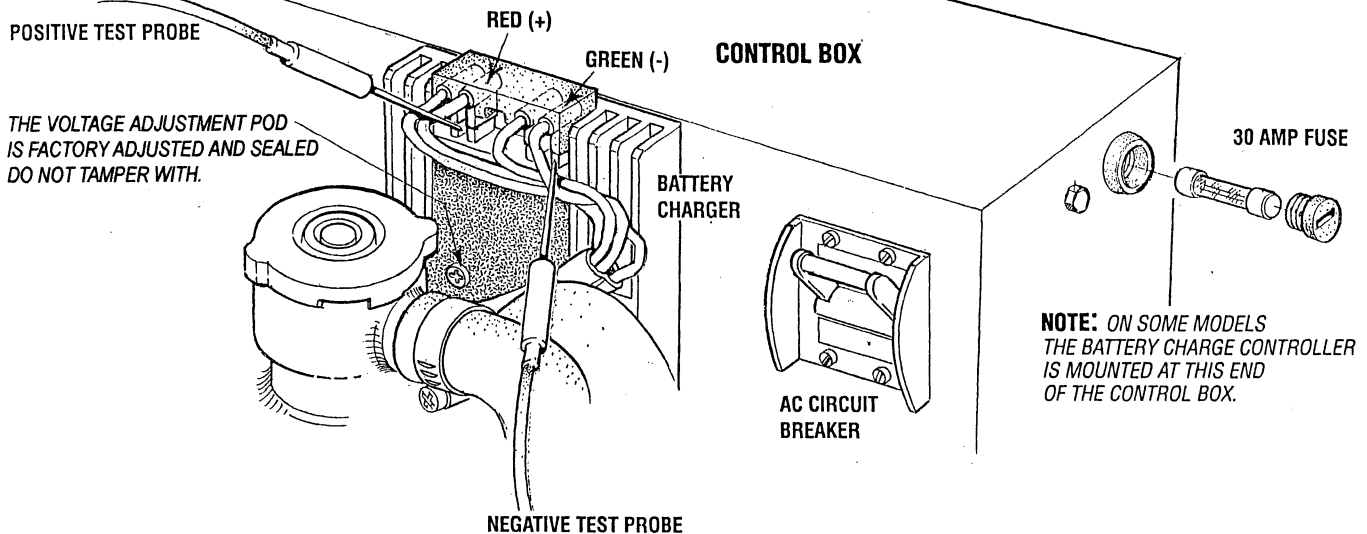

## Testing the Battery Charger

To test the battery charger, put a multimeter between the positive (+) and negative (-) leads to the battery. It should indicate 13.0V to 13.4V with the engine running. If only the battery voltage is indicated, check that the battery charger terminal connections are tight. With the unit running, test between the (+) and (-) on the battery charger (as illustrated) for 13.0V to 13.4V. If no charge is indicated, replace the charger.

Use of a dedicated and isolated starting battery is strongly recommended.

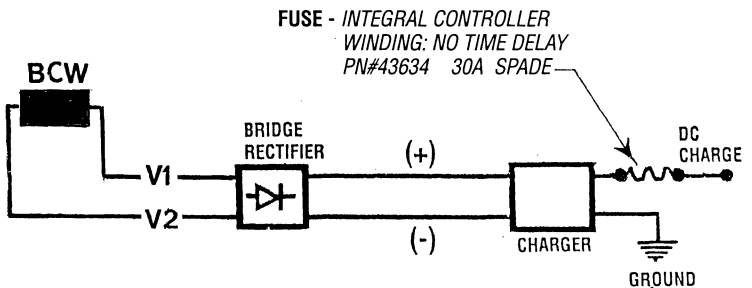
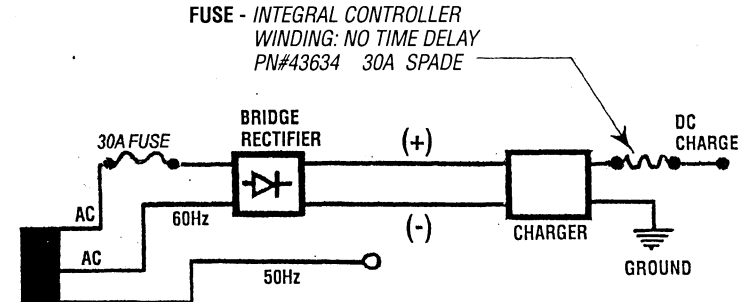



# BATTERY CHARGING CIRCUIT / BRIDGE RECTIFIER

## TESTING THE BATTERY CHARGING CIRCUIT

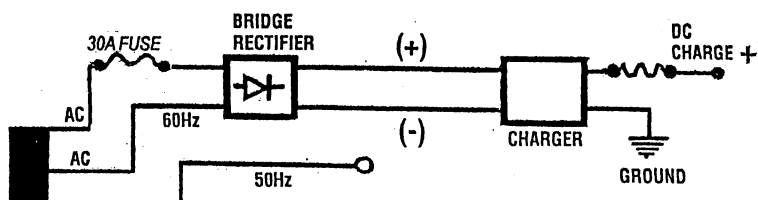

**Note:** The battery charging circuit is totally separate from the AC output of the generator. The generator output affects the circuit's output, but not the reverse.

Normal AC voltage running to the rectifier (while the engine is operating at its rated RPM) is measured across the two AC connections on the bridge rectifier (shown below).

### AC VOLTAGE TO THE BRIDGE RECTIFIER (APPROXIMATELY)

NO-LOAD OFF THE GENERATOR	16.0 VOLTS AC
FULL-LOAD OFF THE GENERATOR	17.5 VOLTS AC

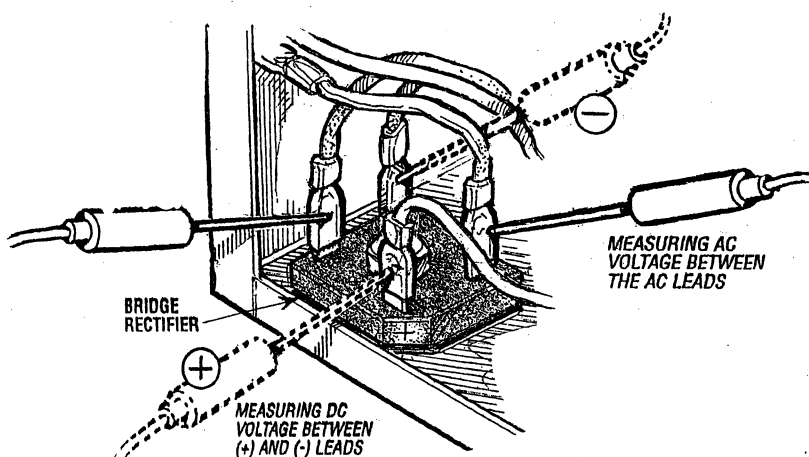

Normal DC voltage running out of the rectifier (in volts DC) is measured across the two DC connections of the bridge rectifier, that is + and - as illustrated.

### DC VOLTAGE FROM THE BRIDGE RECTIFIER (APPROXIMATELY)

NO-LOAD OFF THE GENERATOR	17.0 VOLTS DC
FULL-LOAD OFF THE GENERATOR	18.5 VOLTS DC

## CHECKING THE AC WINDING

Lift the two AC leads off the bridge rectifier. Measure the resistance between the #50 and the AC and the #60 and the AC.

### RESISTANCE

#50 TO AC	0.4 Ohm
#60 TO AC	0.3 Ohm

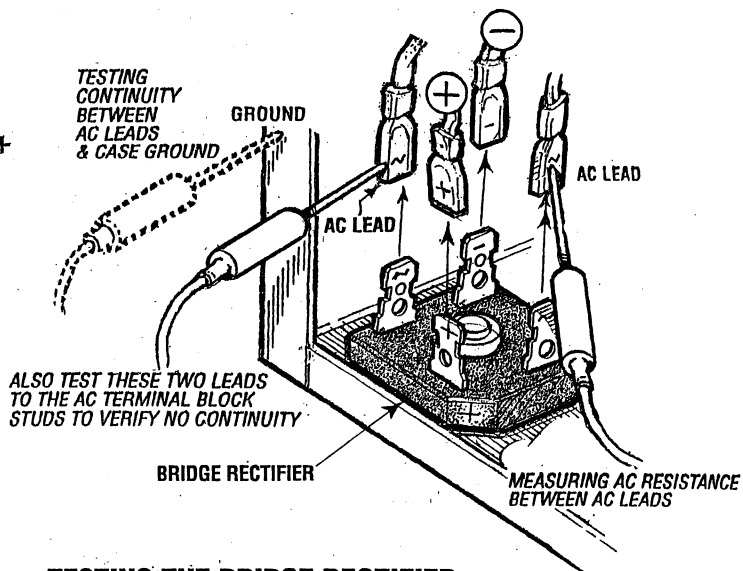

## TESTING THE BRIDGE RECTIFIER

(meter used - FLUKE multimeter)

- Set the meter on Ohms scale.
- Connect the positive (+) lead from the meter to point #4. Taking the negative (-) lead, momentarily touch points #1, #2, #3, and #5. There should be no Ohm value registered on the meter.
- Remove the positive (+) lead from point #4 and connect the negative (-) lead to it. Momentarily touch points #1, #2 and #3. The Ohm meter should register an arbitrary Ohm value at each point it touches.
- Leaving the negative (-) lead on point #4, touch point #5 with the positive (+) lead. The meter should register no Ohm value.
- Place the positive (+) lead on point #1 and the negative (-) lead on point #3. The meter again should register no Ohm value. Reverse these connections and the meter should register no Ohm value.

If the rectifier fails any of the previous tests B through E, replace the rectifier as it is defective.

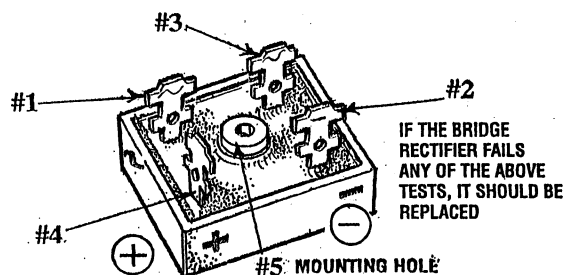

THE AC/DC PIN LOCATIONS MAY VARY ON SOME BRIDGE RECTIFIERS

### BRIDGE RECTIFIER

# 7.0KW BCGC/BCGD GENERATOR SPECIFICATIONS

## ENGINE SPECIFICATIONS

Engine Type	3-cylinder, 4-cycle, overhead camshaft w/counterbalance shaft, water cooled gasoline engine
Bore & Stroke	2.56 x 2.61 inches (65.0 x 66.3 mm)
Total Displacement	40.3 cubic inches (0.66 liters)
Bearings	Four main bearings
Compression Chamber	Semi-spherical
Compression Ratio	9.8:1
Hp@1800/1500 rpm	8.0/6.5
Firing Order	1 - 3 - 2
Aspiration	Naturally aspirated
Direction of Rotation	Counterclockwise viewed from the back end
Inclination	25° continuous, all directions
Governor	Electronic

## FUEL SYSTEM

Fuel Pump	Electric fuel pump
Fuel	Unleaded 89 octane or higher E10 blend maximum
Distributor	Breakerless distributor
Spark Plugs	14mm
Ignition Coil	12 volt
Flame Arrester	Metal screen type
Carburetor	Single draft type
Fuel Consumption (Full Load)	.8 GPH @ 1800 rpm
Fuel Filter (on engine)	Replaceable cartridge Canister Type

## ELECTRICAL SYSTEM

Start Motor	12 volt reduction gear with solenoid
Start Battery	12 Volt, (-) negative ground Battery must be totally dedicated to the generator and maintained only by the DC charge controller in the AC generator
Cranking Amp Draw	105 Cold Cranking Amps (CCA)
Battery Charging	Integral electric, 12 amps
Battery Capacity	600 - 800 CCA

## EXHAUST EMISSIONS SYSTEM

EM	Engine Modification
----	---------------------

## COOLING SYSTEM

General	Fresh water-cooled block through raw water-cooled heat exchanger circuit
Fresh Water Pump	Centrifugal type, metal impeller, belt-driven.
Raw Water Pump	Positive displacement, rubber impeller, belt-driven.
Raw Water Flow, (measure before discharge into exhaust elbow).Approx.	4.9 US gpm @ 1800 rpm
Cooling Water Capacity	3 qts (2.8 liters).
Operating Temperature	150° - 170° F (65° - 77° C)

## LUBRICATION SYSTEM

Type	Forced lubrication by gear pump.
Oil Filter	Full flow, paper element. spin-on disposals.
Oil Capacity	2.5 qts. (2.4 liters).
Operating Oil Pressure	40 - 60 psi (2.8 - 4.2 kg/cm <sup>2</sup> ).
Oil Grade	API Specification SJ class or better. SAE 40W only

## AC GENERATOR (Single Phase)

Single Phase	Brushless, four-pole capacitor, regulated. 1800 rpm/60Hz, 1500 rpm/50Hz
Ratings: 7.0KW	120 volts, 58.3 amps, 60Hz single phase, 2 wire, 1.0 power factor
5.9KW	230 volts, 25.2 amps, 50Hz single phase, 2 wire, 1.0 power factor

## TUNE-UP SPECIFICATIONS

Spark Plug Gap	0.28 - 0.31in (0.7-0.8mm)
Spark Plug Torque	10-15lb-ft (1.5=2.31kg-m)
Cylinder Head Torque	60-70 Nm (43-51 ft-lbs)
Bolt Torque	See <i>TORQUING THE CYLINDER HEAD</i>
Ignition Timing	15° BTDC @ 1800 rpm ± 1°

## AIR REQUIREMENTS

Generator Cooling	225 -250 CFM (6.3 - 7.0 cmm)
Engine Combustion (all models)	22.9 CFM (0.6 cmm)
Engine Cooling	100 CFM (2.8 cmm)

**NOTE:** Forced ventilation must be provided to maintain the generators compartment temperature below 122° F (50° C)

# 5.0KW BCG/BCGA GENERATOR SPECIFICATIONS

## ENGINE SPECIFICATIONS

Engine Type	3-cylinder, 4-cycle, overhead camshaft w/counterbalance shaft, water cooled gasoline engine
Bore & Stroke	2.56 x 2.61 inches (65.0 x 66.3 mm)
Total Displacement	40.3 cubic inches (0.66 liters)
Bearings	Four main bearings
Compression Chamber	Semi-spherical
Compression Ratio	9.8:1
Hp@1800/1500 rpm	8.0/6.5
Firing Order	1 - 3 - 2
Aspiration	Naturally aspirated
Direction of Rotation	Counterclockwise viewed from the back end
Inclination	25° continuous, all directions
Governor	Electronic

## FUEL SYSTEM

Fuel Pump	Electric fuel pump
Fuel	Unleaded 89 octane or higher E10 blend maximum
Distributor	Breakerless distributor
Spark Plugs	14mm
Ignition Coil	12 volt
Flame Arrester	Metal screen type
Carburetor	Single draft type
Fuel Consumption (Full Load)	.8 GPH @ 1800 rpm
Fuel Filter (on engine)	Replaceable cartridge Canister Type

## ELECTRICAL SYSTEM

Start Motor	12 volt reduction gear with solenoid
Start Battery	12 Volt, (-) negative ground Battery <b>must</b> be totally dedicated to the generator and maintained only by the DC charge controller in the AC generator
Cranking Amp Draw	105 Cold Cranking Amps (CCA)
Battery Charging	Integral electric, 17 amps
Battery Capacity	600 - 800 CCA

## EXHAUST EMISSIONS SYSTEM

EM	Engine Modification
----	---------------------

## COOLING SYSTEM

General	Fresh water-cooled block through raw water-cooled heat exchanger circuit
Fresh Water Pump	Centrifugal type, metal impeller, belt-driven.
Raw Water Pump	Positive displacement, rubber impeller, belt-driven.
Raw Water Flow, (measure before discharge into exhaust elbow).Approx.	4.9 US gpm @ 1800 rpm
Cooling Water Capacity	3 qts (2.8 liters).
Operating Temperature	150° - 170° F (65° - 77° C)

## LUBRICATION SYSTEM

Type	Forced lubrication by gear pump.
Oil Filter	Full flow, paper element. spin-on disposals.
Oil Capacity	2.5 qts. (2.4 liters).
Operating Oil Pressure	40 - 60 psi (2.8 - 4.2 kg/cm <sup>2</sup> ).
Oil Grade	API Specification SJ class or better. SAE 40W only

## AC GENERATOR (Single Phase)

Single Phase	Brushless, four-pole capacitor, regulated. 1800 rpm/60Hz, 1500 rpm/50Hz
Ratings:	
5.0KW	120 volts, 41.6 amps, 60Hz single phase 2 <i>wire</i> , 1.0 power factor
4.2KW	230 volts, 18.2 amps, 50Hz single phase 2 <i>wire</i> , 1.0 power factor

## TUNE-UP SPECIFICATIONS

Spark Plug Gap	0.28 - 0.31in (0.7-0.8mm)
Spark Plug Torque	10-15lb-ft (1.5=2.31kg-m)
Cylinder Head Torque	60-70 Nm (43-51 ft-lbs)
Bolt Torque	See <i>TORQUING THE CYLINDER HEAD</i>
Ignition Timing	15° BTDC @ 1800 rpm ± 1°

## AIR REQUIREMENTS

Generator Cooling	225 -250 CFM (6.3 - 7.0 cmm)
Engine Combustion (all models)	22.9 CFM (0.6 cmm)
Engine Cooling	100 CFM (2.8 cmm)

**NOTE:** Forced ventilation must be provided to maintain the generators compartment temperature below 122° F (50° C)

# BC GENERATOR SINGLE PHASE

## DESCRIPTION

The BC generator is a brushless, self-excited generator, which requires only the driving force of the engine to produce an AC output. The stator houses two sets of windings; the main stator windings and the exciter windings. When the generator is started, residual magnetism in the four rotating poles induces a voltage in the stator which then generates an even larger voltage in the exciter windings. This mutual build up of voltage in the four rotating poles and in the exciter windings quickly reaches the saturation point of the capacitor(s) and a regulated energy field is then maintained in the stator. At the same time, this regulated field produces a steady voltage in the stator windings which can then be drawn off the generator's AC terminals to operate AC equipment. The generator is a single-phase, reconnectable 120 volt AC two-wire or 115 volt AC two-wire or 230 volt AC two-wire, at 50 hertz.

The generator's data plate gives the voltage, current and frequency rating of the generator. An AC wiring decal is affixed to the inside of the louvered cover at the generator end. A diagram of the various AC voltage connections is provided on the decal. An Integral Controller (IC) is mounted inside the generator and supplies a continuous DC charge to the generators starting battery when the generator is running.

**Winding Connections:** The single-phase synchronous generator has 4 stator leads and can be configured to 120 volt 60 hertz; or 230 volt AC two-wire, at 50 hertz.

**Bearings:** The bearings are sealed type and permanently greased requiring no maintenance during their working life (approx. 30,000 hours).

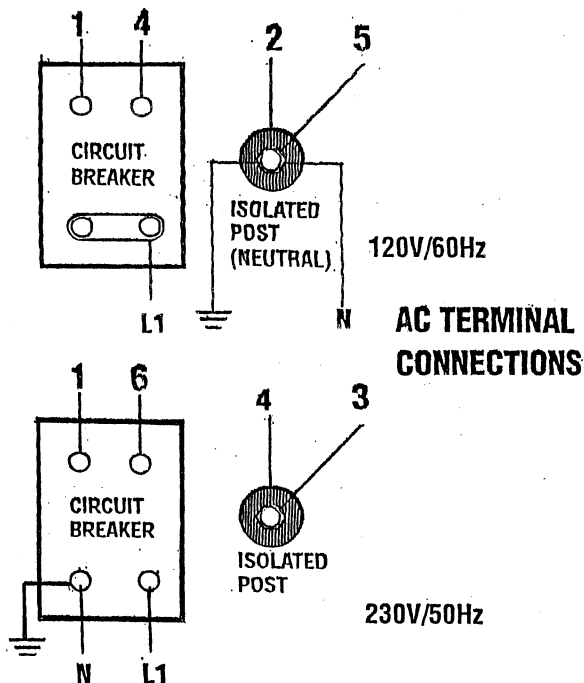

**NOTE:** Correctly position the case ground wire (white/green) onto the neutral/ground terminal.

## MOTOR DATA

The power required to start an electric motor is considerably more than is required to keep it running after it is started. Some motors require much more current to start them than others. Split-phase (AC) motors require more current to start, under similar circumstances, than other types. They are commonly used on easy-starting loads, such as washing machines, or where loads are applied after the motor is started, such as small power tools. Because they require 5 to 7 times as much current to start as to run, their use should be avoided, whenever possible, if the electric motor is to be driven by a small generator. Capacitor and repulsion-induction motors require from 2 to 4 times as much current to start as to run. The current required to start any motor varies with the load connected to it. An electric motor connected to an air compressor, for example, will require more current than a motor to which no load is connected.

In general, the current required to start 115-Volt motors connected to medium starting loads will be approximately as follows:

MOTOR SIZE (HP)	AMPS FOR RUNNING (AMPERES)	AMPS FOR STARTING (AMPERES)
1/6	3.2	6.4 to 22.4*
1/4	4.6	9.2 to 32.2*
1/3	5.2	10.4 to 72.8*
1/2	7.2	14.4 to 29.2*
3/4	10.2	20.4 to 40.8*
1	13	26 to 52

**\*NOTE:** In the above table the maximum Amps for Starting is more for some small motors than for larger ones. The reason for this is that the hardest starting types (split-phase) are not made in larger sizes.

Because the heavy surge of current needed for starting motors is required for only an instant, the generator will not be damaged if it can bring the motor up to speed in a few seconds. If difficulty is experienced in starting motors, turn off all other electrical loads and, if possible, reduce the load on the electric motor.

## Generator Maintenance

Maintaining reasonable cleanliness is important. Connections of terminal boards and rectifiers may become corroded, and insulation surfaces may start conducting if salts, dust, engine exhaust, carbon, etc. are allowed to build up. Clogged ventilation openings may cause excessive heating and reduced life of windings.

In addition to periodic cleaning, the generator should be inspected for tightness of all connections, evidence of overheated terminals and loose or damaged wires.

# BC GENERATOR SINGLE PHASE

## GENERATOR OUTPUT

To confirm the generator's output capacity, run the generator first with no-load, then at half capacity, and finally load it to full capacity (indicated on the generator's data plate). Voltage and load can be monitored using a portable meter and amp probe. The output should be checked periodically to ensure proper operation of the generator and the appliances it supplies.

## ROTATING FIELD/AUXILIARY WINDINGS

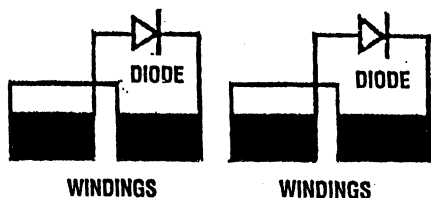

Two sets of windings are found in the rotor assembly. An AC voltage is produced in two groups of windings as the rotor turns at its rated rpm. This AC voltage passes through each of the two diodes mounted on the isolated fixture just before the rotor carrier bearing. The AC sine wave is changed to DC and this DC voltage is passed through the two groups of rotating field windings producing a DC field around these windings. This field affects the AC winding of the two main stator groups inducing an AC voltage in these windings that is available at the AC terminal block connections.

## AC CIRCUIT BREAKER

An AC circuit breaker is installed on all single phase generators. This AC circuit breaker will automatically disconnect the generator's output from the vessel's AC load in the event of an amperage overload. In the event of an AC breaker tripping it must be manually reset. **The AC breaker can be manually opened when servicing the generator/engine to ensure no AC voltage is sent to the vessel's distribution panel when operating the unit.**

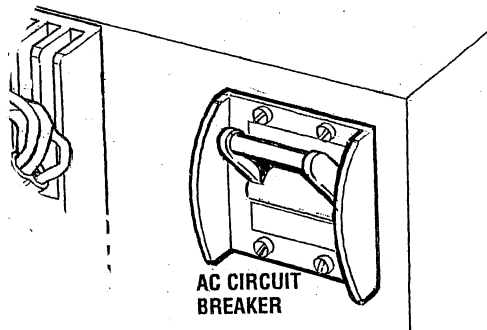

## INTRODUCTION TO TROUBLESHOOTING

The following test procedures can be used to troubleshoot *WESTERBEKE'S 4 POLE DUAL EXCITER CIRCUIT BRUSHLESS GENERATORS*. Due to the simplicity of the generator, troubleshooting is relatively easy.

Field testing and repairing can be accomplished with basic tools and repair parts which should include the following:

**A quality multimeter (multitester)** capable of reading less than one ohm and with a specific diode testing function.

**Basic electrical tools** including cutters, soldering iron, wire strapper/crimper, terminal connectors, etc.

**Repair parts** such as diodes, fuses, bridge rectifier, etc.

## PRELIMINARY CHECKING

Before electrical testing, check for proper engine speed/hertz adjustment. Low engine speed will cause low AC voltage output, high engine speed-high AC output.

Refer to *WESTERBEKE'S* operators manual or service manual for engine speed/hertz adjustment or for other possible engine related problems.

Before testing, get a clear explanation of the problem that exists, be certain it relates to generator components.

# BC GENERATORS TROUBLESHOOTING CHART

A, B, C, & D refer to the components of the *INTERNAL WIRING DIAGRAM* and their test procedures in the following pages.

**NOTE:** This fault finding chart is compiled assuming the engine is operating at the correct speed/hertz.

## WINDING RESISTANCE VALUES (OHMS)

	5.0KW	6.5KW
<b>MAIN STATOR:</b>		
<b>#1 TO #3</b>	0.4	0.2
<b>#4 TO #6</b>	0.4	0.2
<b>ROTOR: (Each pair)</b>	4.0	2.0
<b>EXCITER: (Each winding)</b>	3.9	2.5
<b>CHARGE WINDING:</b>	0.4	0.4 (#50-AC)

## INTERNAL WIRING SCHEMATIC

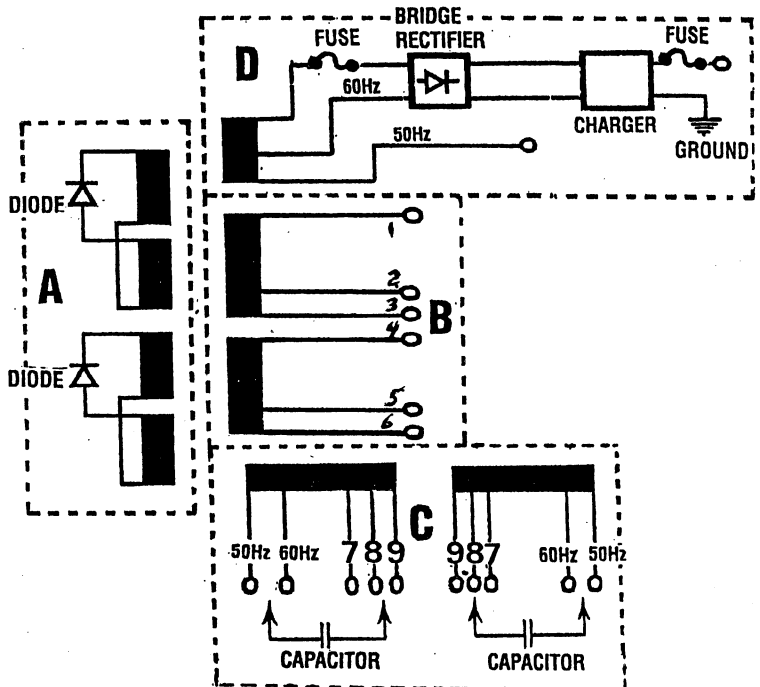

- A** - ROTOR WINDINGS
- B** - STATOR WINDINGS
- C** - CAPACITOR WINDING
- D** - BATTERY CHARGE WINDING

FAULT	CAUSE	TEST/CORRECTION
No AC Output	Shorted stator	<b>B</b>
	Open stator	<b>B</b>
	Shorted diode (two)	<b>A</b>
Residual Voltage 4-6 VAC (Hot N) at No-Load	Faulty capacitor (two)	<b>C</b>
	Open exciter	<b>B</b>
	Shorted exciter	<b>B</b>
	Engine speed (hertz) is too low	Correct *
	Electrical connections are faulty	Inspect wiring connections
High AC Output at No-Load	Incorrect voltage tap on capacitor	<b>C</b>
	Incorrect capacitor	<b>C</b>
	Incorrect hertz tap on capacitor	<b>C</b>
	Engine speed (hertz) too high.	Correct *
Low AC Output 60-160V	Faulty rotor winding	<b>A</b>
	Faulty diode	<b>A</b>
	Faulty capacitor	<b>B</b>
Voltage Drop Under Load (or at No-Load)	Faulty diode	<b>A</b>
	Faulty capacitor	<b>C</b>
	Engine speed (hertz) is too low	Correct *
No Battery Charge Low Battery Charge	Faulty Bridge rectifier	<b>D</b>
	Faulty integral controller	<b>D</b>
	Blown fuse (s)	<b>B</b>
	Faulty wiring	<b>B</b>
High Voltage Output when Load is applied	Engine speed (hertz) is too high	Correct *
Unstable Voltage	Electrical connections are faulty, loose	Inspect wiring connections
Noisy Operation	Faulty support bearing	Inspect rear bearing**
	Generator rotor connection to engine is loose	Check rotor security**

\* Refer to the *GENERATORS OPERATOR MANUAL*

\*\* Refer to the *GENERATORS SERVICE MANUAL*

# TESTING THE BC ROTOR

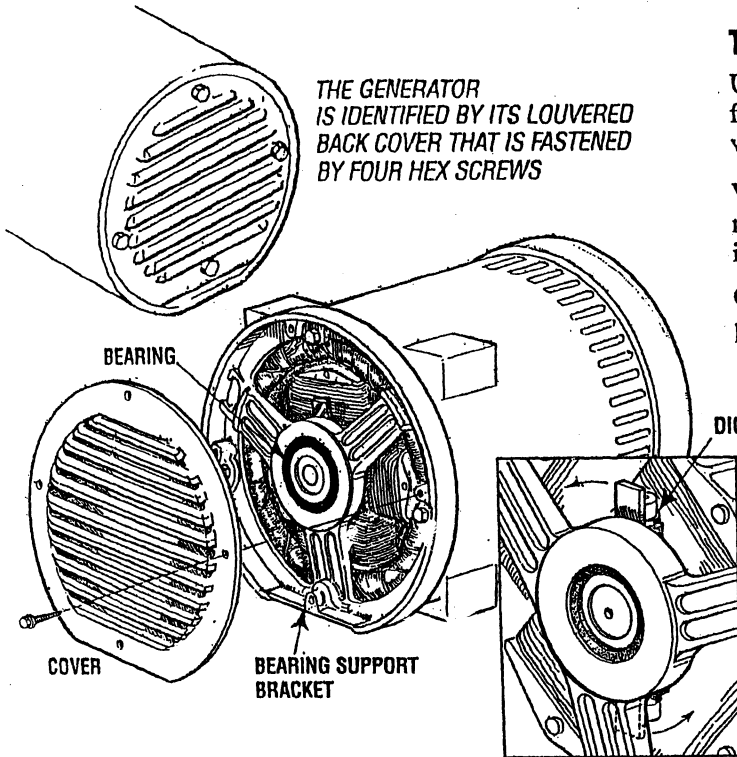

Testing the generator can be accomplished without removing the bearing support bracket. Simply turn the armature to allow access for the testing as shown.

## TESTING THE WINDINGS THROUGH THE DIODES

Rotate the armature into position to access a diode. To make a quick test of the windings, assume the diode to be OK and test the connection at each end of the diode. Turn the armature and test the other side.

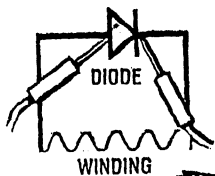

**ROTATING FIELD/AUXILIARY WINDING RESISTANCE VALUE**  
**4.0 OHM**

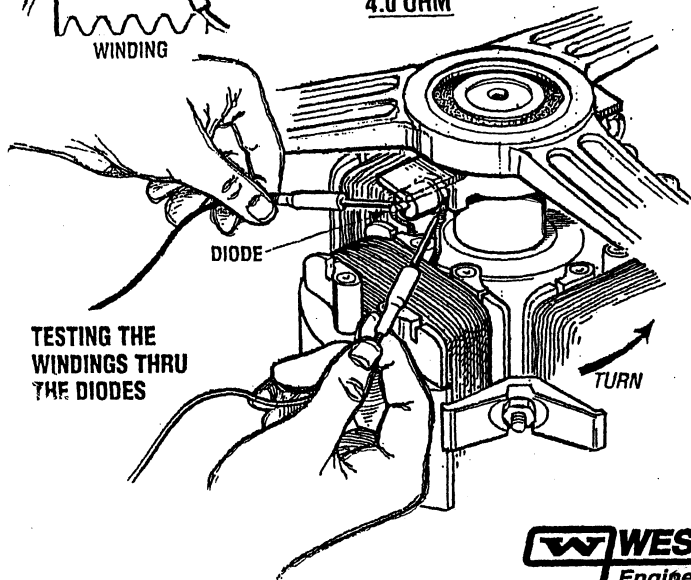

**TESTING THE WINDINGS THROUGH THE DIODES**

## TESTING THE ROTOR FIELD WINDINGS

Unsolder the winding connection from the diode and carefully remove the diode from its isolated heat sink using a thin walled, deep well 7/16" (11mm) socket.

With the diode removed, both leads for the first group of rotating field/auxiliary windings will be isolated with no interference from a possibly faulty diode.

Check the resistance value of the rotating windings by placing an ohmmeter's probes across the two exposed leads.

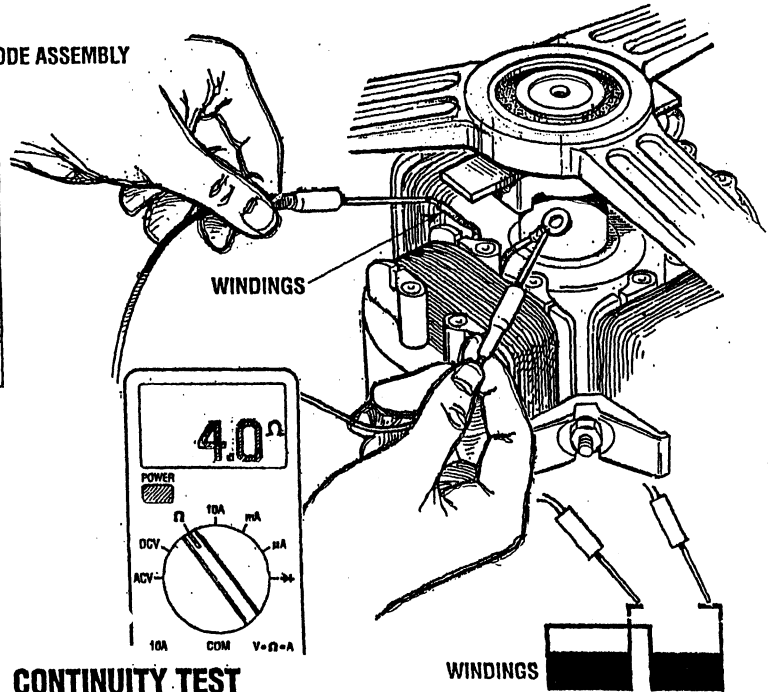

## CONTINUITY TEST

Check that no continuity exists between either of the winding leads and the generator shaft. If continuity is found, there is a short in the windings.

Repeat these tests on the second set of windings on the opposite side.

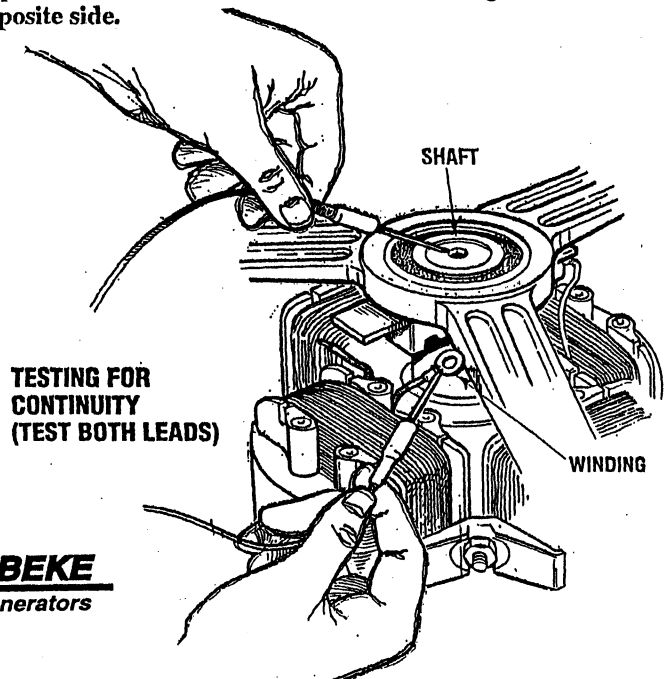

**TESTING FOR CONTINUITY (TEST BOTH LEADS)**

# BC GENERATORS TROUBLESHOOTING CHART COLISEUM MODEL

(REFER TO THE WIRING SCHEMATIC)

FAULT	CAUSE	TEST
NO AC VOLTAGE OUTPUT	1. Shorted stator 2. Open stator 3. Rotor diode open/shorted	1. W1 & W2 2. W1 & W2 3. D1 & D2
RESIDUAL VOLTAGE 3-4 VAC LINE TO N AT NO LOAD	1. Faulty capacitor 2. Open exciter winding 3. Shorted exciter 4. Engine speed low 5. Electrical connection	1. C1 2. EW1 - EW2 3. EW1 - EW2 4. Adjust 5. Inspect
HIGH AC OUTPUT AT NO LOAD	1. Engine speed too high 2. Capacitor connection	1. Adjust 2. Correct
LOW AC OUTPUT 60-100 VAC	1. Faulty rotor winding 2. Faulty diode (shorted) 3. Faulty capacitor 4. Faulty exciter windings	1. RW 2. D1 or D2 3. Check rating 4. Check windings
VOLTAGE DROP UNDER LOAD	1. Faulty diode 2. Engine speed low 3. Faulty capacitor	1. D1 or D2 2. Check/adjust 3. Check rating
HIGH VOLTAGE OUTPUT (NO LOAD/LOADED)	1. Engine speed	1. Check/adjust
UNSTABLE OUTPUT	1. Electrical connection 2. Engine speed	1. Check 2. Check/adjust

## POTENTIAL BC PROBLEMS

### Diodes

1. An open diode will cause the loss of any rotating field.
2. A shorted diode will weaken the rotating field.

### Field Windings

1. An open field winding will cause the loss of the rotating field.
2. A shorted field winding will cause a weak rotating field.
3. Test each diode individually. A resistance value should be found through the diode in one direction and, with the meter probes reversed, show no ohm value.

## GENERATOR WINDING SCHEMATIC

**NOTES:** For 60Hz operation: Connect capacitors to E31-E41 and to E11-E21.

For 50Hz operation: Connect capacitors to E31-E42 and E11-E22.

EW1-Exciter Windings 1  
EW2-Exciter Windings 2  
BCW-Battery charging windings  
RW-Rotor Winding

W1-Stator Winding 1  
W2-Stator Winding 2  
C-Capacitor  
D1/D2-Diodes

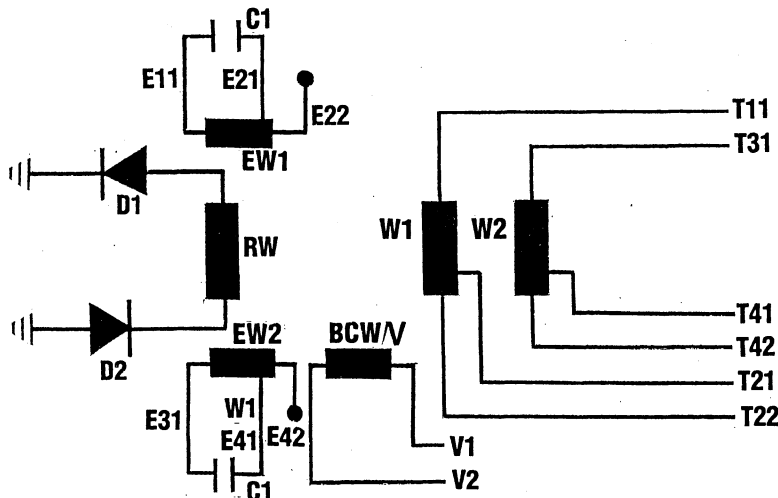

**RESIDUAL VOLTAGE TEST** (unit operating at rated hertz)  
Exciter circuit capacitor disconnected from exciter windings

**MAIN STATOR RESIDUAL VOLTAGE** (Live to neutral)  
3-4 VAC

### EXCITER WINDING GROUP

EW1	E31-E42	5-6 VAC
EW2	E11 to E22	5-6 VAC

**NOTE:** The presence of correct residual voltage is an indication the winding is O.K. (main stator or exciter windings).

### WINDING RESISTANCE VALUES (OHMS)

	5.0KW	7.0KW
<b>EXCITER WINDINGS:</b>		
EW1 (E11 & E22)	3.4	2.2
EW2 (E31 & E42)	3.4	2.2
<b>BATTERY CHARGING:</b>		
BCW	0.5	0.5
<b>STATOR WINDINGS:</b>		
W1 (T11 & T22)	0.6	0.9
W2 (T31 & T42)	0.6	0.9
<b>ROTOR WINDINGS:</b>		
RW	1.7	2.2



# TESTING THE BC ROTOR COLISEUM MODEL

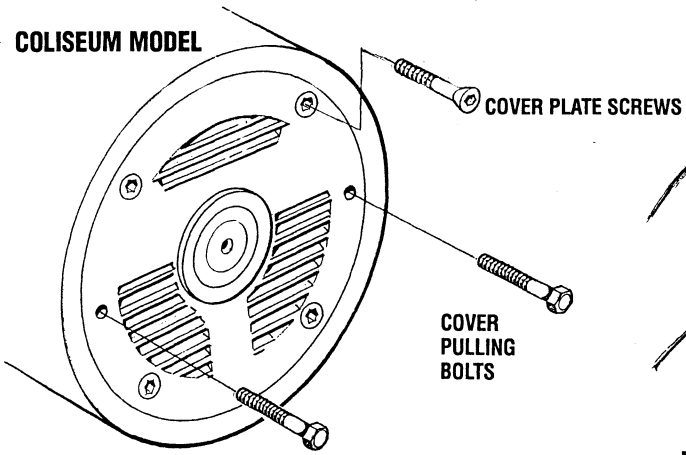

## REMOVE THE COVER PLATE

1. Remove the four cover plate screws.
2. Insert two 8mm x 35mm-1.25 pitch bolts into the two left and right vacant holes as shown.
3. Tighten these two bolts in sequence. This will pull the cover plate off the generator, exposing the rotor assembly with the bearing in place.
4. When re-installing, place a small amount of petroleum jelly on the rotor bearing "O" ring located in the cover boss.

Position the cover onto the bearing and thread the allen head screws back into place finger tight).

Tighten the screws in a criss-cross manner drawing the end cover onto the bearing. When fully on, tighten the screws securely.

## TESTING THE ROTOR FIELD WINDINGS

Use a thin walled, deep well 7/16" (11mm) socket and remove the diodes from the isolated plate. With the winding connection still attached to the diode test between the connection and the metal of the rotor shaft as shown above, check both sides.

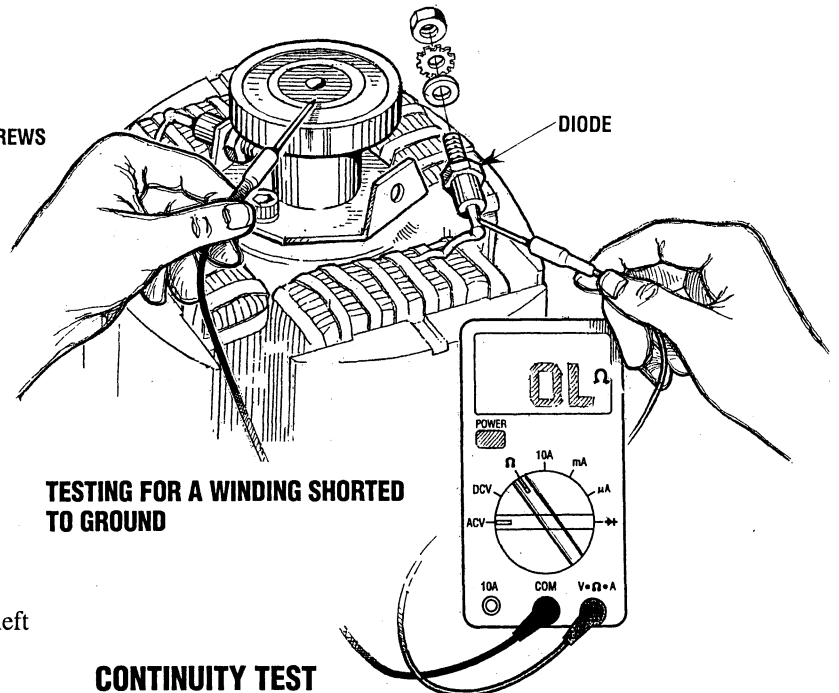
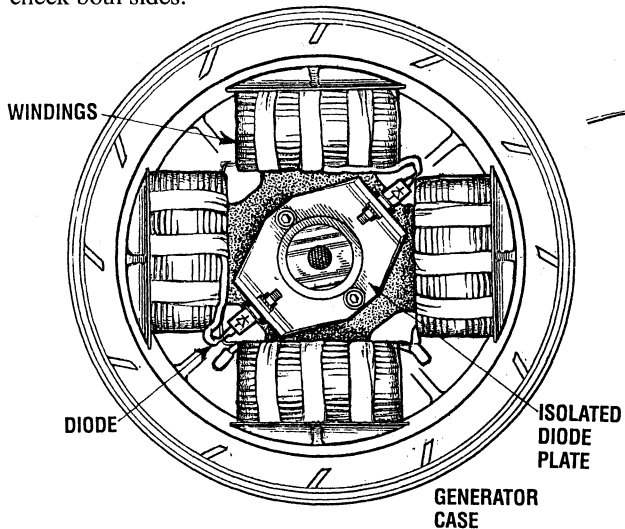

## TESTING FOR A WINDING SHORTED TO GROUND

### CONTINUITY TEST

With the diode still removed from the isolated plate, test the continuity between the winding/diode connection and the generator case.

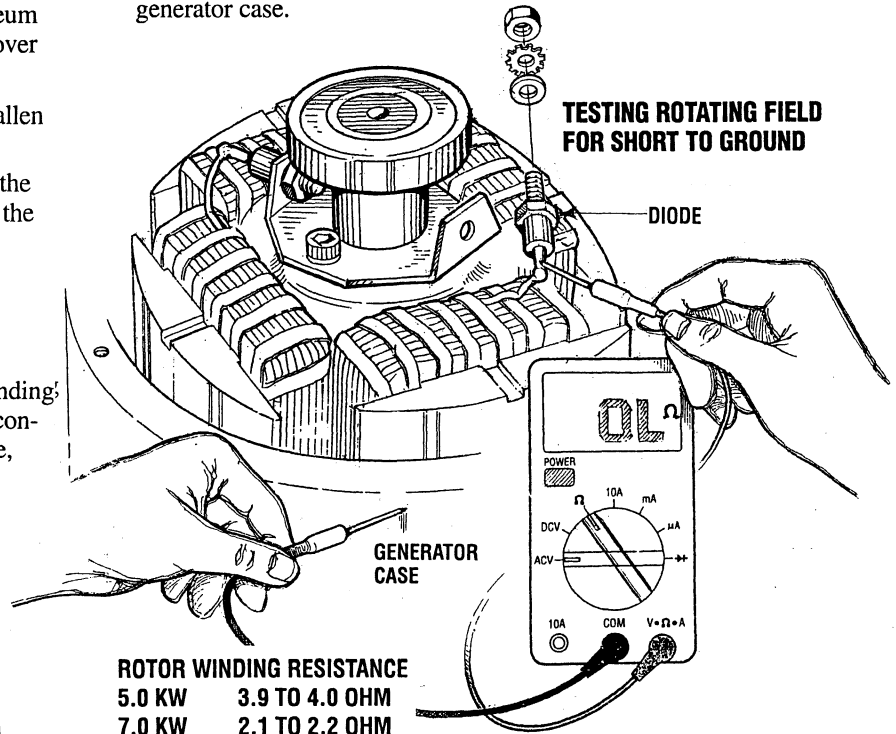

ROTOR WINDING RESISTANCE	
5.0 KW	3.9 TO 4.0 OHM
7.0 KW	2.1 TO 2.2 OHM

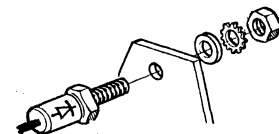
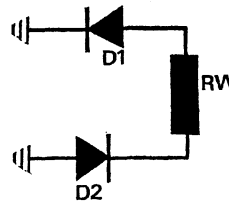

## TESTING THE DIODES

Refer to the following pages.

# TESTING THE DIODES/CONTROL PANEL

## TESTING THE DIODES - ALL MODELS

Carefully unsolder the winding connection to the diode and remove the diode using a thin walled, deep well 7/16" (11mm) socket and a box wrench as needed.

Test the diode as shown with ohmmeter leads at both ends, then reverse the positions.

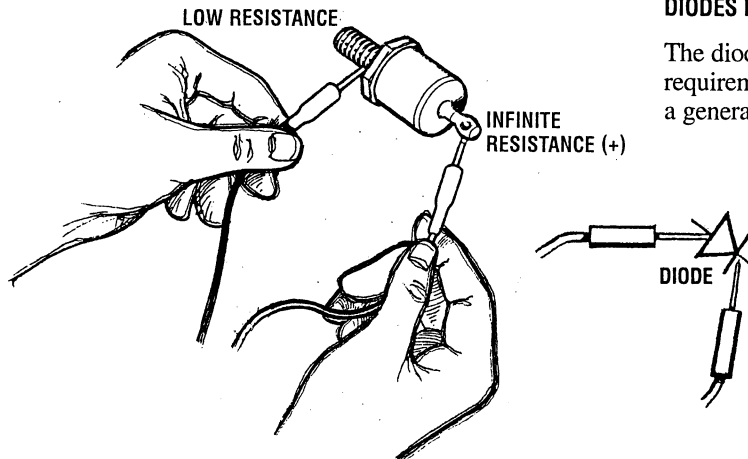

A low resistance should be found with the leads in one direction and infinite resistance (blocking) in the other direction.

**DIODES: 1.4 - 1.5 OHMS (APPROX.) USING A 260 FLUKE 76 METER.**

**NOTE:** Different meter models may show different ohm values, but should read the same for both diodes.

**DIODES RATING 1600 VOLTS 26 AMPS**

The diode's rating is far in excess of the circuit's requirements. Most likely a diode failure will result from a generator overspeed or load surge.

## CONTROL BOX / CONTROL PANEL COMPONENTS

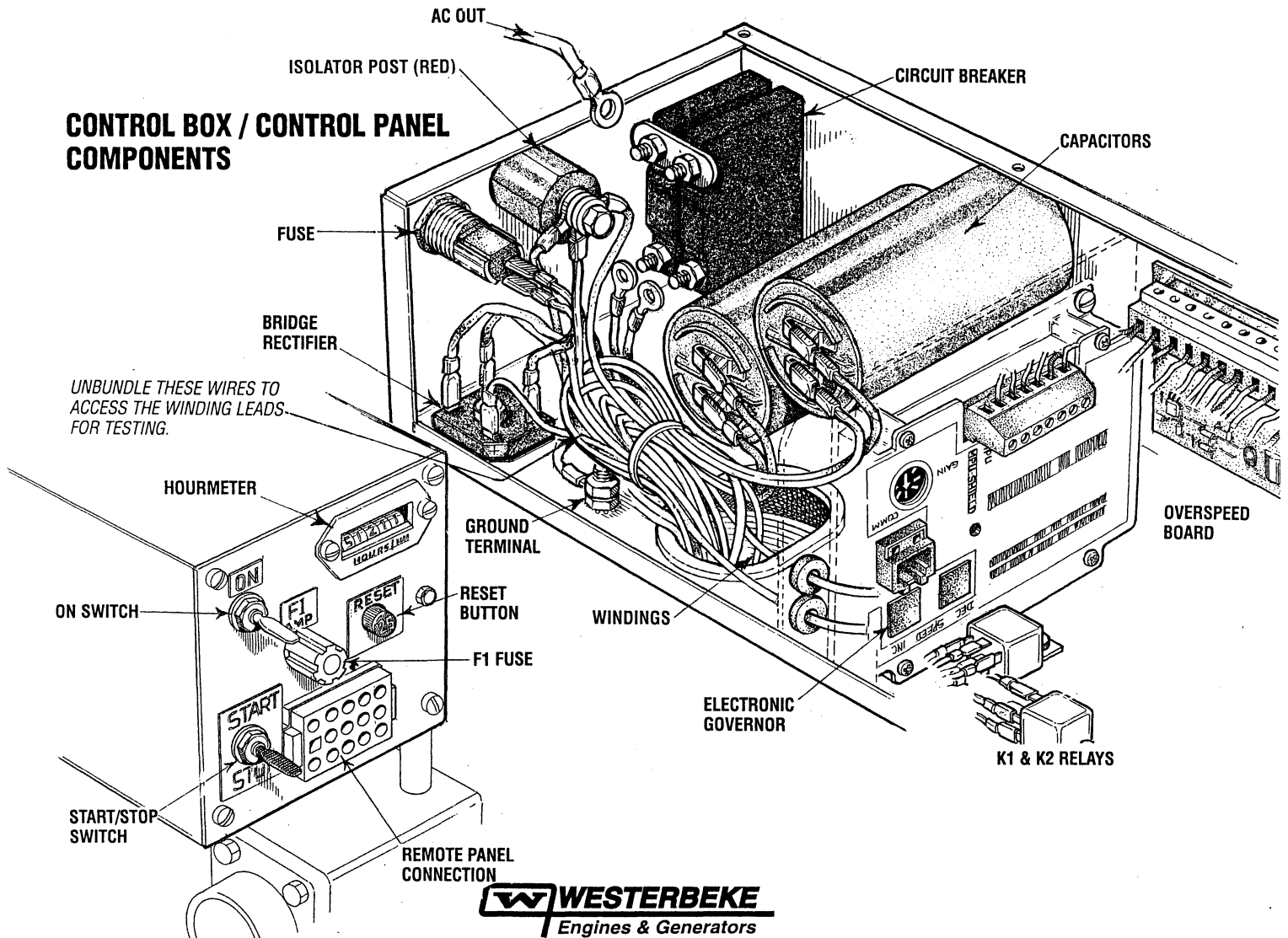

# BC GENERATORS TROUBLESHOOTING

## NO AC VOLTAGE OUTPUT

### EXCITING THE GENERATOR

To quickly determine a short or an open in the main stator winding, excite the generator with 12 VDC using one exciter winding group to accomplish this.

The AC voltage that the generator will produce measured between the line and neutral during excitation will be very low.

**NORMAL AC VOLTAGE DURING 12 VDC EXCITATION:**  
12 - 16 VOLTS AC

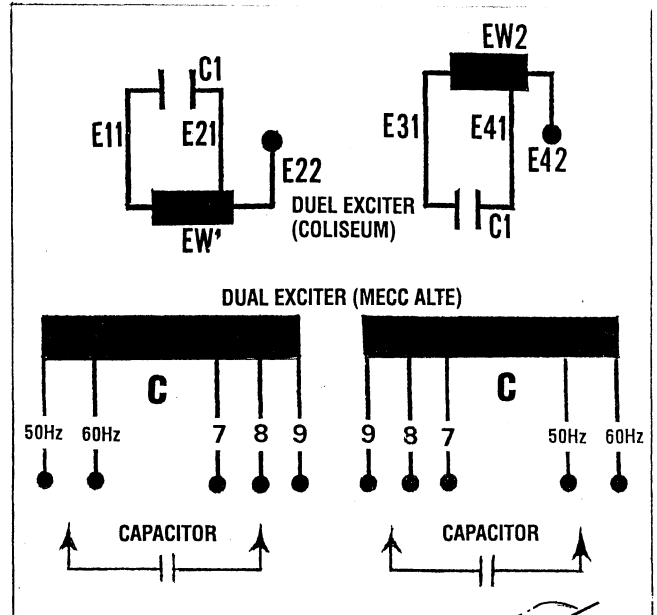
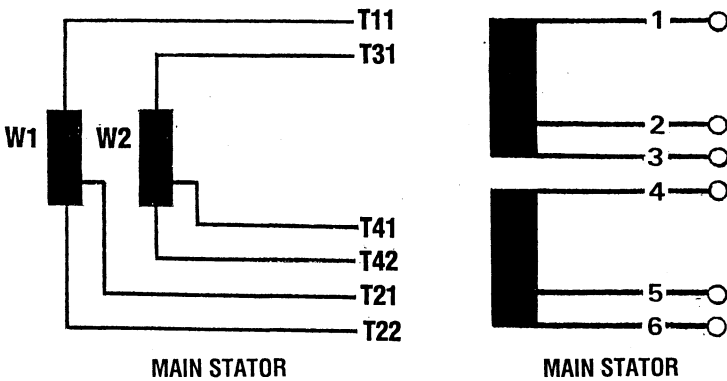

### EXCITING PROCEDURE

Locate one of the exciter winding groups in the generator. Unplug all connections from both capacitors. Connect 12 VDC across the winding using the winding end connection.

For example: Winding group EW1 between connection E11 and E22. Winding group C between #50Hz and #9.

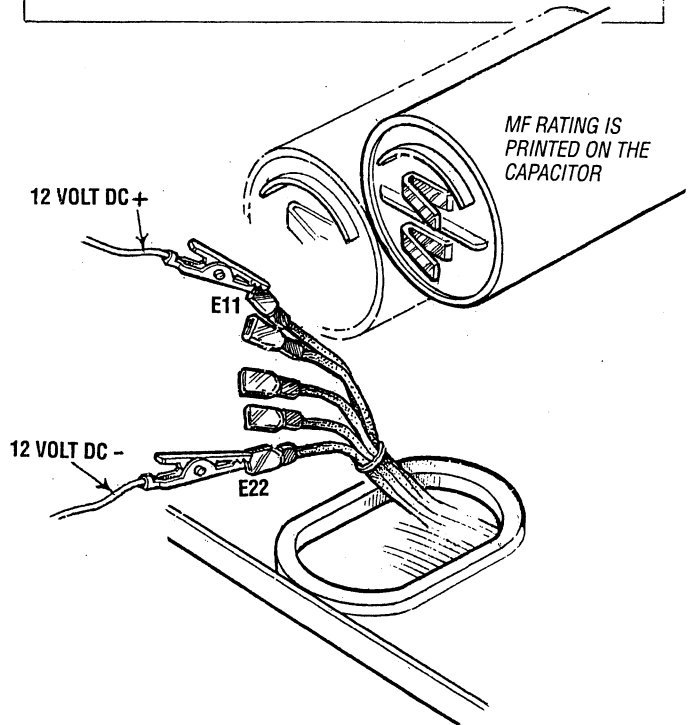

# BC GENERATORS TROUBLESHOOTING

## REACTION DURING EXCITATION

(Unit running-12VDC applied to winding)

1. A very low AC outout and loading of the drive engine and a growling noise from the generator end.

This indicates a shorted stator winding to ground or the stator windings are shorted to each other. Isolate the winding groups and verify a short to ground. No continuity should be found between the two isolated stator winding groups.

2. No reaction from the generator or drive engine. No AC output.

This is an indication of an open in one of the main stator winding groups. Isolate the winding groups and verify an open winding.

### No Continuity between Isolated Stator Windings and Ground

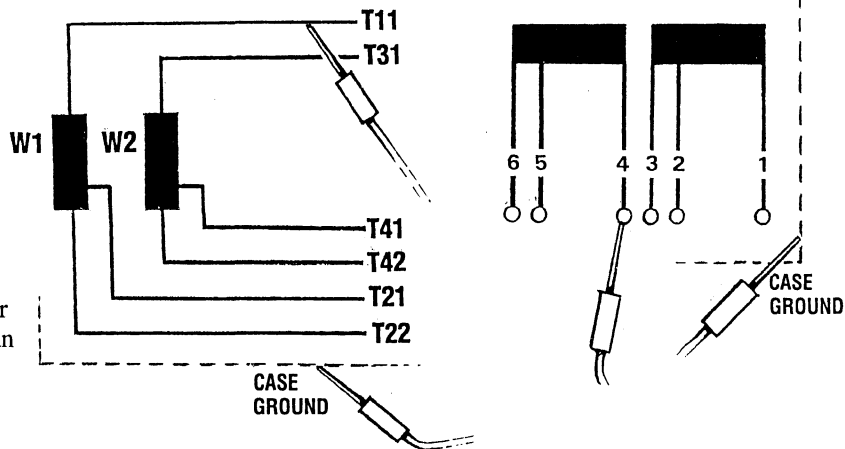

### No Continuity between Isolated Stator Winding Groups

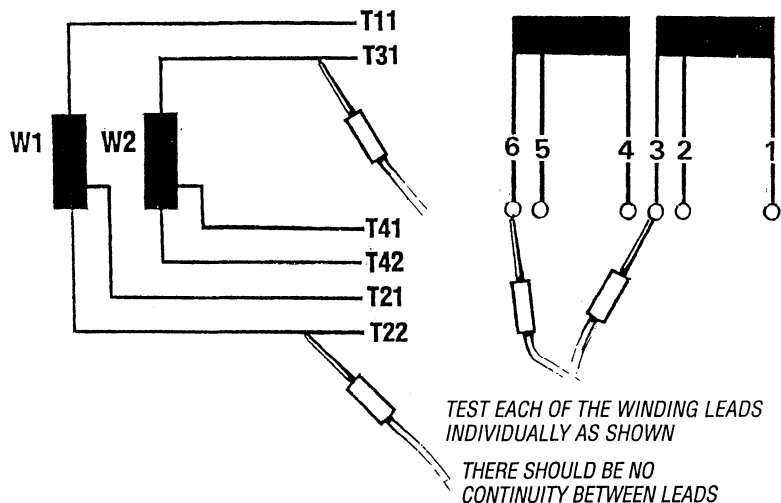

TEST EACH WINDING TO CASE GROUND

# BC GENERATORS TROUBLESHOOTING

## TESTING THE EXCITER WINDINGS

AC voltage can be measured across the capacitor electrical connections while the generator is operating. This voltage may be as high as 350 to 400 volts AC.

This AC voltage build-up is accomplished as the exciter winding for each capacitor charges the capacitor and the capacitor discharges back into the winding. This flow of saturating AC in the exciter winding produces a phase-imbalance type of field that affects the auxiliary windings of the rotor.

The AC voltage reading is taken between the two electrical connections on each separate capacitor with the generator operating at its correct no load speed.

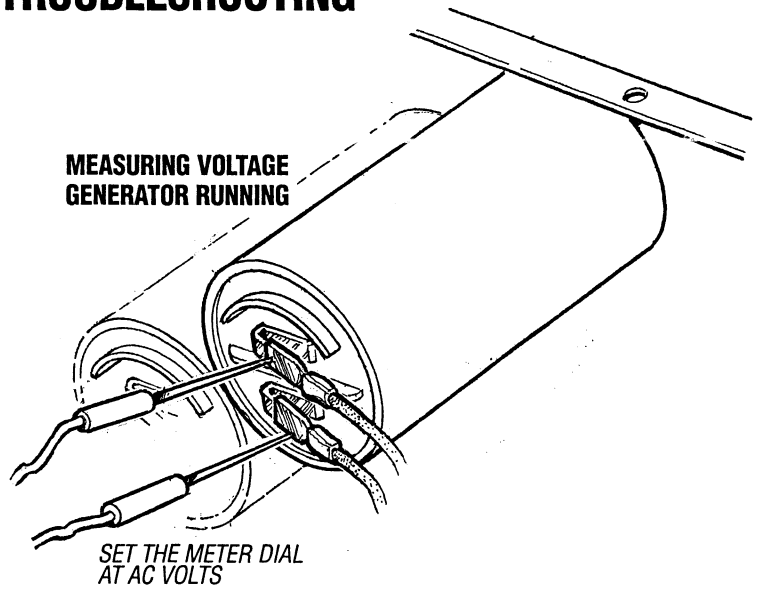

## EXCITER WINDING INTEGRITY (RESIDUAL AC VOLTAGE)

The condition of each exciter winding can be determined by the residual AC voltage each exciter winding should be producing with the generator running at proper no load speed.

To do this: Unplug all connections from the capacitor. Locate the electrical connection for each winding end. Place your AC volt meter connects across these two connections. Start the generator and observe the residual AC voltage produced by the winding. Check the other exciter winding in the same way. Residual AC voltage lower than listed below will indicate a faulty winding.

### RESIDUAL AC VOLTAGES (Each exciter winding)

- |        |                         |           |
|--------|-------------------------|-----------|
| 5.0 KW | E11 - E22 AND E31 - E42 | 5 - 6 VAC |
|        | #50 - #9 AND #50 - #9   | 7 - 9 VAC |
| 7.0 KW | E11 - E22 AND E31 - E42 | 5 - 6 VAC |
|        | #50 - #9 AND #50 - #9   | 7 - 9 VAC |

THERE SHOULD BE NO CONTINUITY BETWEEN LEADS 50HZ AND #9 TO CASE GROUNDS

MEASURE THE RESISTANCE VALUE OF THE EXCITER WINDINGS BETWEEN THE END LEADS OF EACH WINDING

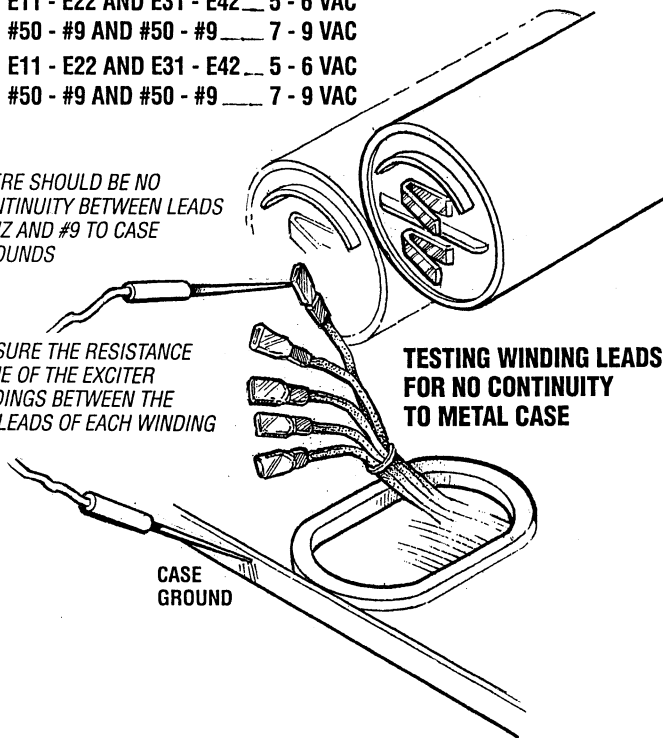

### MECCALTE MODEL

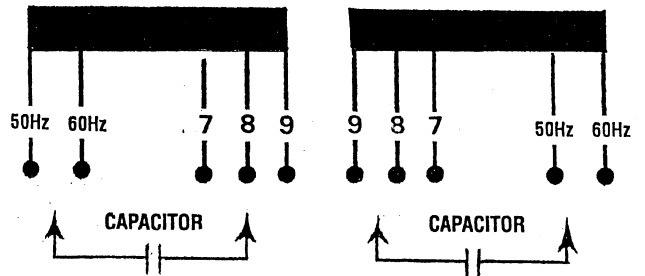

### COLISEUM MODEL

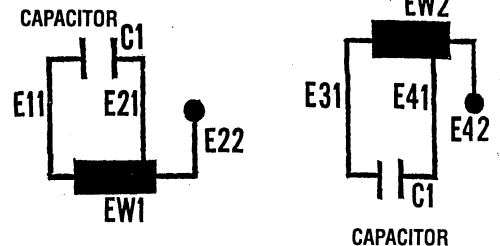

MAIN STATOR WINDING RESISTANCE  
LESS THAN ONE OHM FOR EACH WINDING GROUP

MAIN STATOR RESIDUAL VOLTAGE  
LINE TO NEUTRAL 4-6 AC VOLTS  
(THIS INDICATES GOOD STATOR WINDINGS)

# BC GENERATORS TROUBLESHOOTING

## TESTING CONTINUITY

Quick field check (no capacitance scale on meter).

Connect a digital ohm meter or analog ohm meter (high scale) to the capacitor terminals. The meter will register an arbitrary ohm value for the material in the capacitor. The meter's battery will then start to charge the capacitor and the ohm value will increase.

If the meter does not react as above, the capacitor is faulty.

The method above indicates a presumably good capacitor, but does not verify its microfarad rating as would be necessary when troubleshooting a capacitor whose MF rating has dropped causing a low AC voltage output. In such cases, the capacitor's rating *MUST* be verified accurately.

**⚠ WARNING:** Capacitors must be discharged before handling as they store electricity and can pack a potentially lethal charge even when disconnected from their power source.

DISCHARGING  
THE CAPACITOR

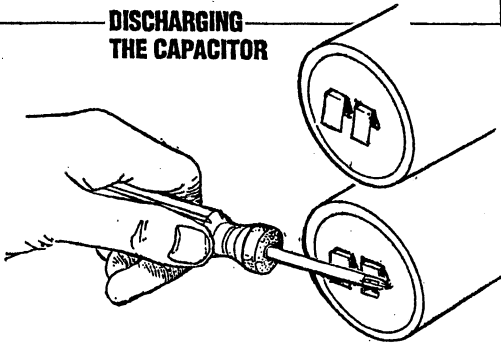

## TESTING THE CAPACITOR(S)

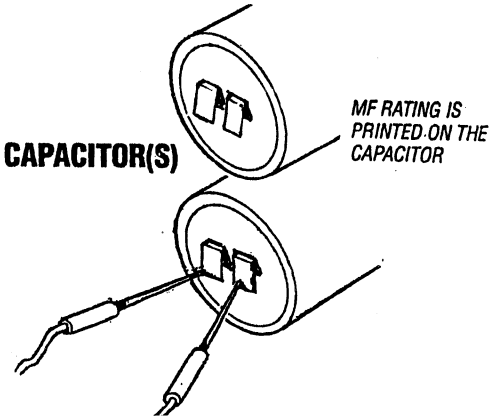

## CAPACITOR RATINGS AND PART NUMBERS

25MFD	Pn. #046875
31.5MFD	Pn. #046978
35MFD	Pn. #046875
40MFD	Pn. #054730
18MFD	Pn. #039556
45MFD	Pn. #046801

**NOTE:** When changing a capacitor due to a capacitor failure, reference the capacitor rating as printed on the body of the capacitor and order the correct replacement. Installing a capacitor of a higher MFD-rating will result in high AC output voltage and installing a capacitor of a lower MFD rating will result in low AC output voltage.

# BC GENERATOR COMPONENTS

## COLISEUM MODEL

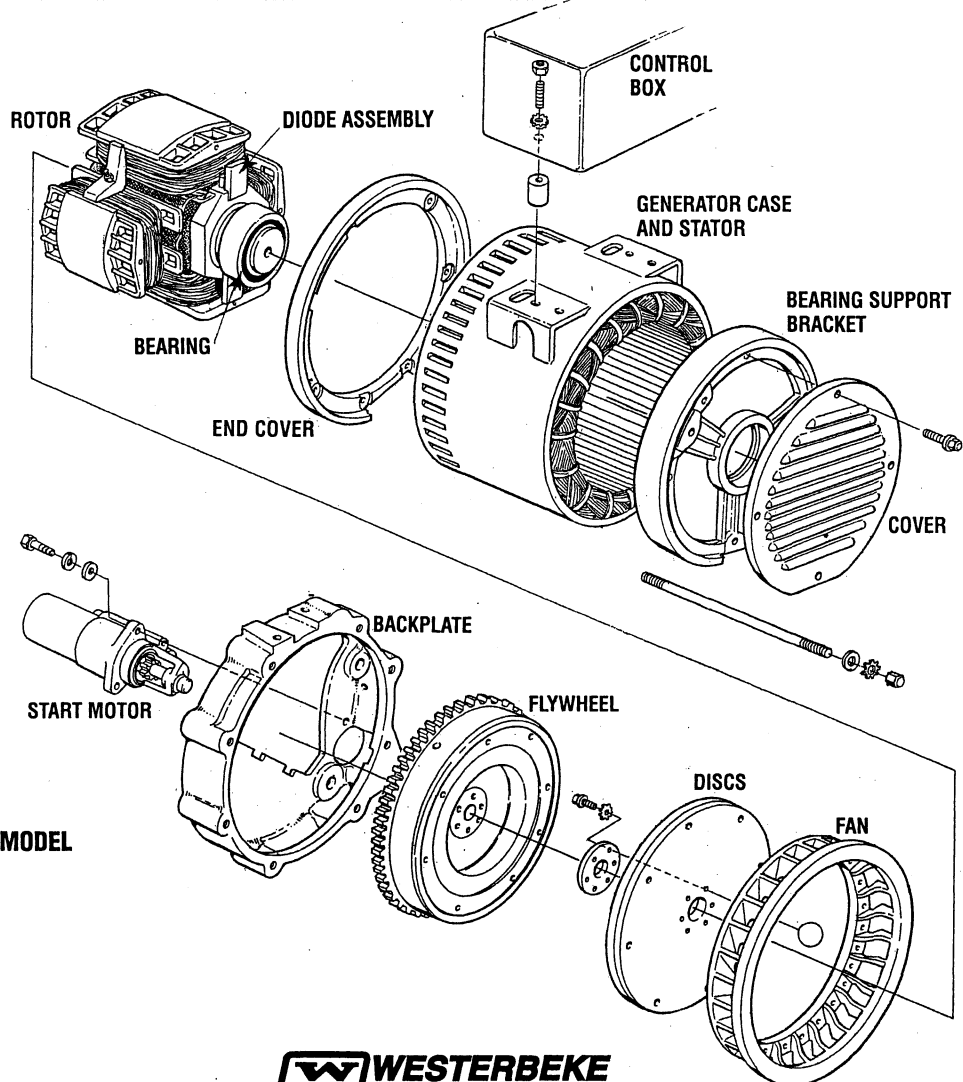
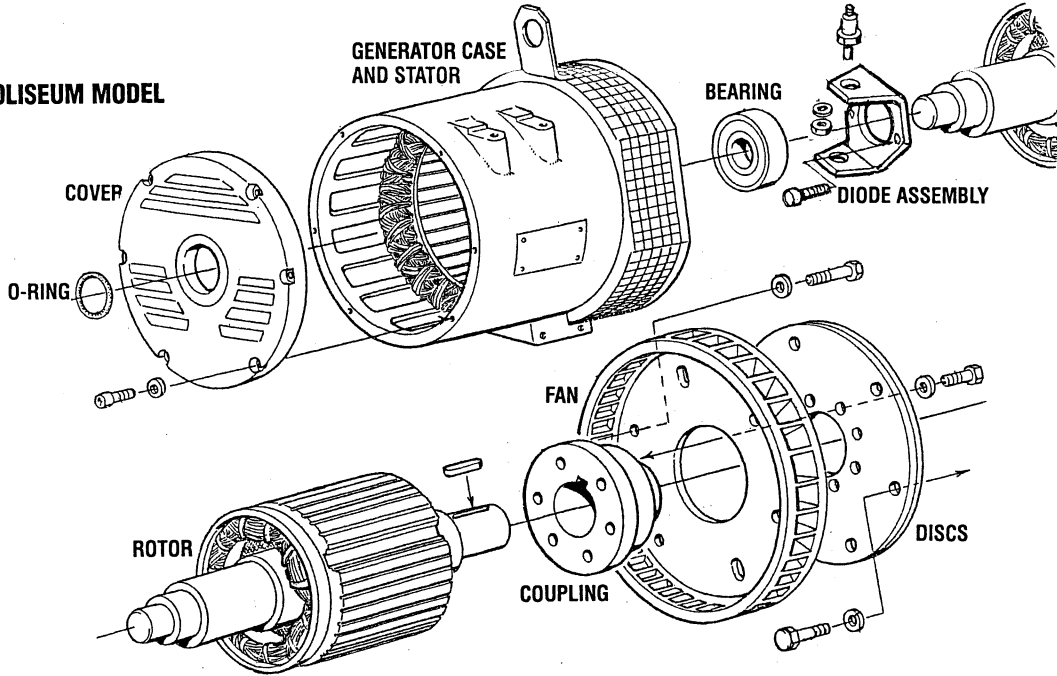

## MECC ALTE MODEL

# GENERATOR WIRING DIAGRAM #46876

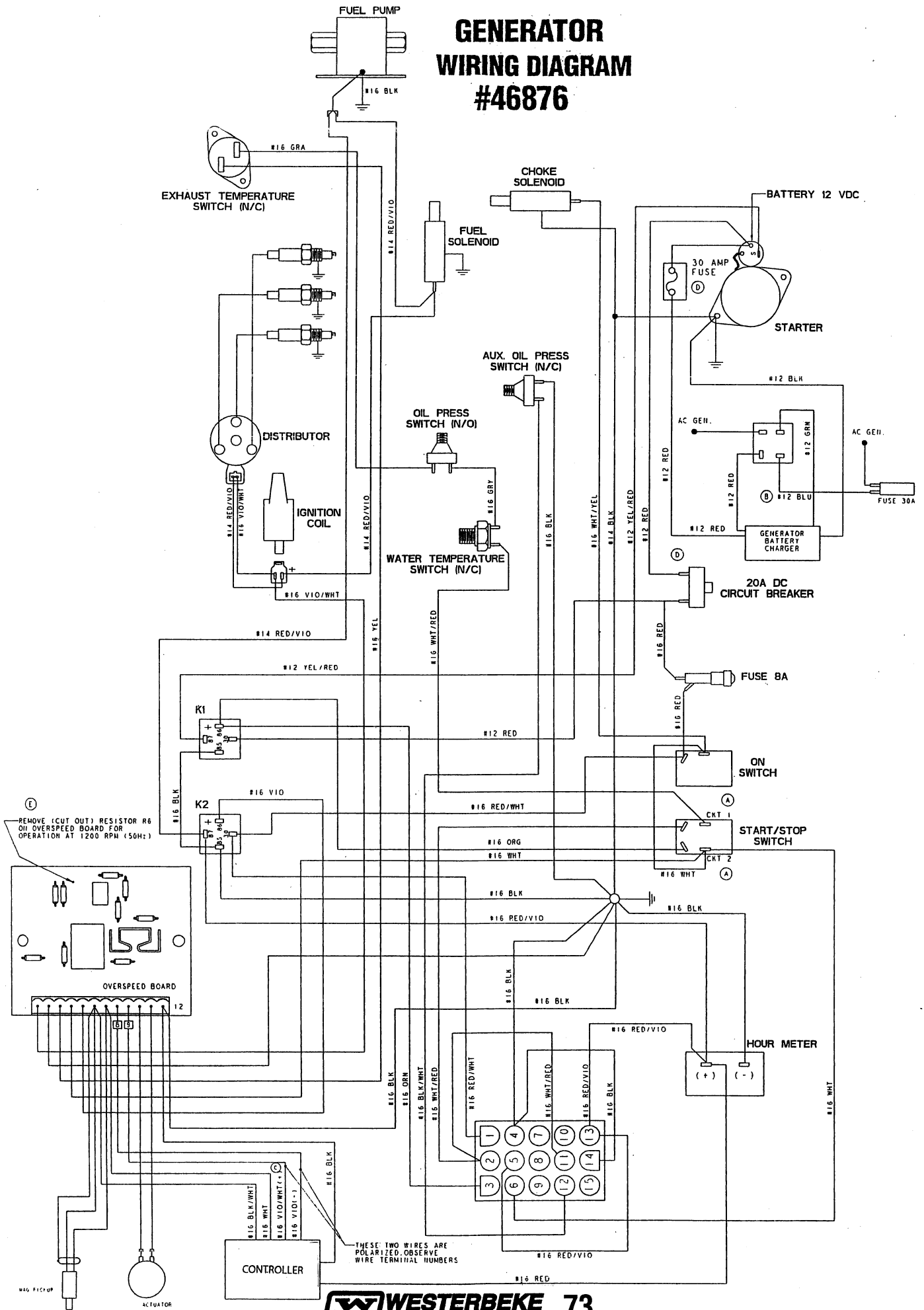



# SPECIAL TOOLS - GENERATOR

## FIELD FABRICATED TOOLS

These drawings provide a means by which simple tools can be made to assist in the removal of the generator end from the engine and in the replacement of the generator end on the engine. A local machine shop should be able to fabricate these tools at a modest price, but first check with your local WESTERBEKE dealer to see if these tools are on hand for loan.

### Housing Puller Tool

This tool allows the bearing in the generator housing to be gently pushed straight off the housing without any twisting. If a nut of the same specifications as that of the tapped hole in the pilot tool were to be welded on the end of the eye bolt, this tool would be able to pull the bearing back into place without any twisting. Please refer to these drawings before the generator end is removed.

#### HOUSING PULLER TOOL (FIELD FABRICATED)

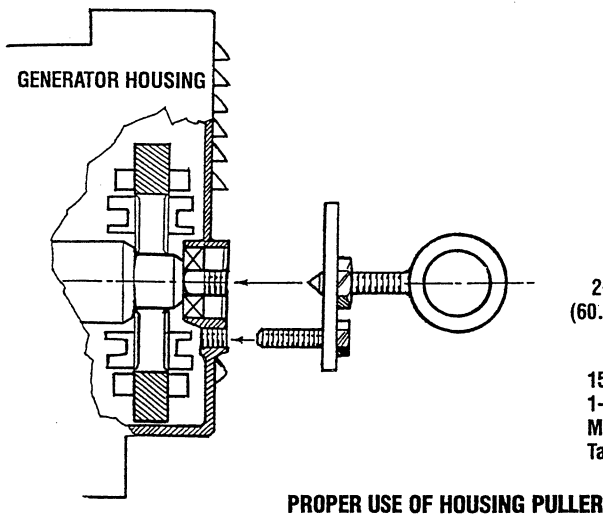
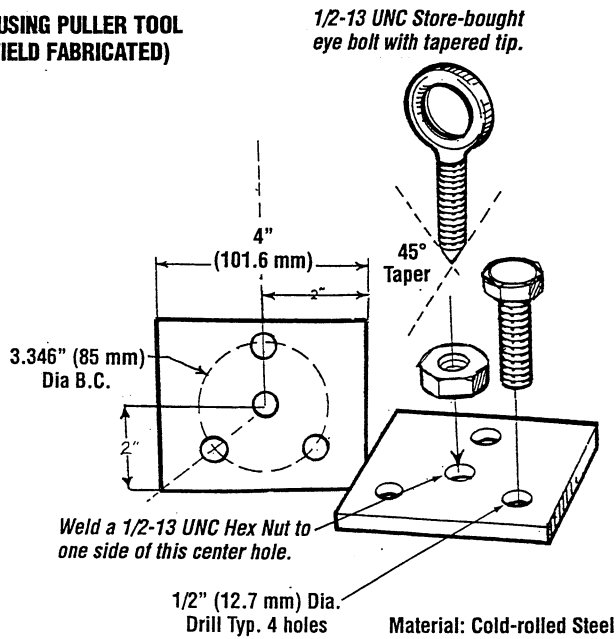

### Lifting Eye Tool

This tool allows a mechanic to safely remove the generator end from the engine by attaching this Generator End Lifting Eye to the four screw holes located under the control panel. To use this Lifting Eye, remove the generator's control panel and screw the Lifting Eye to the generator end.

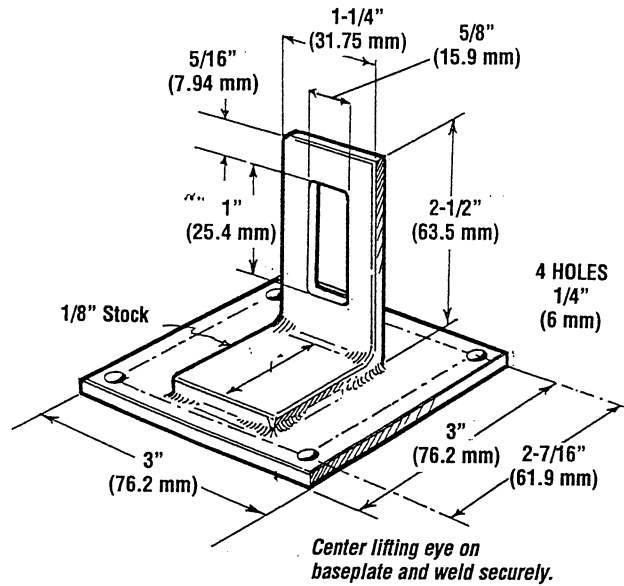

### Disk Alignment Tool

This tool allows a mechanic to safely remove and install the generator drive disks by aligning the disks with the Drive Plate Guide Pin. The Pin screws into the flywheel and acts as a guide. Also the pin helps to support some of the rotor and the drive plate's weight while removing or replacing these parts.

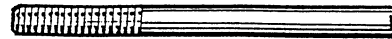

Material: One M8 bolt with the hex head machined off and a screwdriver slot cut in the machined end.

### Pilot Tool

Screwed into the end of the rotor shaft, this tool can be used to pull the stator assembly away from the engine without damaging the stator windings. This tool can be used at reassembly.

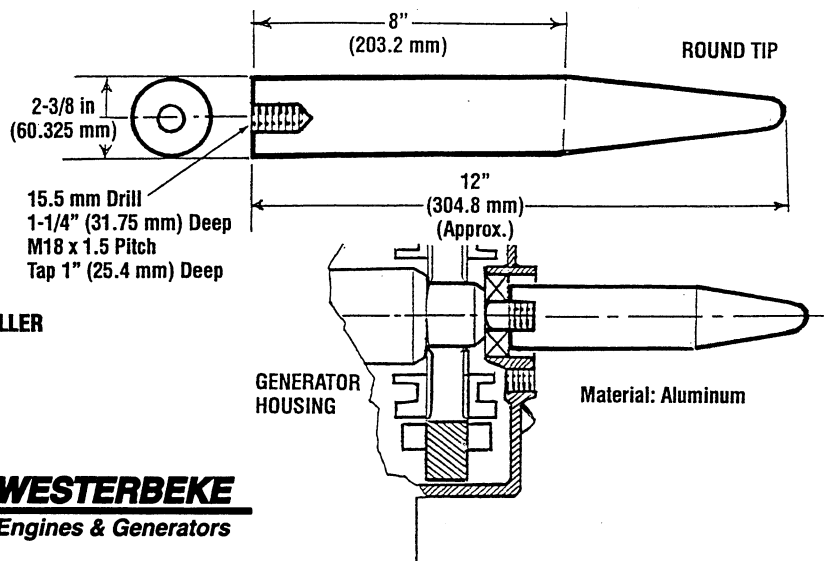

# AC TERMINAL BOARD CONNECTIONS

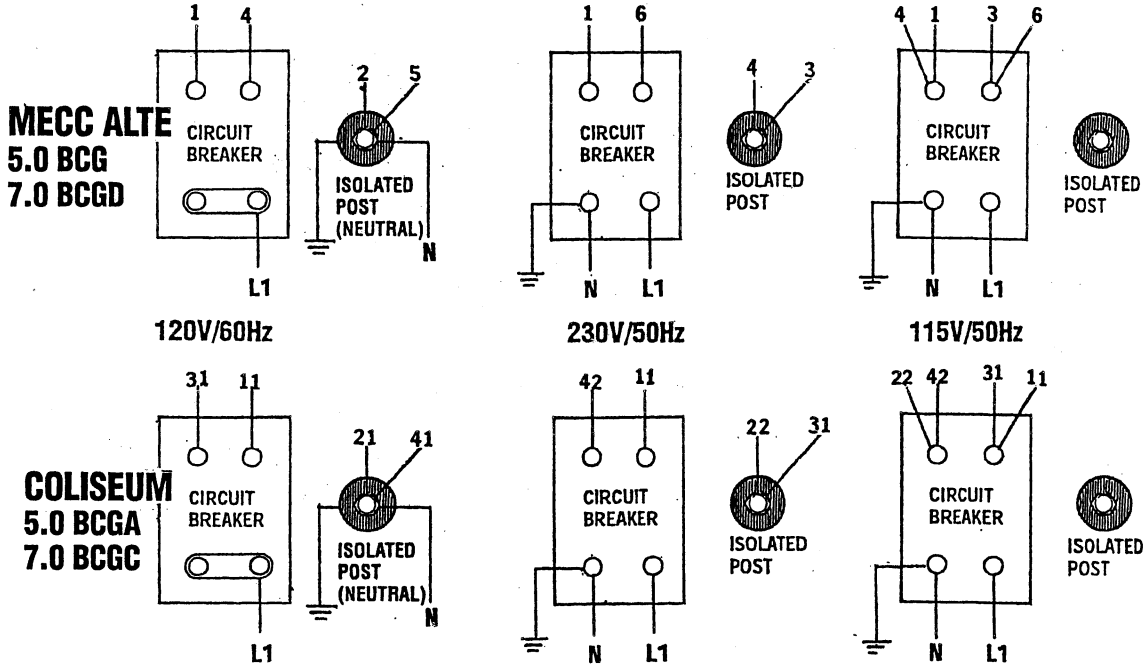

## REMOTE OIL FILTER (OPTIONAL)

PN: 040078

APPLY A THIN COAT OF CLEAN OIL TO THE O-RING WHEN INSTALLING THIS KIT. THREAD THE KIT ON, THEN HAND TIGHTEN AN ADDITIONAL 3/4 TURN AFTER THE O-RING CONTACTS THE BASE.

THE "OUT" CONNECTION HOSE MUST ATTACH TO THE "IN" CONNECTION AT THE REMOTE OIL FILTER.

NOTE: The "in" and "out" markings on the kit (if the hoses are removed for installation) so they can be reconnected correctly.

### INSTALLATION

This popular accessory is used to relocate the engine's oil filter from the engine to a more convenient location such as an engine room bulkhead.

**NOTE:** Refer to *ENGINE OIL CHANGE* in this manual for instructions on removing the oil filter.

To install, simply remove the engine oil filter and thread on WESTERBEKE's remote oil filter kit as shown. Always install this kit with the oil filter facing down as illustrated. Contact your WESTERBEKE dealer for more information.

FASTEN SECURELY TO A BULKHEAD (SCREWS ARE OWNER SUPPLIED)

APPLY A THIN COAT OF CLEAN OIL TO THE FILTER GASKET WHEN INSTALLING. AFTER THE FILTER CONTACTS THE BASE, tighten it firmly by hand

**CAUTION:** It is vital to install the oil lines correctly. If the oil flows in the reverse direction, the by-pass valve in the filter assembly will prevent the oil from reaching the engine, causing an internal engine failure. If there is no oil pressure reading, shutdown immediately and check the hose connections.

# ANGULAR NUT AND BOLT TIGHTENING METHOD

- Carefully wash the nuts and bolts to remove all oil and grease.
- Apply a coat of molybdenum disulfide grease to the threads and setting faces of the nuts and bolts.
- Tighten the nuts and bolts to the specified torque (snug torque) with a torque wrench.

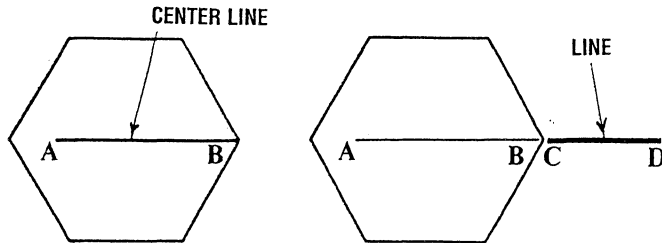

- Draw another line (F-G) on the face of each of the parts to be clamped. This line will be in the direction of the specified angle (Q) across the center (E) of the nut or bolt.
- Use a socket wrench to tighten each nut or bolt to the point where the line (A-B) is aligned with the line (F-G).

Example: Specified Angle and Tightening Rotation

A	30°	1/12 of a turn
B	60°	1/6 of a turn
C	90°	1/4 of a turn
D	180°	1/2 of a turn
E	360°	One full turn

- Draw a line (A-B) across the center of each bolt.
- Draw another line (C-D) on the face of each of the parts to be clamped. This line should be an extension of the line (A-B).

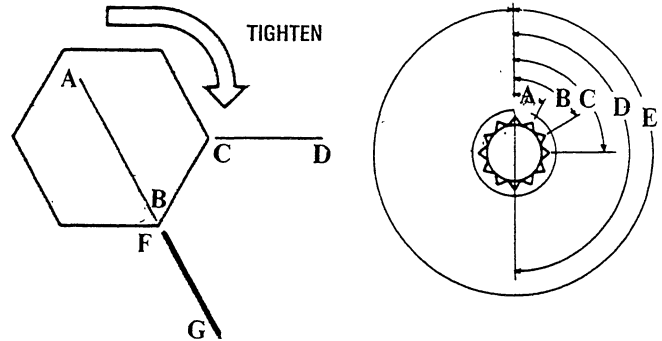
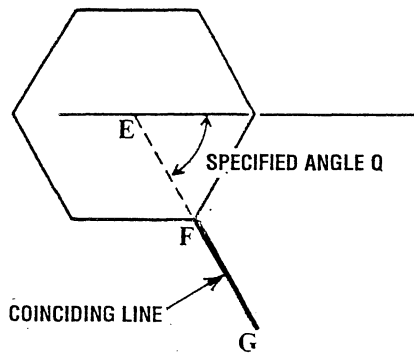

# SHORE POWER TRANSFER SWITCH

## SINGLE LINE 120 VOLT SYSTEM

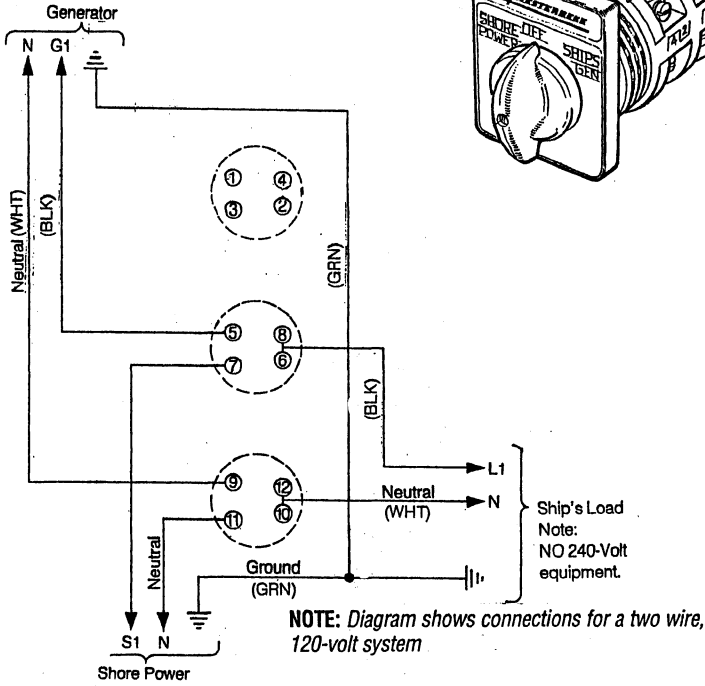

If the installer connects shore power to the vessel's AC circuit, this must be done by means of the Shore Power Transfer Switch. Set the transfer switch shown in the diagrams to the OFF position. This switch prevents simultaneous connection of shore power to generator output.

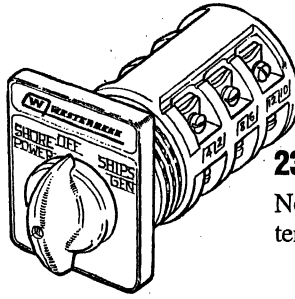

**NOTE:** Ship to shore switches are available at your WESTERBEKE dealer.

## 230 VOLT/50 HERTZ TWO WIRE CONFIGURATION

Notice the repositioning of the white wire ground load on the terminal block to the generator case.

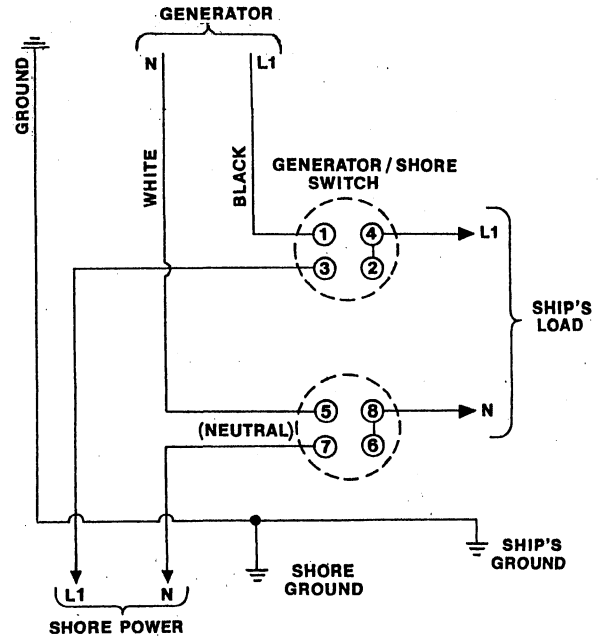

## Switching Shore Power to Generator Power

**CAUTION:** Heavy motor loads should be shut off before switching shore power to generator power or vice-versa because voltage surges induced by switching with heavy AC loads on the vessel being operated may cause damage to the exciter circuit components in the generator.

**CAUTION:** Damage to the generator can result if utility shore power and generator output are connected at the same time. This type of generator damage is not covered under the warranty; it is the installer's responsibility to make sure all AC connections are correct.

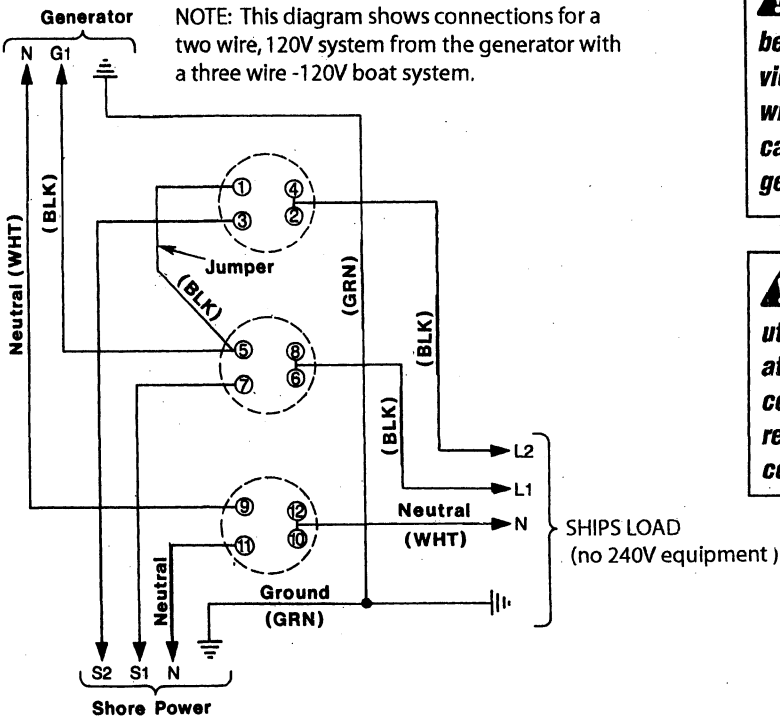

# STANDARD AND METRIC CONVERSION DATA

## LENGTH-DISTANCE

Inches (in) x 25.4 = Millimeters (mm) x .0394 = Inches  
Feet (ft) x .305 = Meters (m) x 3.281 = Feet  
Miles x 1.609 = Kilometers (km) x .0621 = Miles

## VOLUME

Cubic Inches (in<sup>3</sup>) x 16.387 = Cubic Centimeters x .061 = in<sup>3</sup>  
Imperial Pints (IMP pt) x .568 = Liters (L) x 1.76 = IMP pt  
Imperial Quarts (IMP qt) x 1.137 = Liters (L) x .88 = IMP qt  
Imperial Gallons (IMP gal) x 4.546 = Liters (L) x .22 = IMP gal  
Imperial Quarts (IMP qt) x 1.201 = US Quarts (US qt) x .833 = IMP qt  
Imperial Gallons (IMP gal) x 1.201 = US Gallons (US gal) x .833 = IMP gal  
Fluid Ounces x 29.573 = Milliliters x .034 = Ounces  
US Pints (US pt) x .473 = Liters(L) x 2.113 = Pints  
US Quarts (US qt) x .946 = Liters (L) x 1.057 = Quarts  
US Gallons (US gal) x 3.785 = Liters (L) x .264 = Gallons

## MASS-WEIGHT

Ounces (oz) x 28.35 = Grams (g) x .035 = Ounces  
Pounds (lb) x .454 = Kilograms (kg) x 2.205 = Pounds

## PRESSURE

Pounds Per Sq In (psi) x 6.895 = Kilopascals (kPa) x .145 = psi  
Inches of Mercury (Hg) x .4912 = psi x 2.036 = Hg  
Inches of Mercury (Hg) x 3.377 = Kilopascals (kPa) x .2961 = Hg  
Inches of Water (H<sub>2</sub>O) x .07355 = Inches of Mercury x 13.783 = H<sub>2</sub>O  
Inches of Water (H<sub>2</sub>O) x .03613 = psi x 27.684 = H<sub>2</sub>O  
Inches of Water (H<sub>2</sub>O) x .248 = Kilopascals (kPa) x 4.026 = H<sub>2</sub>O

## TORQUE

Pounds-Force Inches (in-lb) x .113 = Newton Meters (Nm) x 8.85 = in-lb  
Pounds-Force Feet (ft-lb) x 1.356 = Newton Meters (Nm) x .738 = ft-lb

## VELOCITY

Miles Per Hour (MPH) x 1.609 = Kilometers Per Hour (KPH) x .621 = MPH

## POWER

Horsepower (Hp) x .745 = Kilowatts (Kw) x 1.34 = MPH

## FUEL CONSUMPTION

Miles Per Hour IMP (MPG) x .354 = Kilometers Per Liter (Km/L)  
Kilometers Per Liter (Km/L) x 2.352 = IMP MPG  
Miles Per Gallons US (MPG) x .425 = Kilometers Per Liter (Km/L)  
Kilometers Per Liter (Km/L) x 2.352 = US MPG

## TEMPERATURE

Degree Fahrenheit (°F) = (°C X 1.8) + 32  
Degree Celsius (°C) = (°F - 32) x .56

# DECIMAL TO METRIC EQUIVALENT CHART

Fractions of an inch	Decimal (in.)	Metric (mm)	Fractions of an inch	Decimal (in.)	Metric (mm)
1/64	0.015625	0.39688	33/64	0.515625	13.09687
1/32	0.03125	0.79375	17/32	0.53125	13.49375
3/64	0.046875	1.19062	35/64	0.546875	13.89062
1/16	0.0625	1.58750	9/16	0.5625	14.28750
5/64	0.078125	1.98437	37/64	0.578125	14.68437
3/32	0.09375	2.38125	19/32	0.59375	15.08125
7/64	0.109375	2.77812	39/64	0.609375	15.47812
1/8	0.125	3.175	5/8	0.625	15.87500
9/64	0.140625	3.57187	41/64	0.640625	16.27187
5/32	0.15625	3.96875	21/32	0.65625	16.66875
11/64	0.171875	4.36562	43/64	0.671875	17.06562
3/16	0.1875	4.76250	11/16	0.6875	17.46250
13/64	0.203125	5.15937	45/64	0.703125	17.85937
7/32	0.21875	5.55625	23/32	0.71875	18.25625
15/64	0.234375	5.95312	47/64	0.734375	18.65312
1/4	0.250	6.35000	3/4	0.750	19.05000
17/64	0.265625	6.74687	49/64	0.765625	19.44687
9/32	0.28125	7.14375	25/32	0.78125	19.84375
19/64	0.296875	7.54062	51/64	0.796875	20.24062
5/16	0.3125	7.93750	13/16	0.8125	20.63750
21/64	0.328125	8.33437	53/64	0.828125	21.03437
11/32	0.34375	8.73125	27/32	0.84375	21.43125
23/64	0.359375	9.12812	55/64	0.859375	21.82812
3/8	0.375	9.52500	7/8	0.875	22.22500
25/64	0.390625	9.92187	57/64	0.890625	22.62187
13/32	0.40625	10.31875	29/32	0.90625	23.01875
27/64	0.421875	10.71562	59/64	0.921875	23.41562
7/16	0.4375	11.11250	15/16	0.9375	23.81250
29/64	0.453125	11.50937	61/64	0.953125	24.20937
15/32	0.46875	11.90625	31/32	0.96875	24.60625
31/64	0.484375	12.30312	63/64	0.984375	25.00312
1/2	0.500	12.70000	1	1.00	25.40000

# ENGLISH TO METRIC CONVERSION CHART

<b>Multiply Temperature</b>	<b>By</b>	<b>To get equivalent number of:</b>
Degree Fahrenheit (°F)	(°F-32) ÷ 1.8	Degree Celsius (°C)
<b>Multiply Acceleration</b>	<b>By</b>	<b>To get equivalent number of:</b>
Foot/second <sup>2</sup> (ft./sec <sup>2</sup> )	0.3048	Meter/second <sup>2</sup> (m/s <sup>2</sup> )
Inch/second <sup>2</sup> (in./sec <sup>2</sup> )	0.0254	Meter/second <sup>2</sup> (m/s <sup>2</sup> )
<b>Multiply Torque</b>	<b>By</b>	<b>To get equivalent number of:</b>
Pound-inch (lb-in.)	0.11298	Newton-meters (N-m)
Pound-foot (lb-ft)	1.3558	Newton-meters (N-m)
<b>Multiply Power</b>	<b>By</b>	<b>To get equivalent number of:</b>
Horsepower (hp)	0.746	Kilowatts (kW)
<b>Multiply Pressure or Stress</b>	<b>By</b>	<b>To get equivalent number of:</b>
Inches of water (in. H <sub>2</sub> O)	0.2491	Kilopascals (kPa)
Pounds/square in. (lb/in. <sup>2</sup> )	6.895	Kilopascals (kPa)
<b>Multiply Energy or Work</b>	<b>By</b>	<b>To get equivalent number of:</b>
British Thermal Unit (Btu)	1055	Joules (J)
Foot-pound (ft-lb)	1.3558	Joules (J)
kilowatt-hour (kW-hr)	3,600,000. or 3.6 x 10 <sup>6</sup>	Joules (J = one W/s)
<b>Multiply Light</b>	<b>By</b>	<b>To get equivalent number of:</b>
Foot candle (fc)	1.0764	Lumens/meter <sup>2</sup> (lm/m <sup>2</sup> )
<b>Multiply Fuel Performance</b>	<b>By</b>	<b>To get equivalent number of:</b>
Miles/gal (mile/gal)	0.4251	Kilometers/liter (km/L)
Gallons/mile (gal/mile)	2.3527	Liter/kilometer (L/km)
<b>Multiply Velocity</b>	<b>By</b>	<b>To get equivalent number of:</b>
Miles/hour (mile/hr)	1.6093	Kilometers/hour (km/hr)

<b>Multiply Length</b>	<b>By</b>	<b>To get equivalent number of:</b>
Inch (in.)	25.4	Millimeters (mm)
Foot (ft)	0.3048	Meters (m)
Yard (yd)	0.9144	Meters (m)
Mile (mile)	1.609	Kilometers (km)
<b>Multiply Area</b>	<b>By</b>	<b>To get equivalent number of:</b>
Inch <sup>2</sup> (in. <sup>2</sup> )	6452	Millimeters <sup>2</sup> (mm <sup>2</sup> )
Inch <sup>2</sup> (in. <sup>2</sup> )	6.45	Centimeters <sup>2</sup> (cm <sup>2</sup> )
Foot <sup>2</sup> (ft <sup>2</sup> )	0.0929	Meters <sup>2</sup> (m <sup>2</sup> )
Yard <sup>2</sup> (yd <sup>2</sup> )	0.8361	Meters <sup>2</sup> (m <sup>2</sup> )
<b>Multiply Volume</b>	<b>By</b>	<b>To get equivalent number of:</b>
Inch <sup>3</sup> (in. <sup>3</sup> )	16387	Millimeters <sup>3</sup> (mm <sup>3</sup> )
Inch <sup>3</sup> (in. <sup>3</sup> )	16.387	Centimeters <sup>3</sup> (cm <sup>3</sup> )
Inch <sup>3</sup> (in. <sup>3</sup> )	0.0164	Liters (L)
Quart (qt)	0.9464	Liters (L)
Gallon (gal)	3.785	Liters (L)
Yard <sup>3</sup> (yd <sup>3</sup> )	0.7646	Meters <sup>3</sup> (m <sup>3</sup> )
<b>Multiply Mass</b>	<b>By</b>	<b>To get equivalent number of:</b>
Pound (lb)	0.4536	Kilograms (kg)
Ton (ton)	907.18	Kilograms (kg)
Ton (ton)	0.907	Tonne (t)
<b>Multiply Force</b>	<b>By</b>	<b>To get equivalent number of:</b>
Kilogram (kg)	9.807	Newtons (N)
Ounce (oz)	0.2780	Newtons (N)
Pound (lb)	4.448	Newtons (N)

# INDEX

Bridge Rectifier	58	Oil Pump	24
BCG/BCGA Specifications	60	Oil Pump, Front Case, and Oil Pan	24
BCGC/BCGD Specifications	59	Oil Seal	29
Angular Nut and Bolt Method	76	Parts identification	2
Assembly - Engine	12	Piston Clearance	31
Battery Charge Controller	57	Pistons	19
BC Generators - Description	61	Pump - Coolant	36
Bearings	28	Raw Water Pump	37
Camshaft	28	Relays - Testing	47
Camshaft and Rocker Arms	17	Remote Panel Wiring Schematic	46
Capacitors Testing	69	Rocker Arms	17
Carburetor	38	Safety Instructions	1
Choke Solenoid	57	Schematic Windings ( <i>Coliseum</i> )	65
Compression Test	55	Service Standards and Limits	32
Connecting Rods	19	Shore Power Transfer Switch	77
Control Box Components	67	Spark Plugs	56
Coolant Circulation Pump	36	Special Tools - Engine	34
Counterbalance Shaft	24	Special Tools - Generator	74
Crankshaft, Bearing, and Oil Seal	29	Specifications - 5.0 BCG/BCGA	60
Cylinder Block Inspection	31	Specifications - 7.0 BCGC/BCGD	59
Cylinder Head and Valves	13	Standards and Limits	32
Decimal/Metric Chart	79	Starter Motor	40
Diodes - Testing	67	Torquing the Cylinder Head Bolts	55
Distributor	39	Terminal Board Connections	75
Electronic Governor	49	Testing Diodes	67
Engine Adjustments	54	Testing Engine Compression	55
Engine Assembly	12	Testing for Overhaul	3
Engine Assembly - General Data	6,7	Testing Oil Pressure	55
Engine Troubleshooting	4	Testing Relays	47
Exciter Windings Testing	70	Testing Shutdown Switches	47
Exciting the Generator	68	Testing the BC Rotor ( <i>Coliseum</i> )	66
Exhaust Manifold	35	Testing the BC Rotor ( <i>Mecc Alte</i> )	64
Front Case	24	Testing the Igniter	48
Generators - Maintenance	61	Testing Windings	70
Generator Components	72	Timing Belt	8
Generator Information	61	Torques - Hardware	33a
Generator Troubleshooting	69	Troubleshooting - Engine/Generator	4
Generator Wiring Diagram	44	Troubleshooting - Generator	69
Generator Wiring Schematic	45	Troubleshooting Chart ( <i>Coliseum</i> )	65
Governor Troubleshooting	54	Troubleshooting Chart Governor	54
Hardware Torques	33a	Troubleshooting Chart ( <i>Mecc Alte</i> )	63
Heat Exchanger	35	Troubleshooting Governor	51
High Tension Cords	55	Valve Clearance	55
Ignition Wires	55	Valves	13
Ignition Timing	56	Winding Schematic ( <i>Coliseum</i> )	65
Igniter Testing	48	Wiring Diagram	73
Magnetic Pick-Up	53	Wiring Diagram - Generator	44
Maintenance - Generator	61	Wiring Schematic - Generator	45
Manifold - Exhaust	35	Wiring Schematic - Remote Panel	46
Metric Conversion Chart	80	Wiring Schematic ( <i>Mecc Alte</i> )	63
Metric/Standard Formulas	78	Wiring Schematic - Control Panel	50







1124-8/2014